

Product Not Recommended for New Designs

RocketIO™ Transceiver User Guide

UG024 (v3.0) February 22, 2007



Product Not Recommended for New Designs



"Xilinx" and the Xilinx logo shown above are registered trademarks of Xilinx, Inc. Any rights not expressly granted herein are reserved. CoolRunner, RocketChips, Rocket IP, Spartan, StateBENCH, StateCAD, Virtex, XACT, XC2064, XC3090, XC4005, and XC5210 are registered trademarks of Xilinx, Inc.



The shadow X shown above is a trademark of Xilinx, Inc.

ACE Controller, ACE Flash, A.K.A. Speed, Alliance Series, AllianceCORE, Bencher, ChipScope, Configurable Logic Cell, CORE Generator, CoreLINX, Dual Block, EZTag, Fast CLK, Fast CONNECT, Fast FLASH, FastMap, Fast Zero Power, Foundation, Gigabit Speeds...and Beyond!, HardWire, HDL Bencher, IRL, J Drive, JBits, LCA, LogiBLOX, Logic Cell, LogiCORE, LogicProfessor, MicroBlaze, MicroVia, MultiLINX, NanoBlaze, PicoBlaze, PLUSASM, PowerGuide, PowerMaze, QPro, Real-PCI, RocketIO, SelectIO, SelectRAM, SelectRAM+, Silicon Xpresso, Smartguide, Smart-IP, SmartSearch, SMARTswitch, System ACE, Testbench In A Minute, TrueMap, UIM, VectorMaze, VersaBlock, VersaRing, Virtex-II Pro, Virtex-II EasyPath, Wave Table, WebFITTER, WebPACK, WebPOWERED, XABEL, XACT-Floorplanner, XACT-Performance, XACTstep Advanced, XACTstep Foundry, XAM, XAPP, X-BLOX +, XC designated products, XChecker, XDM, XEPLD, Xilinx Foundation Series, Xilinx XDTV, Xinfo, XSI, XtremeDSP and ZERO+ are trademarks of Xilinx, Inc.

The Programmable Logic Company is a service mark of Xilinx, Inc.

All other trademarks are the property of their respective owners.

Xilinx, Inc. does not assume any liability arising out of the application or use of any product described or shown herein; nor does it convey any license under its patents, copyrights, or maskwork rights or any rights of others. Xilinx, Inc. reserves the right to make changes, at any time, in order to improve reliability, function or design and to supply the best product possible. Xilinx, Inc. will not assume responsibility for the use of any circuitry described herein other than circuitry entirely embodied in its products. Xilinx provides any design, code, or information shown or described herein "as is." By providing the design, code, or information as one possible implementation of a feature, application, or standard, Xilinx makes no representation that such implementation is free from any claims of infringement. You are responsible for obtaining any rights you may require for your implementation. Xilinx expressly disclaims any warranty whatsoever with respect to the adequacy of any such implementation, including but not limited to any warranties or representations that the implementation is free from claims of infringement, as well as any implied warranties of merchantability or fitness for a particular purpose. Xilinx, Inc. devices and products are protected under U.S. Patents. Other U.S. and foreign patents pending. Xilinx, Inc. does not represent that devices shown or products described herein are free from patent infringement or from any other third party right. Xilinx, Inc. assumes no obligation to correct any errors contained herein or to advise any user of this text of any correction if such be made. Xilinx, Inc. will not assume any liability for the accuracy or correctness of any engineering or software support or assistance provided to a user.

Xilinx products are not intended for use in life support appliances, devices, or systems. Use of a Xilinx product in such applications without the written consent of the appropriate Xilinx officer is prohibited.

The contents of this manual are owned and copyrighted by Xilinx. Copyright 2001–2007 Xilinx, Inc. All Rights Reserved. Except as stated herein, none of the material may be copied, reproduced, distributed, republished, downloaded, displayed, posted, or transmitted in any form or by any means including, but not limited to, electronic, mechanical, photocopying, recording, or otherwise, without the prior written consent of Xilinx. Any unauthorized use of any material contained in this manual may violate copyright laws, trademark laws, the laws of privacy and publicity, and communications regulations and statutes.

Product Not Recommended for New Designs

RocketIO™ Transceiver User Guide UG024 (v3.0) February 22, 2007

The following table shows the revision history for this document.

Date	Version	Revision
11/20/01	1.0	<ul style="list-style-type: none">Initial Xilinx release.
01/23/02	1.1	<ul style="list-style-type: none">Updated for typographical and other errors found during review.
02/25/02	1.2	<ul style="list-style-type: none">Part of Virtex-II Pro™ Developer's Kit (March 2002 Release)
07/11/02	1.3	<ul style="list-style-type: none">Updated "PCB Design Requirements". Added Appendix A, "RocketIO Transceiver Timing Model." Changed Cell Models to Appendix B.
09/27/02	1.4	<ul style="list-style-type: none">Added additional IMPORTANT NOTE regarding ISE revisions at the beginning of Chapter 1Added material in section "CRC (Cyclic Redundancy Check)."Added section "Other Important Design Notes."New pre-emphasis eye diagrams in section "Pre-emphasis Techniques."Numerous parameter additions previously shown as "TBD" in "MGT Package Pins."
10/16/02	1.5	<ul style="list-style-type: none">Corrected pinouts for FF1152 package, device column 2VP20/30, LOC Constraints rows GT_X0_Y0 and GT_X0_Y1.Corrected section "CRC Latency" and Table 2-20 to express latency in terms of TXUSRCLK and RXUSRCLK cycles.Corrected sequence of packet elements in Figure 2-30.
11/20/02	1.6	<ul style="list-style-type: none">Table 1-2: Added support for XAUI Fibre Channel.Corrected max PCB drive distance to 40 inches.Reorganized content sequence in Chapter 2, "Digital Design Considerations."Table 1-5: Additional information in RXCOMMADET definition.Code corrections in VHDL Clock templates."Data Path Latency" section expanded and reformatted.Corrections in clocking scheme drawings. Addition of drawings showing clocking schemes without using DCM.Table B-1: Corrections in Valid Data Characters.Table 3-4: Data added.Corrections made to power regulator schematic, Figure 3-7.Table 2-23: Data added/corrected.
12/12/02	1.6.1	<ul style="list-style-type: none">Added clarifying text regarding trace length vs. width.
03/25/03	2.0	<ul style="list-style-type: none">Reorganized existing contentAdded new contentAdded Appendix C, "Related Online Documents"Added "Index"

Product Not Recommended for New Designs

Date	Version	Revision
06/12/03	2.1	<ul style="list-style-type: none"> • Table 1-2: Added qualifying footnote to XAUI 10GFC. • Table 1-5: Corrected definition of RXRECCLK. • Section “RocketIO Transceiver Instantiations” in Chapter 1: added text briefly explaining what the Instantiation Wizard does. • Table 2-14: Changed numerics from exact values to rounded-off approximations (nearest 5,000), and added footnote calling attention to this. • Section “Clocking” in Chapter 2: added text recommending use of an IBUFGDS for reference clock input to FPGA fabric. • Section “RXRECCLK” in Chapter 2: Deleted references to SERDES_10B attribute and to divide-by-10. (RXRECCLK is always 1/20th the data rate.). • Section “CRC_FORMAT” in Chapter 2: Corrected minimum data length for USER_MODE to “greater than 20”. • Table 3-5: Clarified the significance of the V_{TTX}/V_{TRX} voltages shown in this table. • Section “AC and DC Coupling” in Chapter 3: Explanatory material added regarding V_{TRX}/V_{TTX} settings when AC or DC coupling is used. • Table 4-1: Corrected pinouts for FG256 and FG456. • Table 4-3: Corrected pinouts for FF1517 (XC2VP70).
11/07/03	2.2	<ul style="list-style-type: none"> • Section “Clock Signals” in Chapter 2: Added material that states: <ul style="list-style-type: none"> ◆ the reference clock must be provided at all times. ◆ any added jitter on the reference clock will be reflected on the RX/TX I/O. • Figure 2-3: Added a BUFG after the IBUFGDS reference clock buffer. • Section “RX_BUFFER_USE” in Chapter 2: Corrected erroneous “USRCLK2” to “RXUSRCLK/RXUSRCLK2”. • Table 2-20: Added footnotes qualifying the maximum receive-side latency parameters given in the table. • Section “FIBRE_CHAN” in Chapter 2: Added specification for minimum data length (24 bytes not including CRC placeholder). • Section “ETHERNET” in Chapter 2: Added note indicating that Gigabit Ethernet 802.3 frame specifications must be adhered to. • Table 2-23: Corrected “External” to “Internal” loopback. Improved explanation of Parallel Mode loopback. • Added Figure 2-28, “Serial and Parallel Loopback Logic.” • Section “Clock and Data Recovery” in Chapter 3: Corrected text to make clear that RXRECCLK is always 1/20th the incoming data rate, and that CDR requires a minimum number of transitions to achieve and maintain a lock on the received data. • Section “Voltage Regulation” in Chapter 3: Added material defining voltage regulator requirements when a device other than the LT1963 is used. • Section “AC and DC Coupling” in Chapter 3: Added footnote to Table 3-8 clarifying V_{TRX}/V_{TTX} voltage compliance. • Figure 3-17 and section “Epson EG-2121CA 2.5V (LVPECL Outputs)” in Chapter 3: Added material specifying the optional use of an LVPECL buffer as an alternative to the LVDS buffer previously specified. • Table 4-2: Added pinouts for FG676 package, XC2VP20 and XC2VP30. • Table A-5: Added BREFCLK parameters $T_{BREFPWH}$ and $T_{BREFPWL}$. • Section “Application Notes” in Appendix C: Included new Xilinx Application Notes XAPP648, XAPP669, and XAPP670. • Various non-technical edits and corrections.

Product Not Recommended for New Designs

Date	Version	Revision
02/24/04	2.3	<ul style="list-style-type: none"> • Table 2-3, page 41: Added FG676 row to BREFCLK Pin Numbers. • Figure 2-4, page 47: Added note above Figure 2-4 stating, “These local MGT clock input inverters, shown and noted in Figure 2-4, are not included in the FOUR_BYTE_CLK templates. • Section “RXRECCLK” in Chapter 2: Added paragraph to section explaining how RXRECCLK changes monotonically and how the recovered bit clock is derived. • Section “Data Path Latency” in Chapter 2: Revised first sentence to read: “With the many configurations of the MGT, both the transmit and receive data path latencies vary.” • Section “RXBUFSTATUS” in Chapter 2: Revised the description of RXBUFSTATUS. • Figure 3-1, page 103: Replaced old Figure 3-1, page 101, with new Figure 3-1 showing “Differential Amplifier.” • Figure 3-6, page 107: Added new Figure 3-6, page 105, showing “MGT Receiver.” • Table 3-4, page 108: Added text to CDR Parameters (TLOCK parameter in Conditions column) and edited Note 3. • Section “Voltage Regulation” in Chapter 3: Added Linear Technology part numbers (LT1963A, LT1964). • Section “Passive Filtering” in Chapter 3: Added new cap rules for RocketIO transceiver. • Figure 3-8, page 111: Replaced old Figure 3-8 with new figure showing “Power Filtering Network on Devices with Internal and External Capacitors.” • Table 3-7, page 112: Added Device and Package combinations table. • Figure 3-9, page 113: Added new Figure 3-10, page 110, showing “Example Power Filtering PCB Layout for Four MGTs, in Device with Internal Capacitors, Bottom Layer.” Modified the text describing Figure 3-9, page 113. • Figure 3-10, page 114: Replaced old Figure 3-10 with new figure showing “Example Power Filtering PCB Layout for Four MGTs, in Device with External Capacitors, Top Layer.” Removed the text describing old Figure 3-10. • Figure 3-11, page 115: Replaced old Figure 3-11 with new figure showing “Example Power Filtering PCB Layout for Four MGTs, in Device with External Capacitors, Bottom Layer.” Removed the text describing old Figure 3-11. • Table 3-8, page 118: Added V_{TRX} and V_{TTX} voltages for different coupling environments.
05/20/04	2.3.1	<ul style="list-style-type: none"> • Changed the value of TRCLK/RFCLK in Table 3-4.
06/24/04	2.3.2	<ul style="list-style-type: none"> • Modified Figure 2-3.
08/25/04	2.4	<ul style="list-style-type: none"> • Fixed error in Hex value in Table 2-15, page 74. • Add application notes to Appendix C, “Related Online Documents.” • Replaced “Voltage Regulation” section with “Voltage Regulator Selection and Use” in Chapter 3. • Removed all references to the XCVP125 device. • Modified Note 4 in Table 3-5.
12/09/04	2.5	<ul style="list-style-type: none"> • Added PCI Express and new note to Table 1-2. Added sentence to REFCLK definition in Table 1-5. Updated Table 3-5. • Fixed typo in “Epson EG-2121CA 2.5V (LVPECL Outputs),” page 119. • Added XAPP572 to Appendix C, “Related Online Documents” and added references to XAPP572 in Table 1-6 (under SERDES_10B description) and “Half-Rate Clocking Scheme,” page 54.

Product Not Recommended for New Designs

Date	Version	Revision
02/22/07	3.0	<ul style="list-style-type: none">• “Example 1a: Two-Byte Clock with DCM,” page 43: Corrected code in TWO_BYTE_CLK definition (VHDL).• “Example 2: Four-Byte Clock,” page 46: Corrected code in DCM instantiation (VHDL).• “RX_LOSS_OF_SYNC_FSM,” page 77: Added note that PLL must be locked for attribute values to be valid.• “CRC Operation,” page 84: Added CRC logic start state on reset.• “Power Conditioning,” page 109: Fixed broken link to Data Sheet DS083.• “Passive Filtering,” page 111: Corrected part number of Murata ferrite bead.• “Pletronics LV1145B (LVDS Outputs),” page 119: Corrected I/O standard name to LVDS_25_DT.• “Powering the RocketIO Transceivers,” page 120: Added section “Pin Connections on the Unused RocketIO Transceivers.”• “The POWERDOWN Port,” page 120: Added that toggling POWERDOWN properly initializes the PMA.• “HSPICE,” page 121 and “Characterization Reports,” page 149: Fixed obsolete links to SPICE Model and Characterization Report web pages.• Figure 2-12: In 8B/10B Data Flow block diagram, moved Comma Detect function from PMA to PCS.• Table 3-4:<ul style="list-style-type: none">◆ Corrected REFCLK/BREFCLK typical rise/fall time from 400 ps to 600 ps.◆ Corrected TLOCK acquisition time from Typ to Max.• Table 3-5: Corrected voltage range in heading to 1.6V–1.8V.• Table B-1: Corrected data characters D18.2, D09.3, D10.3, D18.5, and D18.6.

Table of Contents

Schedule of Figures	13
Schedule of Tables	15
Preface: About This Guide	
RocketIO Features	17
Guide Contents	17
For More Information	18
Additional Resources	18
Conventions	19
Port and Attribute Names.....	19
Typographical.....	19
Online Document.....	20
Chapter 1: RocketIO Transceiver Overview	
Basic Architecture and Capabilities	21
RocketIO Transceiver Instantiations	23
HDL Code Examples	23
List of Available Ports	24
Primitive Attributes	29
Modifiable Primitives	34
Byte Mapping	38
Chapter 2: Digital Design Considerations	
Clocking	39
Clock Signals.....	39
BREFCLK	41
Clock Ratio	42
Digital Clock Manager (DCM) Examples.....	42
Example 1a: Two-Byte Clock with DCM	43
Example 1b: Two-Byte Clock without DCM.....	46
Example 2: Four-Byte Clock	46
Example 3: One-Byte Clock.....	50
Half-Rate Clocking Scheme	54
Multiplexed Clocking Scheme with DCM	55
Multiplexed Clocking Scheme without DCM	55
RXRECCLK.....	56
Clock Dependency.....	56
Data Path Latency	57
Reset/Power Down	57
8B/10B Encoding/Decoding	60
Overview	60
8B/10B Encoder	60

8B/10B Decoder	60
Ports and Attributes	61
TXBPASS8B10B,	
RX_DECODE_USE	61
TXCHARDISPVAL,	
TXCHARDISPMODE	62
TXCHARISK	63
TXRUNDISP	63
TXKERR	63
RXCHARISK,	
RXRUNDISP	63
RXDISPERR	64
RXNOTINTABLE	64
Vitesse Disparity Example	64
Transmitting Vitesse Channel Bonding Sequence	64
Receiving Vitesse Channel Bonding Sequence	65
8B/10B Bypass Serial Output	65
8B/10B Serial Output Format	66
HDL Code Examples: Transceiver Bypassing of 8B/10B Encoding	66
SERDES Alignment	67
Overview	67
Serializer	67
Deserializer	67
Ports and Attributes	67
ALIGN_COMMA_MSB	67
ENPCOMMAALIGN,	
ENMCOMMAALIGN	68
PCOMMA_DETECT,	
MCOMMA_DETECT	70
COMMA_10B_MASK,	
PCOMMA_10B_VALUE,	
MCOMMA_10B_VALUE	70
DEC_PCOMMA_DETECT,	
DEC_MCOMMA_DETECT,	
DEC_VALID_COMMA_ONLY	70
RXREALIGN	70
RXCHARISCOMMA	71
RXCOMMADET	71
Clock Recovery	71
Overview	71
Clock Synthesizer	71
Clock and Data Recovery	72
Clock Correction	72
Ports and Attributes	73
CLK_CORRECT_USE	73
RX_BUFFER_USE	74
CLK_COR_SEQ_*_*	74
CLK_COR_SEQ_LEN	75
CLK_COR_INSERT_IDLE_FLAG,	
CLK_COR_KEEP_IDLE,	
CLK_COR_REPEAT_WAIT	75
Synchronization Logic	76
Overview	76

Ports and Attributes	76
RXCLKCORCNT	76
RX_LOS_INVALID_INCR,	
RX_LOS_THRESHOLD	77
RX_LOSS_OF_SYNC_FSM	77
RXLOSSOFSYNC	77
Channel Bonding (Channel Alignment)	79
Overview	79
Channel Bonding (Alignment) Operation	80
Ports and Attributes	81
CHAN_BOND_MODE	81
ENCHANSYNC	81
CHAN_BOND_ONE_SHOT	81
CHAN_BOND_SEQ_*_* ,	
CHAN_BOND_SEQ_LEN,	
CHAN_BOND_SEQ_2_USE	81
CHAN_BOND_WAIT,	
CHAN_BOND_OFFSET,	
CHAN_BOND_LIMIT	82
CHBONDDONE	83
CHBONDI,	
CHBONDO	83
RXCLKCORCNT,	
RXLOSSOFSYNC	83
Troubleshooting	83
CRC (Cyclic Redundancy Check)	84
Overview	84
CRC Operation	84
CRC Generation	84
CRC Latency	85
Ports and Attributes	85
TX_CRC_USE,	
RX_CRC_USE	85
CRC_FORMAT	85
CRC_START_OF_PACKET,	
CRC_END_OF_PACKET	88
RXCHECKINGCRC,	
RXCRCERR	88
TXFORCECRCERR,	
TX_CRC_FORCE_VALUE	89
RocketIO CRC Support Limitations	89
Fabric Interface (Buffers)	89
Overview: Transmitter and Elastic (Receiver) Buffers	89
Transmitter Buffer (FIFO)	89
Receiver Buffer	89
Ports and Attributes	90
TXBUFERR	90
TX_BUFFER_USE	90
RXBUFSTATUS	90
RX_BUFFER_USE	90
Miscellaneous Signals	90
Ports and Attributes	90

RX_DATA_WIDTH,	
TX_DATA_WIDTH	90
SERDES_10B	90
TERMINATION_IMP	91
TXPOLARITY,	
RXPOLARITY,	
TXINHIBIT	91
TX_DIFF_CTRL,	
PRE_EMPHASIS	91
LOOPBACK	91
Other Important Design Notes	93
Receive Data Path 32-bit Alignment	93
32-bit Alignment Design	95
Verilog	95
VHDL	98

Chapter 3: Analog Design Considerations

Serial I/O Description	103
Pre-emphasis Techniques	104
Differential Receiver	107
Jitter	107
Clock and Data Recovery	108
PCB Design Requirements	109
Power Conditioning	109
Voltage Regulator Selection and Use	109
Termination Voltage	110
Passive Filtering	111
High-Speed Serial Trace Design	115
Routing Serial Traces	115
Differential Trace Design	116
AC and DC Coupling	117
Reference Clock	119
Epson EG-2121CA 2.5V (LVPECL Outputs)	119
Pletronics LV1145B (LVDS Outputs)	119
Other Important Design Notes	120
Powering the RocketIO Transceivers	120
Pin Connections on the Unused RocketIO Transceivers	120
The POWERDOWN Port	120

Chapter 4: Simulation and Implementation

Simulation Models	121
SmartModels	121
HSPICE	121
Implementation Tools	121
Par	121
MGT Package Pins	123

Appendix A: RocketIO Transceiver Timing Model

Timing Parameters	129
------------------------------------	------------

Setup/Hold Times of Inputs Relative to Clock	129
Clock to Output Delays	129
Clock Pulse Width	130
Timing Parameter Tables and Diagram	130

Appendix B: 8B/10B Valid Characters

Valid Data Characters	135
Valid Control Characters (K-Characters)	143

Appendix C: Related Online Documents

Application Notes	145
XAPP572: A 3/4/5/6X Oversampling Circuit for 200 Mb/s to 1000 Mb/s Serial Interfaces	145
XAPP648: Serial Backplane Interface to a Shared Memory	145
XAPP649: SONET Rate Conversion in Virtex-II Pro Devices	146
XAPP651: SONET and OTN Scramblers/Descramblers	146
XAPP652: Word Alignment and SONET/SDH Deframing	146
XAPP660: Partial Reconfiguration of RocketIO Pre-emphasis and Differential Swing Control Attributes	146
XAPP661: RocketIO Transceiver Bit-Error Rate Tester	147
XAPP662: In-Circuit Partial Reconfiguration of RocketIO Attributes	147
XAPP669: PPC405 PPE Reference System Using Virtex-II Pro RocketIO Transceivers	147
XAPP670: Minimizing Receiver Elastic Buffer Delay in the Virtex-II Pro RocketIO Transceiver	148
XAPP680: HD-SDI Transmitter Using Virtex-II Pro RocketIO Multi-Gigabit Transceivers	148
XAPP681: HD-SDI Receiver Using Virtex-II Pro RocketIO Multi-Gigabit Transceivers	148
XAPP683: Multi-Rate HD/SD-SDI Transmitter Using Virtex-II Pro RocketIO Multi-Gigabit Transceivers	148
XAPP684: Multi-Rate HD/SD-SDI Receiver Using Virtex-II Pro RocketIO Multi-Gigabit Transceivers	149
XAPP687: 64B/66B Encoder/Decoder	149
XAPP756: Transmitting DDR Data Between LVDS and RocketIO CML Devices ..	149
XAPP763: Local Clocking for MGT RXRECCLK in Virtex-II Pro Devices	149
Characterization Reports	149
Virtex-II Pro RocketIO Multi-Gigabit Transceiver Characterization Summary	150
Virtex-II Pro RocketIO MGT HSSDC2 Cable Characterization	150
White Papers	150
WP157: Usage Models for Multi-Gigabit Serial Transceivers	150
WP160: Emulating External SERDES Devices with Embedded RocketIO Transceivers	151
Index	153

Schedule of Figures

Chapter 1: RocketIO Transceiver Overview

<i>Figure 1-1: RocketIO Transceiver Block Diagram</i>	22
---	----

Chapter 2: Digital Design Considerations

<i>Figure 2-1: REFCLK/BREFCLK Selection Logic</i>	41
<i>Figure 2-2: Two-Byte Clock with DCM</i>	43
<i>Figure 2-3: Two-Byte Clock without DCM</i>	46
<i>Figure 2-4: Four-Byte Clock</i>	47
<i>Figure 2-5: One-Byte Clock</i>	50
<i>Figure 2-6: One-Byte Data Path Clocks, SERDES_10B = TRUE</i>	54
<i>Figure 2-7: Two-Byte Data Path Clocks, SERDES_10B = TRUE</i>	54
<i>Figure 2-8: Four-Byte Data Path Clocks, SERDES_10B = TRUE</i>	54
<i>Figure 2-9: Multiplexed REFCLK with DCM</i>	55
<i>Figure 2-10: Multiplexed REFCLK without DCM</i>	55
<i>Figure 2-11: Using RXRECCLK to Generate RXUSRCLK and RXUSRCLK2</i>	56
<i>Figure 2-12: 8B/10B Data Flow</i>	61
<i>Figure 2-13: 10-Bit TX Data Map with 8B/10B Bypassed</i>	65
<i>Figure 2-14: 10-Bit RX Data Map with 8B/10B Bypassed</i>	65
<i>Figure 2-15: 8B/10B Parallel to Serial Conversion</i>	66
<i>Figure 2-16: 4-Byte Serial Structure</i>	66
<i>Figure 2-17: Synchronizing Comma Align Signals to RXRECCLK</i>	68
<i>Figure 2-18: Top MGT Comma Control Flip-Flop Ideal Locations</i>	69
<i>Figure 2-19: Bottom MGT Comma Control Flip-Flop Ideal Locations</i>	69
<i>Figure 2-20: Clock Correction in Receiver</i>	72
<i>Figure 2-21: RXLOSSOFSYNC FSM States</i>	78
<i>Figure 2-22: Channel Bonding (Alignment)</i>	79
<i>Figure 2-23: CRC Packet Format</i>	84
<i>Figure 2-24: USER_MODE / FIBRE_CHAN Mode</i>	86
<i>Figure 2-25: Ethernet Mode</i>	87
<i>Figure 2-26: Infiniband Mode</i>	87
<i>Figure 2-27: Local Route Header</i>	88
<i>Figure 2-28: Serial and Parallel Loopback Logic</i>	93
<i>Figure 2-29: RXDATA Aligned Correctly</i>	94
<i>Figure 2-30: Realignment of RXDATA</i>	94

Chapter 3: Analog Design Considerations

<i>Figure 3-1: Differential Amplifier</i>	103
<i>Figure 3-2: Alternating K28.5+ with No Pre-Emphasis</i>	105

<i>Figure 3-3: K28.5+ with Pre-Emphasis</i>	105
<i>Figure 3-4: Eye Diagram, 10% Pre-Emphasis, 20" FR4, Worst-Case Conditions</i>	106
<i>Figure 3-5: Eye Diagram, 33% Pre-Emphasis, 20" FR4, Worst-Case Conditions</i>	106
<i>Figure 3-6: MGT Receiver</i>	107
<i>Figure 3-7: Power Supply Circuit Using Approved Regulator</i>	110
<i>Figure 3-8: Power Filtering Network on Devices with Internal & External Capacitors</i>	111
<i>Figure 3-9: Example Power Filtering PCB Layout for Four MGTs, in Device with Internal Capacitors, Bottom Layer</i>	113
<i>Figure 3-10: Example Power Filtering PCB Layout for Four MGTs, In Device with External Capacitors, Top Layer</i>	114
<i>Figure 3-11: Example Power Filtering PCB Layout for Four MGTs, in Device with External Capacitors, Bottom Layer</i>	115
<i>Figure 3-12: Single-Ended Trace Geometry</i>	116
<i>Figure 3-13: Microstrip Edge-Coupled Differential Pair</i>	117
<i>Figure 3-14: Stripline Edge-Coupled Differential Pair</i>	117
<i>Figure 3-15: AC-Coupled Serial Link</i>	117
<i>Figure 3-16: DC-Coupled Serial Link</i>	118
<i>Figure 3-17: LVPECL Reference Clock Oscillator Interface</i>	119
<i>Figure 3-18: LVPECL Reference Clock Oscillator Interface (On-Chip Termination)</i>	119
<i>Figure 3-19: LVDS Reference Clock Oscillator Interface</i>	119
<i>Figure 3-20: LVDS Reference Clock Oscillator Interface (On-Chip Termination)</i>	119

Chapter 4: Simulation and Implementation

<i>Figure 4-1: XC2VP2 Implementation</i>	122
<i>Figure 4-2: XC2VP50 Implementation</i>	122

Appendix A: RocketIO Transceiver Timing Model

<i>Figure A-1: RocketIO Transceiver Block Diagram</i>	128
<i>Figure A-2: RocketIO Transceiver Timing Relative to Clock Edge</i>	133

Appendix B: 8B/10B Valid Characters

Appendix C: Related Online Documents

Schedule of Tables

Chapter 1: RocketIO Transceiver Overview

<i>Table 1-1: Number of RocketIO Cores per Device Type</i>	21
<i>Table 1-2: Communications Standards Supported by RocketIO Transceiver</i>	21
<i>Table 1-3: Serial Baud Rates and the SERDES_10B Attribute</i>	22
<i>Table 1-4: Supported RocketIO Transceiver Primitives</i>	23
<i>Table 1-5: GT_CUSTOM⁽¹⁾, GT_AURORA, GT_FIBRE_CHAN⁽²⁾, GT_ETHERNET⁽²⁾, GT_INFINIBAND, and GT_XAUI Primitive Ports</i>	24
<i>Table 1-6: RocketIO Transceiver Attributes</i>	29
<i>Table 1-7: Default Attribute Values: GT_AURORA, GT_CUSTOM, GT_ETHERNET.</i> 34	
<i>Table 1-8: Default Attribute Values: GT_FIBRE_CHAN, GT_INFINIBAND, and GT_XAUI.</i>	36
<i>Table 1-9: Control/Status Bus Association to Data Bus Byte Paths.</i>	38

Chapter 2: Digital Design Considerations

<i>Table 2-1: Clock Ports.</i>	40
<i>Table 2-2: Reference Clock Usage</i>	40
<i>Table 2-3: BREFCLK Pin Numbers</i>	41
<i>Table 2-4: Data Width Clock Ratios</i>	42
<i>Table 2-5: DCM Outputs for Different DATA_WIDTHs</i>	43
<i>Table 2-6: Latency through Various Transmitter Components/Processes.</i>	57
<i>Table 2-7: Latency through Various Receiver Components/Processes.</i>	57
<i>Table 2-8: Reset and Power Control Descriptions</i>	58
<i>Table 2-9: Power Control Descriptions.</i>	58
<i>Table 2-10: 8B/10B Bypassed Signal Significance</i>	62
<i>Table 2-11: Running Disparity Control</i>	63
<i>Table 2-12: Possible Locations of Comma Character.</i>	68
<i>Table 2-13: Effects of Comma-Related Ports and Attributes</i>	71
<i>Table 2-14: Data Bytes Allowed Between Clock Corrections as a Function of REFCLK Stability and IDLE Sequences Removed</i>	73
<i>Table 2-15: Clock Correction Sequence / Data Correlation for 16-Bit Data Port</i>	74
<i>Table 2-16: Applicable Clock Correction Sequences.</i>	75
<i>Table 2-17: RXCLKCORCNT Definition</i>	76
<i>Table 2-18: Bonded Channel Connections.</i>	80
<i>Table 2-19: Master/Slave Channel Bonding Attribute Settings.</i>	81
<i>Table 2-20: Effects of CRC on Transceiver Latency⁽¹⁾</i>	85
<i>Table 2-21: Global and Local Headers</i>	88
<i>Table 2-22: Serial Speed Ranges as a Function of SERDES_10B.</i>	91
<i>Table 2-23: LOOPBACK Modes.</i>	92
<i>Table 2-24: 32-bit RXDATA, Aligned versus Misaligned.</i>	94

Chapter 3: Analog Design Considerations

<i>Table 3-1: Differential Transmitter Parameters</i>	103
<i>Table 3-2: Pre-emphasis Values</i>	104
<i>Table 3-3: Differential Receiver Parameters</i>	107
<i>Table 3-4: CDR Parameters</i>	108
<i>Table 3-5: Transceiver Power Supply Ranges</i>	109
<i>Table 3-6: Qualified Linear Regulators</i>	110
<i>Table 3-7: Device and Package Combinations showing Devices with RocketIO Power Filtering Capacitors Internal to the Package and Externally Mounted on the PCB</i>	112
<i>Table 3-8: Recommended V_{TRX} and V_{TTX} for AC- and DC-Coupled Environments</i> ..	118

Chapter 4: Simulation and Implementation

<i>Table 4-1: LOC Grid & Package Pins Correlation for FG256/456 & FF672</i>	123
<i>Table 4-2: LOC Grid & Package Pins Correlation for FG676, FF896, and FF1152</i>	124
<i>Table 4-3: LOC Grid & Package Pins Correlation for FF1517 and FF1704</i>	125

Appendix A: RocketIO Transceiver Timing Model

<i>Table A-1: RocketIO Clock Descriptions</i>	127
<i>Table A-2: Parameters Relative to the RX User Clock (RXUSRCLK)</i>	130
<i>Table A-3: Parameters Relative to the RX User Clock2 (RXUSRCLK2)</i>	131
<i>Table A-4: Parameters Relative to the TX User Clock2 (TXUSRCLK2)</i>	131
<i>Table A-5: Miscellaneous Clock Parameters</i>	132

Appendix B: 8B/10B Valid Characters

<i>Table B-1: Valid Data Characters</i>	135
<i>Table B-2: Valid Control Characters (K-Characters)</i>	143

Appendix C: Related Online Documents



About This Guide

The *RocketIO Transceiver User Guide* provides the product designer with the detailed technical information needed to successfully implement the RocketIO™ multi-gigabit transceiver in Virtex-II Pro Platform FPGA designs.

RocketIO Features

The RocketIO transceiver's flexible, programmable features allow a multi-gigabit serial transceiver to be easily integrated into any Virtex-II Pro design:

- Variable-speed, full-duplex transceiver, allowing 600 Mb/s to 3.125 Gb/s baud transfer rates
- Monolithic clock synthesis and clock recovery system, eliminating the need for external components
- Automatic lock-to-reference function
- Five levels of programmable serial output differential swing (800 mV to 1600 mV peak-peak), allowing compatibility with other serial system voltage levels
- Four levels of programmable pre-emphasis
- AC and DC coupling
- Programmable 50Ω/75Ω on-chip termination, eliminating the need for external termination resistors
- Serial and parallel TX-to-RX internal loopback modes for testing operability
- Programmable comma detection to allow for any protocol and detection of any 10-bit character.

Guide Contents

The *RocketIO Transceiver User Guide* contains these sections:

- Preface, "About This Guide" — This section.
- [Chapter 1, "RocketIO Transceiver Overview"](#) — An overview of the transceiver's capabilities and how it works.
- [Chapter 2, "Digital Design Considerations"](#) — Ports and attributes for the six provided communications protocol primitives; VHDL/Verilog code examples for clocking and reset schemes; transceiver instantiation; 8B/10B encoding; CRC; channel bonding.
- [Chapter 3, "Analog Design Considerations"](#) — RocketIO serial overview; pre-emphasis; jitter; clock/data recovery; PCB design requirements.

- [Chapter 4, “Simulation and Implementation”](#) — Simulation models; implementation tools; debugging and diagnostics.
- [Appendix A, “RocketIO Transceiver Timing Model”](#) — Timing parameters associated with the RocketIO transceiver core.
- [Appendix B, “8B/10B Valid Characters”](#) — Valid data and K-characters.
- [Appendix C, “Related Online Documents”](#) — Bibliography of online Application Notes, Characterization Reports, and White Papers.

For More Information

For a complete menu of online information resources available on the Xilinx website, visit <http://www.xilinx.com/virtex2pro/> or refer to [Appendix C, “Related Online Documents.”](#)

For a comprehensive listing of available tutorials and resources on network technologies and communications protocols, visit <http://www.iol.unh.edu/training/>.

Additional Resources

For additional information, go to <http://support.xilinx.com>. The following table lists some of the resources you can access from this website. You can also directly access these resources using the provided URLs.

Resource	Description/URL
Tutorials	Tutorials covering Xilinx design flows, from design entry to verification and debugging http://support.xilinx.com/support/techsup/tutorials/index.htm
Answer Browser	Database of Xilinx solution records http://support.xilinx.com/xlnx/xil_ans_browser.jsp
Application Notes	Descriptions of device-specific design techniques and approaches http://support.xilinx.com/apps/appsweb.htm
Data Sheets	Device-specific information on Xilinx device characteristics, including readback, boundary scan, configuration, length count, and debugging http://support.xilinx.com/xlnx/xweb/xil_publications_index.jsp
Problem Solvers	Interactive tools that allow you to troubleshoot your design issues http://support.xilinx.com/support/troubleshoot/psolvers.htm
Tech Tips	Latest news, design tips, and patch information for the Xilinx design environment http://www.support.xilinx.com/xlnx/xil_tt_home.jsp

Conventions

This document uses the following conventions. An example illustrates each typographical and online convention.

Port and Attribute Names

Input and output ports of the RocketIO transceiver primitives are denoted in upper-case letters. Attributes of the RocketIO transceiver are denoted in upper-case letters with underscores. Trailing numbers in primitive names denote the byte width of the data path. These values are preset and not modifiable. When assumed to be the same frequency, RXUSRCLK and TXUSRCLK are referred to as USRCLK and can be used interchangeably. This also holds true for RXUSRCLK2, TXUSRCLK2, and USRCLK2.

Comma Definition

A *comma* is a “K-character” used by the transceiver to align the serial data on a byte/half-word boundary (depending on the protocol used), so that the serial data is correctly decoded into parallel data.

Typographical

The following typographical conventions are used in this document:

Convention	Meaning or Use	Example
Courier font	Messages, prompts, and program files that the system displays	speed grade: - 100
Courier bold	Literal commands that you enter in a syntactical statement	ngdbuild <i>design_name</i>
Helvetica bold	Commands that you select from a menu	File → Open
	Keyboard shortcuts	Ctrl+C
<i>Italic font</i>	Variables in a syntax statement for which you must supply values	ngdbuild <i>design_name</i>
	References to other manuals	See the <i>Development System Reference Guide</i> for more information.
	Emphasis in text	If a wire is drawn so that it overlaps the pin of a symbol, the two nets are <i>not</i> connected.
Square brackets []	An optional entry or parameter. However, in bus specifications, such as bus [7:0] , they are required.	ngdbuild [<i>option_name</i>] <i>design_name</i>
Braces { }	A list of items from which you must choose one or more	lowpwr = { on off }

Convention	Meaning or Use	Example
Vertical bar	Separates items in a list of choices	lowpwr = { on off }
Vertical ellipsis .	Repetitive material that has been omitted	IOB #1: Name = QOUT' IOB #2: Name = CLKIN' . . .
Horizontal ellipsis ...	Repetitive material that has been omitted	allow block <i>block_name</i> <i>loc1 loc2 ... locn</i> ;

Online Document

The following conventions are used in this document:

Convention	Meaning or Use	Example
Blue text	Cross-reference link to a location in the current document	See the section " Additional Resources " for details. Refer to " Title Formats " in Chapter 1 for details.
Red text	Cross-reference link to a location in another document	See Figure 2-5 in the <i>Virtex-II Handbook</i> .
Blue, underlined text	Hyperlink to a website (URL)	Go to http://www.xilinx.com for the latest speed files.



RocketIO Transceiver Overview

Basic Architecture and Capabilities

The RocketIO transceiver is based on Mindspeed's SkyRail™ technology. [Figure 1-1, page 22](#), depicts an overall block diagram of the transceiver. Up to 20 transceiver modules are available on a single Virtex-II Pro FPGA, depending on the part being used. [Table 1-1](#) shows the RocketIO cores available by device.

Table 1-1: Number of RocketIO Cores per Device Type

Device	RocketIO Cores	Device	RocketIO Cores
XC2VP2	4	XC2VP40	0 or 12
XC2VP4	4	XC2VP50	0 or 16
XC2VP7	8	XC2VP70	16 or 20
XC2VP20	8	XC2VP100	0 or 20
XC2VP30	8		

The transceiver module is designed to operate at any serial bit rate in the range of 600 Mb/s to 3.125 Gb/s per channel, including the specific bit rates used by the communications standards listed in [Table 1-2](#). The serial bit rate need not be configured in the transceiver, as the operating frequency is implied by the received data, the reference clock applied, and the SERDES_10B attribute (see [Table 1-3](#)).

Table 1-2: Communications Standards Supported by RocketIO Transceiver

Mode	Channels (Lanes) ⁽¹⁾	I/O Bit Rate (Gb/s)
Fibre Channel	1	1.06
		2.12
Gbit Ethernet	1	1.25
PCI Express ⁽²⁾	1	2.5
XAUI (10-Gbit Ethernet)	4	3.125
XAUI (10-Gbit Fibre Channel) ⁽³⁾	4	3.1875 ⁽⁴⁾
Infiniband	1, 4, 12	2.5
Aurora (Xilinx protocol)	1, 2, 3, 4,...	0.600 – 3.125
Custom Mode	1, 2, 3, 4,...	0.600 – 3.125

Notes:

1. One channel is considered to be one transceiver.
2. Out-of-Band (OOB) signals are not supported with the transceiver.
3. Supported with the GT_CUSTOM primitive. Certain attributes must be modified to comply with the XAUI 10GFC specifications, including but not limited to CLK_COR_SEQ and CHAN_BOND_SEQ.
4. Bit rate is possible with the following topology specification: maximum 6" FR4 and one Molex 74441 connector.

Table 1-3: Serial Baud Rates and the SERDES_10B Attribute

SERDES_10B	Serial Baud Rate
FALSE	1.0 Gb/s – 3.125 Gb/s
TRUE	600 Mb/s – 1.0 Gb/s

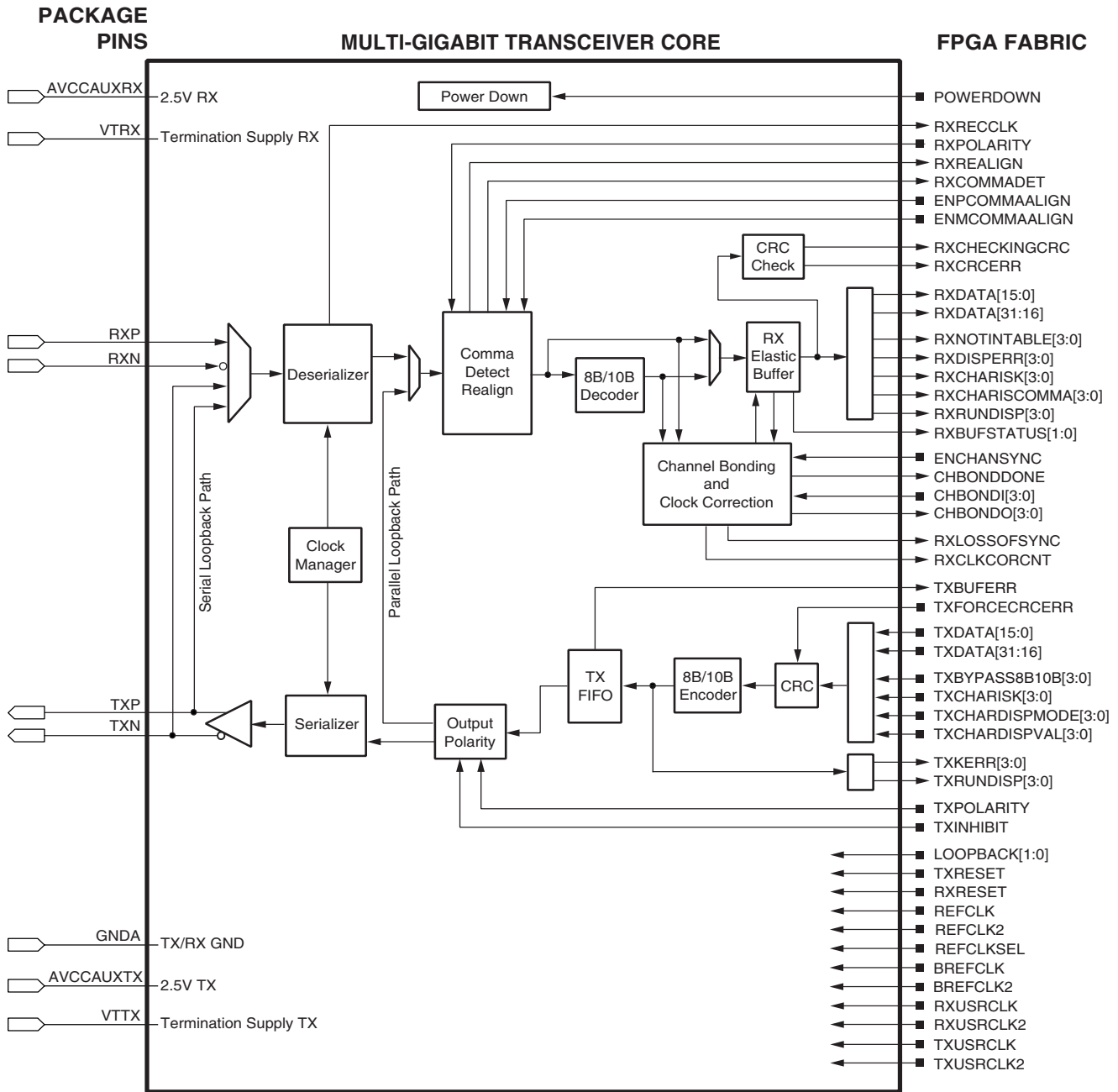

DS083-2_04_090402

Figure 1-1: RocketIO Transceiver Block Diagram

Table 1-4 lists the sixteen gigabit transceiver primitives provided. These primitives carry attributes set to default values for the communications protocols listed in Table 1-2. Data widths of one, two, and four bytes are selectable for each protocol.

Table 1-4: Supported RocketIO Transceiver Primitives

Primitives	Description	Primitive	Description
GT_CUSTOM	Fully customizable by user	GT_XAUI_2	10-Gb Ethernet, 2-byte data path
GT_FIBRE_CHAN_1	Fibre Channel, 1-byte data path	GT_XAUI_4	10-Gb Ethernet, 4-byte data path
GT_FIBRE_CHAN_2	Fibre Channel, 2-byte data path	GT_INFINIBAND_1	Infiniband, 1-byte data path
GT_FIBRE_CHAN_4	Fibre Channel, 4-byte data path	GT_INFINIBAND_2	Infiniband, 2-byte data path
GT_ETHERNET_1	Gigabit Ethernet, 1-byte data path	GT_INFINIBAND_4	Infiniband, 4-byte data path
GT_ETHERNET_2	Gigabit Ethernet, 2-byte data path	GT_AURORA_1	Xilinx protocol, 1-byte data path
GT_ETHERNET_4	Gigabit Ethernet, 4-byte data path	GT_AURORA_2	Xilinx protocol, 2-byte data path
GT_XAUI_1	10-Gb Ethernet, 1-byte data path	GT_AURORA_4	Xilinx protocol, 4-byte data path

There are two ways to modify the RocketIO transceiver:

- Static properties can be set through attributes in the HDL code. Use of attributes are covered in detail in “Primitive Attributes,” page 29.
- Dynamic changes can be made by the ports of the primitives

The RocketIO transceiver consists of the Physical Media Attachment (PMA) and Physical Coding Sublayer (PCS). The PMA contains the serializer/deserializer (SERDES), TX and RX buffers, clock generator, and clock recovery circuitry. The PCS contains the 8B/10B encoder/decoder and the elastic buffer supporting channel bonding and clock correction. The PCS also handles Cyclic Redundancy Check (CRC). Refer again to Figure 1-1, showing the RocketIO transceiver top-level block diagram and FPGA interface signals.

RocketIO Transceiver Instantiations

For the different clocking schemes, several things must change, including the clock frequency for USRCLK and USRCLK2 discussed in “Digital Clock Manager (DCM) Examples” in Chapter 2. The data and control ports for GT_CUSTOM must also reflect this change in data width by concatenating zeros onto inputs and wires for outputs for Verilog designs, and by setting outputs to open and concatenating zeros on unused input bits for VHDL designs.

HDL Code Examples

Please use the Architecture Wizard to create instantiation templates. This wizard creates code and instantiation templates that define the attributes for a specific application.

List of Available Ports

The RocketIO transceiver primitives contain 50 ports, with the exception of the 46-port GT_ETHERNET and GT_FIBRE_CHAN primitives. The differential serial data ports (RXN, RXP, TXN, and TXP) are connected directly to external pads; the remaining 46 ports are all accessible from the FPGA logic (42 ports for GT_ETHERNET and GT_FIBRE_CHAN).

Table 1-5 contains the port descriptions of all primitives.

Table 1-5: GT_CUSTOM⁽¹⁾, GT_AURORA, GT_FIBRE_CHAN⁽²⁾, GT_ETHERNET⁽²⁾, GT_INFINIBAND, and GT_XAUI Primitive Ports

Port	I/O	Port Size	Definition
BREFCLK	I	1	This high-quality reference clock uses dedicated routing to improve jitter for serial speeds of 2.5 Gb/s or greater. See Table 2-2, page 40 for usage cases.
BREFCLK2	I	1	Alternative to BREFCLK. Can be selected by REFCLKSEL.
CHBONDDONE ⁽²⁾	O	1	Indicates a receiver has successfully completed channel bonding when asserted High.
CHBONDI ⁽²⁾	I	4	The channel bonding control that is used only by “slaves” which is driven by a transceiver's CHBONDO port.
CHBONDO ⁽²⁾	O	4	Channel bonding control that passes channel bonding and clock correction control to other transceivers.
CONFIGENABLE	I	1	Reconfiguration enable input (unused). Should be set to logic 0.
CONFIGIN	I	1	Data input for reconfiguring transceiver (unused). Should be set to logic 0.
CONFIGOUT	O	1	Data output for configuration readback (unused). Should be left unconnected.
ENCHANSYNC ⁽²⁾	I	1	Comes from the core to the transceiver and enables the transceiver to perform channel bonding
ENMCOMMAALIGN	I	1	Selects realignment of incoming serial bitstream on minus-comma. High realigns serial bitstream byte boundary when minus-comma is detected.
ENPCOMMAALIGN	I	1	Selects realignment of incoming serial bitstream on plus-comma. High realigns serial bitstream byte boundary when plus-comma is detected.
LOOPBACK	I	2	Selects the two loopback test modes. Bit 1 is for serial loopback and bit 0 is for internal parallel loopback.
POWERDOWN	I	1	Shuts down both the receiver and transmitter sides of the transceiver when asserted High. This decreases the power consumption while the transceiver is shut down. This input is asynchronous.

Product Not Recommended for New Designs

Table 1-5: GT_CUSTOM⁽¹⁾, GT_AURORA, GT_FIBRE_CHAN⁽²⁾, GT_ETHERNET⁽²⁾, GT_INFINIBAND, and GT_XAUI Primitive Ports (*Continued*)

Port	I/O	Port Size	Definition
REFCLK	I	1	High-quality reference clock driving transmission (reading TX FIFO, and multiplied for parallel/serial conversion) and clock recovery. REFCLK frequency is accurate to ± 100 ppm. When running an asynchronous system, this accuracy must be met by both reference clocks. This clock originates off the device, is routed through fabric interconnect, and is selected by REFCLKSEL.
REFCLK2	I	1	An alternative to REFCLK. Can be selected by REFCLKSEL.
REFCLKSEL	I	1	Selects the reference clock to use: Low = selects REFCLK if REF_CLK_V_SEL = 0 selects BREFCLK if REF_CLK_V_SEL = 1 High = selects REFCLK2 if REF_CLK_V_SEL = 0 selects BREFCLK2 if REF_CLK_V_SEL = 1 See “REF_CLK_V_SEL,” page 32.
RXBUFSTATUS	O	2	Receiver elastic buffer status. Bit 1 indicates if an overflow/underflow error has occurred when asserted High. Bit 0 indicates that the buffer is at least half-full when asserted High.
RXCHARISCOMMA ⁽³⁾	O	1, 2, 4	Similar to RXCHARISK except that the data is a comma.
RXCHARISK ⁽³⁾	O	1, 2, 4	If 8B/10B decoding is enabled, it indicates that the received data is a K-character when asserted High. Included in Byte-mapping. If 8B/10B decoding is bypassed, it remains as the first bit received (Bit “a”) of the 10-bit encoded data (see Figure 2-14, page 65).
RXCHECKINGCRC	O	1	CRC status for the receiver. Asserts High to indicate that the receiver has recognized the end of a data packet. Only meaningful if RX_CRC_USE = TRUE.
RXCLKCORCNT	O	3	Status that denotes occurrence of clock correction or channel bonding. This status is synchronized on the incoming RXDATA. See “RXCLKCORCNT,” page 76.
RXCOMMADET	O	1	Signals that a comma has been detected in the data stream. To assure signal is reliably brought out to the fabric for different data paths, this signal may remain High for more than one USRCLK/USRCLK2 cycle.
RXCRCERR	O	1	Indicates if the CRC code is incorrect when asserted High. Only meaningful if RX_CRC_USE = TRUE.
RXDATA ⁽³⁾	O	8, 16, 32	Up to four bytes of decoded (8B/10B encoding) or encoded (8B/10B bypassed) receive data.
RXDISPERR ⁽³⁾	O	1, 2, 4	If 8B/10B encoding is enabled it indicates whether a disparity error has occurred on the serial line. Included in Byte-mapping scheme.

Table 1-5: GT_CUSTOM⁽¹⁾, GT_AURORA, GT_FIBRE_CHAN⁽²⁾, GT_ETHERNET⁽²⁾, GT_INFINIBAND, and GT_XAUI Primitive Ports (*Continued*)

Port	I/O	Port Size	Definition
RXLOSSOFSYNC	O	2	Status related to byte-stream synchronization (RX_LOSS_OF_SYNC_FSM) If RX_LOSS_OF_SYNC_FSM = TRUE, RXLOSSOFSYNC indicates the state of the FSM: Bit 1 = Loss of sync (High) Bit 0 = Resync state (High) If RX_LOSS_OF_SYNC_FSM = FALSE, RXLOSSOFSYNC indicates: Bit 1 = Received data invalid (High) Bit 0 = Channel bonding sequence recognized (High)
RXN ⁽⁴⁾	I	1	Serial differential port (FPGA external)
RXNOTINTABLE ⁽³⁾	O	1, 2, 4	Status of encoded data when the data is not a valid character when asserted High. Applies to the byte-mapping scheme.
RXP ⁽⁴⁾	I	1	Serial differential port (FPGA external)
RXPOLARITY	I	1	Similar to TXPOLARITY, but for RXN and RXP. When de-asserted, assumes regular polarity. When asserted, reverses polarity.
RXREALIGN	O	1	Signal from the PMA denoting that the byte alignment with the serial data stream changed due to a comma detection. Asserted High when alignment occurs.
RXRECCLK	O	1	Clock recovered from the data stream by dividing its speed by 20.
RXRESET	I	1	Synchronous RX system reset that “recenters” the receive elastic buffer. It also resets 8B/10B decoder, comma detect, channel bonding, clock correction logic, and other internal receive registers. It does not reset the receiver PLL.
RXRUNDISP ⁽³⁾	O	1, 2, 4	Signals the running disparity (0 = negative, 1 = positive) in the received serial data. If 8B/10B encoding is bypassed, it remains as the second bit received (Bit “b”) of the 10-bit encoded data (see Figure 2-14, page 65).
RXUSRCLK	I	1	Clock from a DCM or a BUFG that is used for reading the RX elastic buffer. It also clocks CHBONDI and CHBONDO in and out of the transceiver. Typically, the same as TXUSRCLK.
RXUSRCLK2	I	1	Clock output from a DCM that clocks the receiver data and status between the transceiver and the FPGA core. Typically the same as TXUSRCLK2. The relationship between RXUSRCLK and RXUSRCLK2 depends on the width of RXDATA.
TXBUFERR	O	1	Provides status of the transmission FIFO. If asserted High, an overflow/underflow has occurred. When this bit becomes set, it can only be reset by asserting TXRESET.
TXBYPASS8B10B ⁽³⁾	I	1, 2, 4	This control signal determines whether the 8B/10B encoding is enabled or bypassed. If the signal is asserted High, the encoding is bypassed. This creates a 10-bit interface to the FPGA core. See the 8B/10B section for more details.

Product Not Recommended for New Designs

Table 1-5: GT_CUSTOM⁽¹⁾, GT_AURORA, GT_FIBRE_CHAN⁽²⁾, GT_ETHERNET⁽²⁾, GT_INFINIBAND, and GT_XAUI Primitive Ports (Continued)

Port	I/O	Port Size	Definition
TXCHARDISPMODE ⁽³⁾	I	1, 2, 4	If 8B/10B encoding is enabled, this bus determines what mode of disparity is to be sent. When 8B/10B is bypassed, this becomes the first bit transmitted (Bit “a”) of the 10-bit encoded TXDATA bus section (see Figure 2-13, page 65) for each byte specified by the byte-mapping.
TXCHARDISPVAL ⁽³⁾	I	1, 2, 4	If 8B/10B encoding is enabled, this bus determines what type of disparity is to be sent. When 8B/10B is bypassed, this becomes the second bit transmitted (Bit “b”) of the 10-bit encoded TXDATA bus section (see Figure 2-13, page 65) for each byte specified by the byte-mapping section.
TXCHARISK ⁽³⁾	I	1, 2, 4	If 8B/10B encoding is enabled, this control bus determines if the transmitted data is a K-character or a Data character. A logic High indicates a K-character.
TXDATA ⁽³⁾	I	8, 16, 32	Transmit data that can be 1, 2, or 4 bytes wide, depending on the primitive used. TXDATA [7:0] is always the last byte transmitted. The position of the first byte depends on selected TX data path width.
TXFORCECRCERR	I	1	Specifies whether to insert error in computed CRC. When TXFORCECRCERR = TRUE, the transmitter corrupts the correctly computed CRC value by XORing with the bits specified in attribute TX_CRC_FORCE_VALUE. This input can be used to test detection of CRC errors at the receiver.
TXINHIBIT	I	1	If a logic High, the TX differential pairs are forced to be a constant 1/0. TXN = 1, TXP = 0
TXKERR ⁽³⁾	O	1, 2, 4	If 8B/10B encoding is enabled, this signal indicates (High) when the K-character to be transmitted is not a valid K-character. Bits correspond to the byte-mapping scheme.
TXN ⁽⁴⁾	O	1	Transmit differential port (FPGA external)
TXP ⁽⁴⁾	O	1	Transmit differential port (FPGA external)
TXPOLARITY	I	1	Specifies whether or not to invert the final transmitter output. Able to reverse the polarity on the TXN and TXP lines. Deasserted sets regular polarity. Asserted reverses polarity.
TXRESET	I	1	Synchronous TX system reset that “recenters” the transmit elastic buffer. It also resets 8B/10B encoder and other internal transmission registers. It does not reset the transmission PLL.
TXRUNDISP ⁽³⁾	O	1, 2, 4	Signals the running disparity after this byte is encoded. Low indicates negative disparity, High indicates positive disparity.
TXUSRCLK	I	1	Clock output from a DCM or a BUFG that is clocked with a reference clock. This clock is used for writing the TX buffer and is frequency-locked to the reference clock.

Table 1-5: GT_CUSTOM⁽¹⁾, GT_AURORA, GT_FIBRE_CHAN⁽²⁾, GT_ETHERNET⁽²⁾, GT_INFINIBAND, and GT_XAUI Primitive Ports (*Continued*)

Port	I/O	Port Size	Definition
TXUSRCLK2	I	1	Clock output from a DCM that clocks transmission data and status and reconfiguration data between the transceiver and the FPGA core. The ratio between TXUSRCLK and TXUSRCLK2 depends on the width of TXDATA.

Notes:

1. The GT_CUSTOM ports are always the maximum port size.
2. GT_FIBRE_CHAN and GT_ETHERNET ports do not have the three CHBOND** or ENCHANSYNC ports.
3. The port size changes with relation to the primitive selected, and also correlates to the byte mapping.
4. External ports only accessible from package pins.

Primitive Attributes

The primitives also contain attributes set by default to specific values controlling each specific primitive’s protocol parameters. Included are channel-bonding settings (for primitives supporting channel bonding), clock correction sequences, and CRC. [Table 1-6](#) shows a brief description of each attribute. [Table 1-7](#) and [Table 1-8](#) have the default values of each primitive.

Table 1-6: RocketIO Transceiver Attributes

Attribute	Description
ALIGN_COMMA_MSB	<p>TRUE/FALSE controls the alignment of detected commas within the transceiver’s 2-byte-wide data path.</p> <p>FALSE: Align commas within a 10-bit alignment range. As a result the comma is aligned to either RXDATA[15:8] byte or RXDATA [7:0] byte in the transceivers internal data path.</p> <p>TRUE: Aligns comma with 20-bit alignment range.</p> <p>As a result aligns on the RXDATA[15:8] byte.</p> <p>Notes:</p> <ol style="list-style-type: none"> 1. If protocols (like Gigabit Ethernet) are oriented in byte pairs with commas always in even (first) byte formation, this can be set to TRUE. Otherwise, it should be set to FALSE. 2. For 32-bit data path primitives, see “32-bit Alignment Design,” page 95. 3. This attribute is only modifiable in the GT_CUSTOM primitive.
CHAN_BOND_LIMIT	<p>Integer 1-31 that defines maximum number of bytes a slave receiver can read following a channel bonding sequence and still successfully align to that sequence.</p>
CHAN_BOND_MODE	<p>STRING</p> <p>OFF, MASTER, SLAVE_1_HOP, SLAVE_2_HOPS</p> <p>OFF: No channel bonding involving this transceiver.</p> <p>MASTER: This transceiver is master for channel bonding. Its CHBONDO port directly drives CHBONDI ports on one or more SLAVE_1_HOP transceivers.</p> <p>SLAVE_1_HOP: This transceiver is a slave for channel bonding. SLAVE_1_HOP’s CHBONDI is directly driven by a MASTER transceiver CHBONDO port. SLAVE_1_HOP’s CHBONDO port can directly drive CHBONDI ports on one or more SLAVE_2_HOPS transceivers.</p> <p>SLAVE_2_HOPS: This transceiver is a slave for channel bonding. SLAVE_2_HOPS CHBONDI is directly driven by a SLAVE_1_HOP CHBONDO port.</p>

Table 1-6: RocketIO Transceiver Attributes (Continued)

Attribute	Description
CHAN_BOND_OFFSET	<p>Integer 0-15 that defines offset (in bytes) from channel bonding sequence for realignment. It specifies the first elastic buffer read address that all channel-bonded transceivers have immediately after channel bonding.</p> <p>CHAN_BOND_WAIT specifies the number of bytes that the master transceiver passes to RXDATA, starting with the channel bonding sequence, before the transceiver executes channel bonding (alignment) across all channel-bonded transceivers.</p> <p>CHAN_BOND_OFFSET specifies the first elastic buffer read address that all channel-bonded transceivers have immediately after channel bonding (alignment), as a positive offset from the beginning of the matched channel bonding sequence in each transceiver.</p> <p>For optimal performance of the elastic buffer, CHAN_BOND_WAIT and CHAN_BOND_OFFSET should be set to the same value (typically 8).</p>
CHAN_BOND_ONE_SHOT	<p>TRUE/FALSE that controls repeated execution of channel bonding.</p> <p>FALSE: Master transceiver initiates channel bonding whenever possible (whenever channel-bonding sequence is detected in the input) as long as input ENCHANSYNC is High and RXRESET is Low.</p> <p>TRUE: Master transceiver initiates channel bonding only the first time it is possible (channel bonding sequence is detected in input) following negated RXRESET and asserted ENCHANSYNC. After channel-bonding alignment is done, it does not occur again until RXRESET is asserted and negated, or until ENCHANSYNC is negated and reasserted.</p> <p>Always set Slave transceivers CHAN_BOND_ONE_SHOT to FALSE.</p>
CHAN_BOND_SEQ_*_*	<p>11-bit vectors that define the channel bonding sequence. The usage of these vectors also depends on CHAN_BOND_SEQ_LEN and CHAN_BOND_SEQ_2_USE. See “Receiving Vitesse Channel Bonding Sequence,” page 65, for format.</p>
CHAN_BOND_SEQ_2_USE	<p>Controls use of second channel bonding sequence.</p> <p>FALSE: Channel bonding uses only one channel bonding sequence defined by CHAN_BOND_SEQ_1_1...4.</p> <p>TRUE: Channel bonding uses two channel bonding sequences defined by:</p> <p style="padding-left: 40px;">CHAN_BOND_SEQ_1_1...4 and CHAN_BOND_SEQ_2_1...4</p> <p>as further constrained by CHAN_BOND_SEQ_LEN.</p>
CHAN_BOND_SEQ_LEN	<p>Integer 1-4 defines length in bytes of channel bonding sequence. This defines the length of the sequence the transceiver matches to detect opportunities for channel bonding.</p>
CHAN_BOND_WAIT	<p>Integer 1-15 that defines the length of wait (in bytes) after seeing channel bonding sequence before executing channel bonding.</p>

Product Not Recommended for New Designs

Table 1-6: RocketIO Transceiver Attributes (Continued)

Attribute	Description
CLK_COR_INSERT_IDLE_FLAG	<p>TRUE/FALSE controls whether RXRUNDISP input status denotes running disparity or inserted-idle flag.</p> <p>FALSE: RXRUNDISP denotes running disparity when RXDATA is decoded data.</p> <p>TRUE: RXRUNDISP is raised for the first byte of each inserted (repeated) clock correction (“Idle”) sequence (when RXDATA is decoded data).</p>
CLK_COR_KEEP_IDLE	<p>TRUE/FALSE controls whether or not the final byte stream must retain at least one clock correction sequence.</p> <p>FALSE: Transceiver can remove all clock correction sequences to further recenter the elastic buffer during clock correction.</p> <p>TRUE: In the final RXDATA stream, the transceiver must leave at least one clock correction sequence per continuous stream of clock correction sequences.</p>
CLK_COR_REPEAT_WAIT	<p>Integer 0 - 31 controls frequency of repetition of clock correction operations. This attribute specifies the minimum number of RXUSRCLK cycles without clock correction that must occur between successive clock corrections. If this attribute is zero, no limit is placed on how frequently clock correction can occur.</p>
CLK_COR_SEQ_*_*	<p>11-bit vectors that define the sequence for clock correction. The attribute used depends on the CLK_COR_SEQ_LEN and CLK_COR_SEQ_2_USE.</p>
CLK_COR_SEQ_2_USE	<p>TRUE/FALSE controls use of second clock correction sequence.</p> <p>FALSE: Clock correction uses only one clock correction sequence defined by CLK_COR_SEQ_1_1...4.</p> <p>TRUE: Clock correction uses two clock correction sequences defined by: CLK_COR_SEQ_1_1...4 and CLK_COR_SEQ_2_1...4 as further constrained by CLK_COR_SEQ_LEN.</p>
CLK_COR_SEQ_LEN	<p>Integer that defines the length of the sequence the transceiver matches to detect opportunities for clock correction. It also defines the size of the correction, since the transceiver executes clock correction by repeating or skipping entire clock correction sequences.</p>
CLK_CORRECT_USE	<p>TRUE/FALSE controls the use of clock correction logic.</p> <p>FALSE: Permanently disable execution of clock correction (rate matching). Clock RXUSRCLK must be frequency-locked with RXRECCLK in this case.</p> <p>TRUE: Enable clock correction (normal mode).</p>
COMMA_10B_MASK	<p>This 10-bit vector defines the mask that is ANDed with the incoming serial bit stream before comparison against PCOMMA_10B_VALUE and MCOMMA_10B_VALUE.</p>

Table 1-6: RocketIO Transceiver Attributes (Continued)

Attribute	Description
CRC_END_OF_PKT	NOTE: This attribute is only valid when CRC_FORMAT = USER_MODE. K28_0, K28_1, K28_2, K28_3, K28_4, K28_5, K28_6, K28_7, K23_7, K27_7, K29_7, K30_7. End-of-packet (EOP) K-character for USER_MODE CRC. Must be one of the 12 legal K-character values.
CRC_FORMAT	ETHERNET, INFINIBAND, FIBRE_CHAN, USER_MODE CRC algorithm selection. Modifiable only for GT_AURORA_n, GT_XAUI_n, and GT_CUSTOM. USER_MODE allows user definition of Start of Packet (SOP) and End of Packet (EOP) K-characters.
CRC_START_OF_PKT	NOTE: This attribute is only valid when CRC_FORMAT = USER_MODE. K28_0, K28_1, K28_2, K28_3, K28_4, K28_5, K28_6, K28_7, K23_7, K27_7, K29_7, K30_7. Start-of-packet (SOP) K-character for USER_MODE CRC. Must be one of the twelve legal K-character values.
DEC_MCOMMA_DETECT	TRUE/FALSE controls the raising of per-byte flag RXCHARISCOMMA on minus-comma.
DEC_PCOMMA_DETECT	TRUE/FALSE controls the raising of per-byte flag RXCHARISCOMMA on plus-comma.
DEC_VALID_COMMA_ONLY	TRUE/FALSE controls the raising of RXCHARISCOMMA on an invalid comma. FALSE: Raise RXCHARISCOMMA on: 0011111xxx (if DEC_PCOMMA_DETECT is TRUE) and/or on: 1100000xxx (if DEC_MCOMMA_DETECT is TRUE) regardless of the settings of the xxx bits. TRUE: Raise RXCHARISCOMMA only on valid characters that are in the 8B/10B translation.
MCOMMA_10B_VALUE	This 10-bit vector defines minus-comma for the purpose of raising RXCOMMADET and realigning the serial bit stream byte boundary. This definition does not affect 8B/10B encoding or decoding. Also see COMMA_10B_MASK.
MCOMMA_DETECT	TRUE/FALSE indicates whether to raise or not raise RXCOMMADET when minus-comma is detected.
PCOMMA_10B_VALUE	This 10-bit vector defines plus-comma for the purpose of raising RXCOMMADET and realigning the serial bit stream byte boundary. This definition does not affect 8B/10B encoding or decoding. Also see COMMA_10B_MASK.
PCOMMA_DETECT	TRUE/FALSE indicates whether to raise or not raise RXCOMMADET when plus-comma is detected.
REF_CLK_V_SEL	1/0: 1: Selects BREFCLK/BREFCLK2 for 2.5 Gb/s or greater serial speeds. 0: Selects REFCLK/REFCLK2 for serial speeds under 2.5 Gb/s.

Product Not Recommended for New Designs

Table 1-6: RocketIO Transceiver Attributes (Continued)

Attribute	Description
RX_BUFFER_USE	Always set to TRUE.
RX_CRC_USE, TX_CRC_USE	TRUE/FALSE determines if CRC is used or not.
RX_DATA_WIDTH, TX_DATA_WIDTH	Integer (1, 2, or 4). Relates to the data width of the FPGA fabric interface.
RX_DECODE_USE	This determines if the 8B/10B decoding is bypassed. FALSE denotes that it is bypassed.
RX_LOS_INVALID_INCR	Power of two in a range of 1 to 128 that denotes the number of valid characters required to “cancel out” appearance of one invalid character for loss of sync determination.
RX_LOS_THRESHOLD	Power of two in a range of 4 to 512. When divided by RX_LOS_INVALID_INCR, denotes the number of invalid characters required to cause FSM transition to “sync lost” state.
RX_LOSS_OF_SYNC_FSM	TRUE/FALSE denotes the nature of RXLOSSOFSYNC output. TRUE: RXLOSSOFSYNC outputs the state of the FSM bits. See “RXLOSSOFSYNC,” page 26, for details.
SERDES_10B	Denotes whether the reference clock is 1/10 or 1/20 the serial bit rate. TRUE: 1/10 (Refer to XAPP572 when considering running in this serial range.) FALSE: 1/20 FALSE supports a serial bitstream range of 1.0 Gb/s to 3.125 Gb/s. TRUE supports a range of 600 Mb/s to 1.0 Gb/s. See “Half-Rate Clocking Scheme,” page 54.
TERMINATION_IMP	Integer (50 or 75). Termination impedance of either 50Ω or 75Ω. Refers to both the RX and TX.
TX_BUFFER_USE	Always set to TRUE.
TX_CRC_FORCE_VALUE	8-bit vector. Value to corrupt TX CRC computation when input TXFORCECRCERR is High. This value is XORed with the correctly computed CRC value, corrupting the CRC if TX_CRC_FORCE_VALUE is nonzero. This can be used to test CRC error detection in the receiver downstream.
TX_DIFF_CTRL	An integer value (400, 500, 600, 700, or 800) representing 400 mV, 500 mV, 600 mV, 700 mV, or 800 mV of voltage difference between the differential lines. Twice this value is the peak-peak voltage.
TX_PREEMPHASIS	An integer value (0-3) that sets the output driver pre-emphasis to improve output waveform shaping for various load conditions. Larger value denotes stronger pre-emphasis. See pre-emphasis values in Table 3-2, page 104 .

Modifiable Primitives

As shown in [Table 1-7](#) and [Table 1-8](#), only certain attributes are modifiable for any primitive. These attributes help to define the protocol used by the primitive. Only the GT_CUSTOM primitive allows the user to modify all of the attributes to a protocol not supported by another transceiver primitive. This allows for complete flexibility. The other primitives allow modification of the analog attributes of the serial data lines and several channel-bonding values.

Table 1-7: Default Attribute Values: GT_AURORA, GT_CUSTOM, GT_ETHERNET

Attribute	Default GT_AURORA	Default GT_CUSTOM ⁽¹⁾	Default GT_ETHERNET
ALIGN_COMMA_MSB	FALSE	FALSE	FALSE
CHAN_BOND_LIMIT	16	16	1
CHAN_BOND_MODE	OFF ⁽²⁾	OFF	OFF
CHAN_BOND_OFFSET	8	8	0
CHAN_BOND_ONE_SHOT	FALSE ⁽²⁾	FALSE	TRUE
CHAN_BOND_SEQ_1_1	00101111100	00000000000	00000000000
CHAN_BOND_SEQ_1_2	00000000000	00000000000	00000000000
CHAN_BOND_SEQ_1_3	00000000000	00000000000	00000000000
CHAN_BOND_SEQ_1_4	00000000000	00000000000	00000000000
CHAN_BOND_SEQ_2_1	00000000000	00000000000	00000000000
CHAN_BOND_SEQ_2_2	00000000000	00000000000	00000000000
CHAN_BOND_SEQ_2_3	00000000000	00000000000	00000000000
CHAN_BOND_SEQ_2_4	00000000000	00000000000	00000000000
CHAN_BOND_SEQ_2_USE	FALSE	FALSE	FALSE
CHAN_BOND_SEQ_LEN	1	1	1
CHAN_BOND_WAIT	8	8	7
CLK_COR_INSERT_IDLE_FLAG	FALSE ⁽²⁾	FALSE	FALSE ⁽²⁾
CLK_COR_KEEP_IDLE	FALSE ⁽²⁾	FALSE	FALSE ⁽²⁾
CLK_COR_REPEAT_WAIT	1 ⁽²⁾	1	1 ⁽²⁾
CLK_COR_SEQ_1_1	00111110111	00000000000	00110111100
CLK_COR_SEQ_1_2	00111110111	00000000000	00001010000
CLK_COR_SEQ_1_3	00111110111 ⁽⁵⁾	00000000000	00000000000
CLK_COR_SEQ_1_4	00111110111 ⁽⁵⁾	00000000000	00000000000
CLK_COR_SEQ_2_1	00000000000	00000000000	00000000000

Product Not Recommended for New Designs

Table 1-7: Default Attribute Values: GT_AURORA, GT_CUSTOM, GT_ETHERNET (Continued)

Attribute	Default GT_AURORA	Default GT_CUSTOM ⁽¹⁾	Default GT_ETHERNET
CLK_COR_SEQ_2_2	00000000000	00000000000	00000000000
CLK_COR_SEQ_2_3	00000000000	00000000000	00000000000
CLK_COR_SEQ_2_4	00000000000	00000000000	00000000000
CLK_COR_SEQ_2_USE	FALSE	FALSE	FALSE
CLK_COR_SEQ_LEN	4 ⁽⁴⁾	1	2
CLK_CORRECT_USE	TRUE	TRUE	TRUE
COMMA_10B_MASK	1111111111	1111111000	1111111000
CRC_END_OF_PKT	K29_7	K29_7	Note (6)
CRC_FORMAT	USER_MODE	USER_MODE	ETHERNET
CRC_START_OF_PKT	K27_7	K27_7	Note (6)
DEC_MCOMMA_DETECT	TRUE	TRUE	TRUE
DEC_PCOMMA_DETECT	TRUE	TRUE	TRUE
DEC_VALID_COMMA_ONLY	TRUE	TRUE	TRUE
MCOMMA_10B_VALUE	1100000101	1100000000	1100000000
MCOMMA_DETECT	TRUE	TRUE	TRUE
PCOMMA_10B_VALUE	0011111010	0011111000	0011111000
PCOMMA_DETECT	TRUE	TRUE	TRUE
REF_CLK_V_SEL	0	0	0
RX_BUFFER_USE	TRUE	TRUE	TRUE
RX_CRC_USE	FALSE ⁽²⁾	FALSE	FALSE ⁽²⁾
RX_DATA_WIDTH	N ⁽³⁾	2	N ⁽³⁾
RX_DECODE_USE	TRUE	TRUE	TRUE
RX_LOS_INVALID_INCR	1 ⁽²⁾	1	1 ⁽²⁾
RX_LOS_THRESHOLD	4 ⁽²⁾	4	4 ⁽²⁾
RX_LOSS_OF_SYNC_FSM	TRUE ⁽²⁾	TRUE	TRUE ⁽²⁾
SERDES_10B	FALSE ⁽²⁾	FALSE	FALSE ⁽²⁾
TERMINATION_IMP	50 ⁽²⁾	50	50 ⁽²⁾
TX_BUFFER_USE	TRUE	TRUE	TRUE
TX_CRC_FORCE_VALUE	11010110 ⁽²⁾	11010110	11010110 ⁽²⁾
TX_CRC_USE	FALSE ⁽²⁾	FALSE	FALSE ⁽²⁾

Table 1-7: Default Attribute Values: GT_AURORA, GT_CUSTOM, GT_ETHERNET (Continued)

Attribute	Default GT_AURORA	Default GT_CUSTOM ⁽¹⁾	Default GT_ETHERNET
TX_DATA_WIDTH	N ⁽³⁾	2	N ⁽³⁾
TX_DIFF_CTRL	500 ⁽²⁾	500	500 ⁽²⁾
TX_PREEMPHASIS	0 ⁽²⁾	0	0 ⁽²⁾

Notes:

1. All GT_CUSTOM attributes are modifiable.
2. Modifiable attribute for specific primitives.
3. Depends on primitive used: either 1, 2, or 4.
4. Attribute value only when RX_DATA_WIDTH is 4. When RX_DATA_WIDTH is 1 or 2, attribute value is 2.
5. Attribute value only when RX_DATA_WIDTH is 4. When RX_DATA_WIDTH is 1 or 2, attribute value is 0.
6. CRC_EOP and CRC_SOP are not applicable for this primitive.

Table 1-8: Default Attribute Values: GT_FIBRE_CHAN, GT_INFINIBAND, and GT_XAUI

Attribute	Default GT_FIBRE_CHAN	Default GT_INFINIBAND	Default GT_XAUI
ALIGN_COMMA_MSB	FALSE	FALSE	FALSE
CHAN_BOND_LIMIT	1	16	16
CHAN_BOND_MODE	OFF	OFF ⁽¹⁾	OFF ⁽¹⁾
CHAN_BOND_OFFSET	0	8	8
CHAN_BOND_ONE_SHOT	TRUE	FALSE ⁽¹⁾	FALSE ⁽¹⁾
CHAN_BOND_SEQ_1_1	0000000000	00110111100	00101111100
CHAN_BOND_SEQ_1_2	0000000000	Lane ID (Modify with Lane ID)	0000000000
CHAN_BOND_SEQ_1_3	0000000000	00001001010	0000000000
CHAN_BOND_SEQ_1_4	0000000000	00001001010	0000000000
CHAN_BOND_SEQ_2_1	0000000000	00110111100	0000000000
CHAN_BOND_SEQ_2_2	0000000000	Lane ID (Modify with Lane ID)	0000000000
CHAN_BOND_SEQ_2_3	0000000000	00001000101	0000000000
CHAN_BOND_SEQ_2_4	0000000000	00001000101	0000000000
CHAN_BOND_SEQ_2_USE	FALSE	TRUE	FALSE
CHAN_BOND_SEQ_LEN	1	4	1
CHAN_BOND_WAIT	7	8	8
CLK_COR_INSERT_IDLE_FLAG	FALSE ⁽¹⁾	FALSE ⁽¹⁾	FALSE ⁽¹⁾

Product Not Recommended for New Designs

Table 1-8: Default Attribute Values: GT_FIBRE_CHAN, GT_INFINIBAND, and GT_XAUI (Continued)

Attribute	Default GT_FIBRE_CHAN	Default GT_INFINIBAND	Default GT_XAUI
CLK_COR_KEEP_IDLE	FALSE ⁽¹⁾	FALSE ⁽¹⁾	FALSE ⁽¹⁾
CLK_COR_REPEAT_WAIT	2 ⁽¹⁾	1 ⁽¹⁾	1 ⁽¹⁾
CLK_COR_SEQ_1_1	00110111100	00100011100	00100011100
CLK_COR_SEQ_1_2	00010010101	00000000000	00000000000
CLK_COR_SEQ_1_3	00010110101	00000000000	00000000000
CLK_COR_SEQ_1_4	00010110101	00000000000	00000000000
CLK_COR_SEQ_2_1	00000000000	00000000000	00000000000
CLK_COR_SEQ_2_2	00000000000	00000000000	00000000000
CLK_COR_SEQ_2_3	00000000000	00000000000	00000000000
CLK_COR_SEQ_2_4	00000000000	00000000000	00000000000
CLK_COR_SEQ_2_USE	FALSE	FALSE	FALSE
CLK_COR_SEQ_LEN	4	1	1
CLK_CORRECT_USE	TRUE	TRUE	TRUE
COMMA_10B_MASK	1111111000	1111111000	1111111000
CRC_END_OF_PKT	Note (3)	Note (3)	K29_7 ⁽¹⁾
CRC_FORMAT	FIBRE_CHAN	INFINIBAND	USER_MODE ⁽¹⁾
CRC_START_OF_PKT	Note (3)	Note (3)	K27_7 ⁽¹⁾
DEC_MCOMMA_DETECT	TRUE	TRUE	TRUE
DEC_PCOMMA_DETECT	TRUE	TRUE	TRUE
DEC_VALID_COMMA_ONLY	TRUE	TRUE	TRUE
Lane ID(INFINIBAND ONLY)	NA	00000000000 ⁽¹⁾	NA
MCOMMA_10B_VALUE	1100000000	1100000000	1100000000
MCOMMA_DETECT	TRUE	TRUE	TRUE
PCOMMA_10B_VALUE	0011111000	0011111000	0011111000
PCOMMA_DETECT	TRUE	TRUE	TRUE
REF_CLK_V_SEL	0	0	0
RX_BUFFER_USE	TRUE	TRUE	TRUE
RX_CRC_USE	FALSE ⁽¹⁾	FALSE ⁽¹⁾	FALSE ⁽¹⁾
RX_DATA_WIDTH	N ⁽²⁾	N ⁽²⁾	N ⁽²⁾

Table 1-8: Default Attribute Values: GT_FIBRE_CHAN, GT_INFINIBAND, and GT_XAUI (Continued)

Attribute	Default GT_FIBRE_CHAN	Default GT_INFINIBAND	Default GT_XAUI
RX_DECODE_USE	TRUE	TRUE	TRUE
RX_LOS_INVALID_INCR	1 ⁽¹⁾	1 ⁽¹⁾	1 ⁽¹⁾
RX_LOS_THRESHOLD	4 ⁽¹⁾	4 ⁽¹⁾	4 ⁽¹⁾
RX_LOSS_OF_SYNC_FSM	TRUE ⁽¹⁾	TRUE ⁽¹⁾	TRUE ⁽¹⁾
SERDES_10B	FALSE ⁽¹⁾	FALSE ⁽¹⁾	FALSE ⁽¹⁾
TERMINATION_IMP	50 ⁽¹⁾	50 ⁽¹⁾	50 ⁽¹⁾
TX_BUFFER_USE	TRUE	TRUE	TRUE
TX_CRC_FORCE_VALUE	11010110 ⁽¹⁾	11010110 ⁽¹⁾	11010110 ⁽¹⁾
TX_CRC_USE	FALSE ⁽¹⁾	FALSE ⁽¹⁾	FALSE ⁽¹⁾
TX_DATA_WIDTH	N ⁽²⁾	N ⁽²⁾	N ⁽²⁾
TX_DIFF_CTRL	500 ⁽¹⁾	500 ⁽¹⁾	500 ⁽¹⁾
TX_PREEMPHASIS	0 ⁽¹⁾	0 ⁽¹⁾	0 ⁽¹⁾

Notes:

1. Modifiable attribute for specific primitives.
2. Depends on primitive used: either 1, 2, or 4.
3. CRC_EOP and CRC_SOP are not applicable for this primitive.

Byte Mapping

Most of the 4-bit wide status and control buses correlate to a specific byte of TXDATA or RXDATA. This scheme is shown in [Table 1-9](#). This creates a way to tie all the signals together regardless of the data path width needed for the GT_CUSTOM. All other primitives with specific data width paths and all byte-mapped ports are affected by this situation. For example, a 1-byte wide data path has only 1-bit control and status bits (TXKERR[0]) correlating to the data bits TXDATA[7:0]. Footnote 3 in [Table 1-5](#) shows the ports that use byte mapping.

Table 1-9: Control/Status Bus Association to Data Bus Byte Paths

Control/Status Bit	Data Bits
[0]	[7:0]
[1]	[15:8]
[2]	[23:16]
[3]	[31:24]

Digital Design Considerations

Clocking

Clock Signals

There are eight clock inputs into each RocketIO transceiver instantiation ([Table 2-1](#)). REFCLK and BREFCLK are reference clocks generated from an external source and presented to the FPGA as differential inputs. The reference clocks connect to the REFCLK or BREFCLK ports of the RocketIO multi-gigabit transceiver (MGT). While only one of these reference clocks is needed to drive the MGT, BREFCLK or BREFCLK2 must be used for serial speeds of 2.5 Gb/s or greater. (See “[BREFCLK](#),” [page 41](#).)

To clock the serial data, the PLL architecture for the transceiver uses the reference clock as the interpolation source. Removing the reference clock stops the RX and TX PLLs from working. Therefore, a reference clock must be provided at all times. This is especially important at the end of configuration when the PMA portion of the MGT requires a reference clock in order to properly initialize. If a reference clock is not available at this point, the user should toggle the POWERDOWN pin when the reference clock becomes available to ensure the PMA is properly initialized.

The reference clock also clocks a Digital Clock Manager (DCM) or a BUFG to generate all of the other clocks for the MGT. Never run a reference clock through a DCM, since unwanted jitter will be introduced. Any additional jitter on the reference clock will be transferred to the transceiver’s RX and TX serial I/O.

It is recommended that all reference clock sources into the FPGA be LVDS or LVPECL IBUFGDS. The DCI or DT attributes of LVDS are optional. Refer to the [Virtex-II Pro Platform FPGA User Guide](#) (Chapter 3, “Design Considerations”) for a complete listing and discussion of IBUFGDS and other available I/O primitives. Also see section “[Reference Clock](#)” in [Chapter 3](#) of this Guide.

Typically, TXUSRCLK = RXUSRCLK and TXUSRCLK2 = RXUSRCLK2. The transceiver uses one or two clocks generated by the DCM. As an example, USRCLK and USRCLK2 clocks run at the same speed if the 2-byte data path is used. The USRCLK must always be frequency-locked to the reference clock of the RocketIO transceiver when SERDES_10B = FALSE (full-rate operation).

Note: The reference clock must be at least 50 MHz (for full-rate operation only; 60 MHz for half-rate operation) with a duty cycle between 45% and 55%, and should have a frequency stability of

±100 ppm or better, with jitter as low as possible. Module 3 of the Virtex-II Pro data sheet gives further details.

Table 2-1: Clock Ports

Clock	I/Os	Description
BREFCLK	Input	Reference clock used to read the TX FIFO and multiplied by 20 for parallel-to-serial conversion (20X)
BREFCLK2	Input	Alternative to BREFCLK
RXRECCLK	Output	Recovered clock (from serial data stream) divided by 20. Clocks data into the elastic buffer.
REFCLK	Input	Reference clock used to read the TX FIFO and multiplied by 20 for parallel-to-serial conversion (20X)
REFCLK2	Input	Alternative to REFCLK.
REFCLKSEL	Input	Selects which reference clock is used. 0 selects REFCLK; 1 selects REFCLK2.
RXUSRCLK	Input	Clock from FPGA used for reading the RX Elastic Buffer. Clock signals CHBONDI and CHBONDO into and out of the transceiver. This clock is typically the same as TXUSRCLK.
TXUSRCLK ⁽¹⁾	Input	Clock from FPGA used for writing the TX Buffer. This clock must be frequency locked to REFCLK for proper operation.
RXUSRCLK2	Input	Clock from FPGA used to clock RX data and status between the transceiver and FPGA fabric. The relationship between RXUSRCLK2 and RXUSRCLK depends on the width of the receiver data path. RXUSRCLK2 is typically the same as TXUSRCLK2.
TXUSRCLK2 ⁽¹⁾	Input	Clock from FPGA used to clock TX data and status between the transceiver and FPGA fabric. The relationship between TXUSRCLK2 and TXUSRCLK depends on the width of the transmission data path.

Notes:

1. TXUSRCLK and TXUSRCLK2 must be driven by clock sources, even if only the receiver of the MGT is being used.

Table 2-2: Reference Clock Usage

	Data Rate		Routing	
	600 Mb/s – 2.499 Gb/s	2.500 Gb/s – 3.125 Gb/s	Can Route Across Chip?	Can Route Through BUFG?
REFCLK	√		√ ⁽²⁾	√ ⁽²⁾
BREFCLK	√	√	Note (1)	Note (1)

Notes:

1. Because of dedicated routing to reduce jitter, BREFCLK cannot be routed through the fabric.
2. While this option is available in the silicon, this topography adds extra jitter to the reference clock which can affect the overall performance of the transceiver.

BREFCLK

At speeds of 2.5 Gb/s or greater, REFCLK configuration introduces more than the maximum allowable jitter to the RocketIO transceiver. For these higher speeds, BREFCLK configuration is required. The BREFCLK configuration uses dedicated routing resources that reduce jitter.

BREFCLK must enter the FPGA through dedicated clock I/O. BREFCLK can connect to the BREFCLK inputs of the transceiver and the CLKIN input of the DCM for creation of USRCLKs. If all the transceivers on a Virtex-II Pro FPGA are to be used, two BREFCLKs must be created, one for the top of the chip and one for the bottom. These dedicated clocks use the same clock inputs for all packages:

Top	BREFCLK	P	GCLK4S	Bottom	BREFCLK	P	GCLK6P
		N	GCLK5P			N	GCLK7S
	BREFCLK2	P	GCLK2S		BREFCLK2	P	GCLK0P
		N	GCLK3P			N	GCLK1S

An attribute (REF_CLK_V_SEL) and a port (REFCLKSEL) determine which reference clock is used for the MGT PMA block. Figure 2-1 shows how REFCLK and BREFCLK are selected through use of REFCLKSEL and REF_CLK_V_SEL.

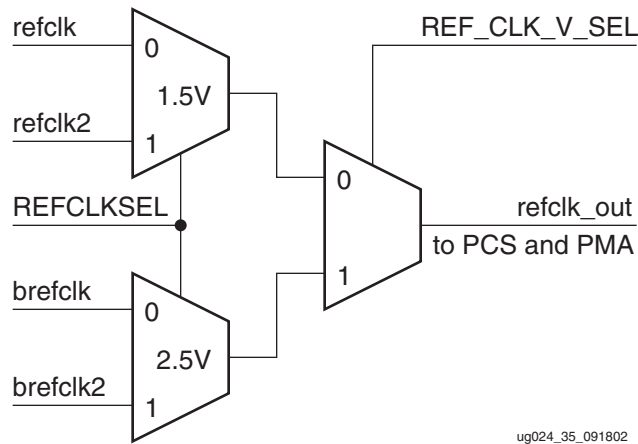

Figure 2-1: REFCLK/BREFCLK Selection Logic

Table 2-3 shows the BREFCLK pin numbers for all packages. Note that these pads must be used for BREFCLK operations.

Table 2-3: BREFCLK Pin Numbers

Package	Top		Bottom	
	BREFCLK Pin Number	BREFCLK2 Pin Number	BREFCLK Pin Number	BREFCLK2 Pin Number
FG256	A8/B8	B9/A9	R8/T8	T9/R9
FG456	C11/D11	D12/C12	W11/Y11	Y12/W12
FG676	B13/C13	C14/B14	AD13/AE13	AE14/AD14

Table 2-3: BREFCLK Pin Numbers

Package	Top		Bottom	
	BREFCLK Pin Number	BREFCLK2 Pin Number	BREFCLK Pin Number	BREFCLK2 Pin Number
FF672	B14/C14	C13/B13	AD14/AE14	AE13/AD13
FF896	F16/G16	G15/F15	AH16/AJ16	AJ15/AH15
FF1152	H18/J18	J17/H17	AK18/AL18	AL17/AK17
FF1148	N/A	N/A	N/A	N/A
FF1517	E20/D20	J20/K20	AR20/AT20	AL20/AK20
FF1704	G22/F22	F21/G21	AU22/AT22	AT21/AU21
FF1696	N/A	N/A	N/A	N/A

Clock Ratio

USRCLK2 clocks the data buffers. The ability to send/receive parallel data to/from the transceiver at three different widths requires the user to change the frequency of USRCLK2. This creates a frequency ratio between USRCLK and USRCLK2. The falling edges of the clocks must align. Table 2-4 shows the ratios for each of the three data widths.

Table 2-4: Data Width Clock Ratios

Data Width	Frequency Ratio of USRCLK/USRCLK2
1 byte	1:2 ⁽¹⁾
2 byte	1:1
4 byte	2:1 ⁽¹⁾

Notes:

1. Each edge of the slower clock must align with the falling edge of the faster clock.

Digital Clock Manager (DCM) Examples

With at least three different clocking schemes possible on the transceiver, a DCM is the best way to create these schemes.

Table 2-5 shows typical DCM connections for several transceiver clocks. REFCLK is the input reference clock for the DCM. The other clocks are generated by the DCM. The DCM establishes a desired phase relationship between TXUSRCLK, TXUSRCLK2, etc. in the FPGA core and REFCLK at the pad.

NOTE: The reference clock may be any of the four MGT clocks, including the BREFCLKs.

Table 2-5: DCM Outputs for Different DATA_WIDTHs

SERDES_10B	TX_DATA_WIDTH RX_DATA_WIDTH	REFCLK	TXUSRCLK RXUSRCLK	TXUSRCLK2 RXUSRCLK2
FALSE	1	CLKIN	CLK0	CLK2X180
FALSE	2	CLKIN	CLK0	CLK0
FALSE	4	CLKIN	CLK180 ⁽¹⁾	CLKDV (divide by 2)
TRUE	1	CLKIN	CLKDV (divide by 2)	CLK180 ⁽¹⁾
TRUE	2	CLKIN	CLKDV (divide by 2)	CLKDV (divide by 2)
TRUE	4	CLKIN	CLKFX180 (divide by 2)	CLKDV (divide by 4)

Notes:

1. Since CLK0 is needed for feedback, it can be used instead of CLK180 to clock USRCLK or USRCLK2 of the transceiver with the use of the transceiver's local inverter, saving a global buffer (BUFG).

Example 1a: Two-Byte Clock with DCM

The following HDL codes are examples of a simple clock scheme using 2-byte data with both USRCLK and USRCLK2 at the same frequency. USRCLK_M is the input for both USRCLK and USRCLK2.

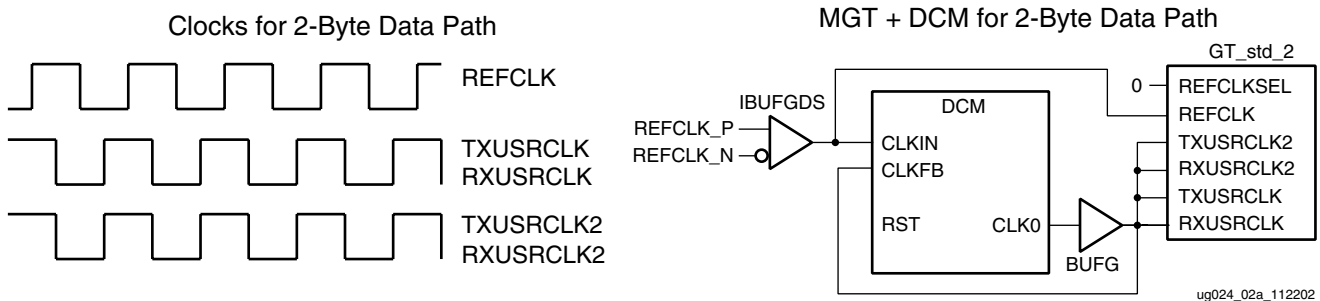

Figure 2-2: Two-Byte Clock with DCM

VHDL Template

```

-- Module:          TWO_BYTE_CLK
-- Description:     VHDL submodule
--                  DCM for 2-byte GT
--
-- Device:          Virtex-II Pro Family
-----
library IEEE;
use IEEE.std_logic_1164.all;
--
-- pragma translate_off
library UNISIM;
use UNISIM.VCOMPONENTS.ALL;
-- pragma translate_on
--
entity TWO_BYTE_CLK is
  port (
    REFCLKIN  : in std_logic;

```

```

        RST      : in std_logic;
        USRCLK_M : buffer std_logic;
        REFCLK   : buffer std_logic;
        LOCK    : out std_logic
    );
end TWO_BYTE_CLK;
--
architecture TWO_BYTE_CLK_arch of TWO_BYTE_CLK is
--
-- Components Declarations:
component BUFG
    port (
        I: in std_logic;
        O : out std_logic
    );
end component;
--
component IBUFG
    port (
        I : in std_logic;
        O : out std_logic
    );
end component;
--
component DCM
    port (
        CLKIN      : in std_logic;
        CLKFB      : in std_logic;
        DSSEN      : in std_logic;
        PSINCDEC   : in std_logic;
        PSEN       : in std_logic;
        PSCLK      : in std_logic;
        RST        : in std_logic;
        CLK0       : out std_logic;
        CLK90      : out std_logic;
        CLK180     : out std_logic;
        CLK270     : out std_logic;
        CLK2X      : out std_logic;
        CLK2X180   : out std_logic;
        CLKDV      : out std_logic;
        CLKFX      : out std_logic;
        CLKFX180   : out std_logic;
        LOCKED     : out std_logic;
        PSDONE     : out std_logic;
        STATUS     : out std_logic_vector ( 7 downto 0 )
    );
end component;
--
-- Signal Declarations:
--
signal GND      : std_logic;
signal CLK0_W   : std_logic;

begin

GND    <= '0';
--
-- DCM Instantiation

```

```

U_DCM: DCM
  port map (
    CLKIN    => REFCLK,
    CLKFB    => USRCLK_M,
    DSSEN    => GND,
    PSINCDEC => GND,
    PSEN     => GND,
    PSCLK    => GND,
    RST      => RST,
    CLK0     => CLK0_W,
    LOCKED   => LOCK
  );

--
-- BUFG Instantiation
U_BUFG: IBUFG
  port map (
    I  => REFCLKIN,
    O  => REFCLK
  );

U2_BUFG: BUFG
  port map (
    I  => CLK0_W,
    O  => USRCLK_M
  );

end TWO_BYTE_CLK_arch;

```

Verilog Template

```

//Module:          TWO_BYTE_CLK
//Description:     Verilog Submodule
//                DCM for 2-byte GT
//
// Device:         Virtex-II Pro Family

module TWO_BYTE_CLK (
    REFCLKIN,
    REFCLK,
    USRCLK_M,
    DCM_LOCKED
);

  input  REFCLKIN;
  output REFCLK;
  output USRCLK_M;
  output DCM_LOCKED;

  wire  REFCLKIN;
  wire  REFCLK;
  wire  USRCLK_M;
  wire  DCM_LOCKED;
  wire  REFCLKINBUF;
  wire  clk_i;

  DCM dcm1 (
    .CLKFB    ( USRCLK_M ),
    .CLKIN    ( REFCLKINBUF ),

```

```

.DSSEN      ( 1'b0 ),
.PSCLK      ( 1'b0 ),
.PSEN       ( 1'b0 ),
.PSINCDEC   ( 1'b0 ),
.RST        ( 1'b0 ),
.CLK0       ( clk_i ),
.CLK90      ( ),
.CLK180     ( ),
.CLK270     ( ),
.CLK2X      ( ),
.CLK2X180   ( ),
.CLKDV      ( ),
.CLKFX      ( ),
.CLKFX180   ( ),
.LOCKED     ( DCM_LOCKED ),
.PSDONE     ( ),
.STATUS     ( )
);

BUFG buf1 (
    .I ( clk_i ),
    .O ( USRCLK_M )
);

IBUFG buf2(
    .I ( REFCLKIN ),
    .O ( REFCLKINBUF )
);

endmodule

```

Example 1b: Two-Byte Clock without DCM

If TXDATA and RXDATA are not clocked off the FPGA using the respective USRCLK2s, then the DCM may be removed from the two-byte clocking scheme, as shown in [Figure 2-3](#):

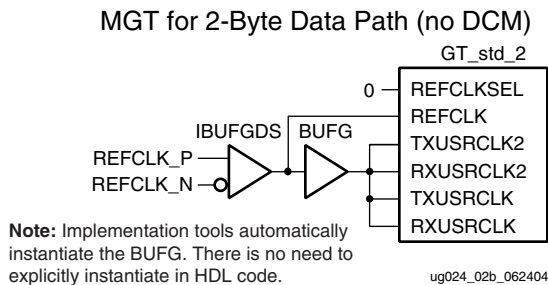

Figure 2-3: Two-Byte Clock without DCM

Example 2: Four-Byte Clock

If a 4-byte or 1-byte data path is chosen, the ratio between USRCLK and USRCLK2 changes. The time it take for the SERDES to serialize the parallel data requires the change in ratios.

The DCM example ([Figure 2-4](#)) is detailed for a 4-byte data path. If 3.125 Gb/s is required, REFCLK is 156 MHz and USRCLK2_M runs at only 78 MHz, including the clocking for

any interface logic. Both USRCLK and USRCLK2 are aligned on the falling edge, since USRCLK_M is 180° out of phase when using local inverters with the transceiver.

Note: These local MGT clock input inverters, shown and noted in Figure 2-4, are *not* included in the FOUR_BYTE_CLK templates.

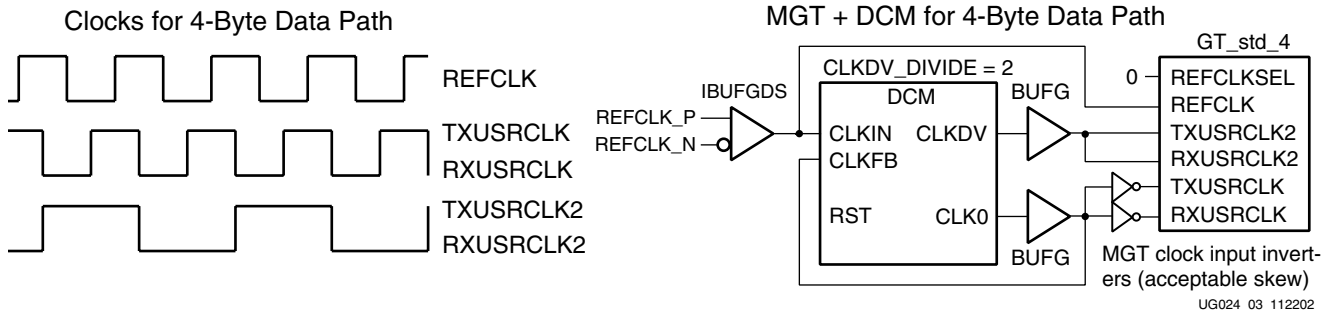

Figure 2-4: Four-Byte Clock

VHDL Template

```

-- Module:          FOUR_BYTE_CLK
-- Description:     VHDL submodule
--                  DCM for 4-byte GT
--
-- Device:          Virtex-II Pro Family
-----
library IEEE;
use IEEE.std_logic_1164.all;
--
-- pragma translate_off
library UNISIM;
use UNISIM.VCOMPONENTS.ALL;
-- pragma translate_on
--
entity FOUR_BYTE_CLK is
  port (
    REFCLKIN      : in std_logic;
    RST           : in std_logic;
    USRCLK_M      : out std_logic;
    USRCLK2_M     : out std_logic;
    REFCLK        : out std_logic;
    LOCK          : out std_logic
  );
end FOUR_BYTE_CLK;
--
architecture FOUR_BYTE_CLK_arch of FOUR_BYTE_CLK is
  --
  -- Components Declarations:
  component BUFG
    port (
      I : in std_logic;
      O : out std_logic
    );
  end component;
  --
  component IBUFG
    port (

```

```

        I : in std_logic;
        O : out std_logic
    );
end component;
--
component DCM
port (
    CLKIN      : in std_logic;
    CLKFB      : in std_logic;
    DSSEN      : in std_logic;
    PSINCDEC   : in std_logic;
    PSEN       : in std_logic;
    PSCLK      : in std_logic;
    RST        : in std_logic;
    CLK0       : out std_logic;
    CLK90      : out std_logic;
    CLK180     : out std_logic;
    CLK270     : out std_logic;
    CLK2X      : out std_logic;
    CLK2X180   : out std_logic;
    CLKDV      : out std_logic;
    CLKFX      : out std_logic;
    CLKFX180   : out std_logic;
    LOCKED     : out std_logic;
    PSDONE     : out std_logic;
    STATUS     : out std_logic_vector ( 7 downto 0 )
);
end component;
--
-- Signal Declarations:
--
signal GND      : std_logic;
signal CLK0_W   : std_logic;
signal CLKDV_W  : std_logic;
signal USRCLK2_M_W: std_logic;

begin
USRCLK2_M <= USRCLK2_M_W;
GND      <= '0';
-- DCM Instantiation
U_DCM: DCM
port map (
    CLKIN      => REFCLK,

    CLKFB      => USRCLK_M,
    DSSEN      => GND,
    PSINCDEC   => GND,
    PSEN       => GND,
    PSCLK      => GND,
    RST        => RST,
    CLK0       => CLK0_W,
    CLKDV      => CLKDV_W,
    LOCKED     => LOCK

);

-- BUFG Instantiation
U_BUFG: IBUFG
port map (
    I => REFCLKIN,

```



```

        O => REFCLK
    );

    U2_BUF: BUF
    port map (
        I => CLK0_W,
        O => USRCLK_M
    );

    U3_BUF: BUF
    port map (
        I => CLKDV_W,
        O => USRCLK2_M_W
    );

end FOUR_BYTE_CLK_arch;

```

Verilog Template

```

// Module:          FOUR_BYTE_CLK
// Description:     Verilog Submodule
//                 DCM for 4-byte GT
//
// Device:         Virtex-II Pro Family

module FOUR_BYTE_CLK(
    REFCLKIN,
    REFCLK,
    USRCLK_M,
    USRCLK2_M,
    DCM_LOCKED
);

    input    REFCLKIN;
    output   REFCLK;
    output   USRCLK_M;
    output   USRCLK2_M;
    output   DCM_LOCKED;

    wire     REFCLKIN;
    wire     REFCLK;
    wire     USRCLK_M;
    wire     USRCLK2_M;
    wire     DCM_LOCKED;
    wire     REFCLKINBUF;
    wire     clkdv2;
    wire     clk_i;

    DCM dcm1 (
        .CLKFB      ( USRCLK_M ),
        .CLKIN      ( REFCLKINBUF ) ,
        .DSSEN      ( 1'b0 ),
        .PSCLK      ( 1'b0 ),
        .PSEN       ( 1'b0 ),
        .PSINCDEC   ( 1'b0 ),
        .RST        ( 1'b0 ),
        .CLK0       ( clk_i ),
        .CLK90      ( ),

```

```

        .CLK180      ( ),
        .CLK270      ( ),
        .CLK2X       ( ),
        .CLK2X180    ( ),
        .CLKDV       ( clkdv2 ),
        .CLKFX       ( ),
        .CLKFX180    ( ),
        .LOCKED      ( DCM_LOCKED ),
        .PSDONE      ( ),
        .STATUS      ( )
    );

    BUFG buf1 (
        .I ( clkdv2 ),
        .O ( USRCLK2_M )
    );

    BUFG buf2 (
        .I ( clk_i ),
        .O ( USRCLK_M )
    );

    IBUFG buf3 (
        .I ( REFCLKIN ),
        .O ( REFCLKINBUF )
    );

endmodule

```

Example 3: One-Byte Clock

This is the 1-byte data path width clocking scheme example. USRCLK2_M is twice as fast as USRCLK_M. It is also phase-shifted 180° for falling edge alignment.

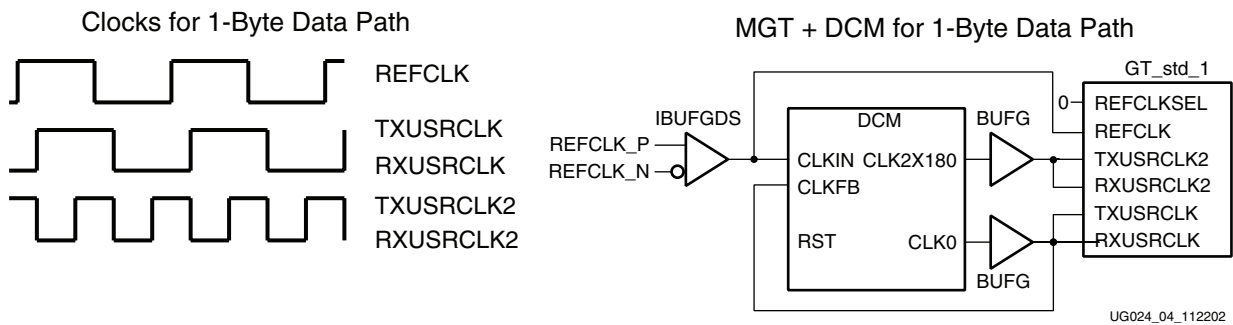

Figure 2-5: One-Byte Clock

VHDL Template

```

-- Module:          ONE_BYTE_CLK
-- Description:     VHDL submodule
--                 DCM for 1-byte GT
--
-- Device:         Virtex-II Pro Family
-----
library IEEE;
use IEEE.std_logic_1164.all;

```

```

--
-- pragma translate_off
library UNISIM;
use UNISIM.VCOMPONENTS.ALL;
-- pragma translate_on
--
entity ONE_BYTE_CLK is
  port (
    REFCLKIN      : in std_logic;
    RST           : in std_logic;
    USRCLK_M      : out std_logic;
    USRCLK2_M     : out std_logic;
    REFCLK        : out std_logic;
    LOCK         : out std_logic
  );
end ONE_BYTE_CLK;
--
architecture ONE_BYTE_CLK_arch of ONE_BYTE_CLK is
--
-- Components Declarations:
component BUFG
  port (
    I  : in std_logic;
    O  : out std_logic
  );
end component;
--
component IBUFG
  port (
    I  : in std_logic;
    O  : out std_logic
  );
end component;
--
component DCM
  port (
    CLKIN      : in std_logic;
    CLKFB      : in std_logic;
    DSSEN      : in std_logic;
    PSINCDEC   : in std_logic;
    PSEN       : in std_logic;
    PSCLK      : in std_logic;
    RST        : in std_logic;
    CLK0       : out std_logic;
    CLK90      : out std_logic;
    CLK180     : out std_logic;
    CLK270     : out std_logic;
    CLK2X      : out std_logic;
    CLK2X180   : out std_logic;
    CLKDV      : out std_logic;
    CLKFX      : out std_logic;
    CLKFX180   : out std_logic;
    LOCKED     : out std_logic;
    PSDONE     : out std_logic;
    STATUS     : out std_logic_vector ( 7 downto 0 )
  );
end component;
--
-- Signal Declarations:

```

```

--
signal GND          : std_logic;
signal CLK0_W       : std_logic;
signal CLK2X180_W  : std_logic;
signal USRCLK2_M_W : std_logic;
signal USRCLK_M_W  : std_logic;

begin

GND          <= '0';
USRCLK2_M <= USRCLK2_M_W;
USRCLK_M   <= USRCLK_M_W;
--
-- DCM Instantiation
U_DCM: DCM
  port map (
    CLKIN      => REFCLK,

    CLKFB      => USRCLK_M,
    DSSEN      => GND,
    PSINCDEC   => GND,
    PSEN       => GND,
    PSCLK      => GND,
    RST        => RST,
    CLK0       => CLK0_W,
    CLK2X180   => CLK2X180_W,
    LOCKED     => LOCK
  );
-- BUFG Instantiation
U_BUF1: IBUFG
  port map (
    I => REFCLKIN,
    O => REFCLK
  );

U2_BUF2: BUFG
  port map (
    I => CLK0_W,
    O => USRCLK_M_W
  );

U4_BUF4: BUFG
  port map (
    I => CLK2X180_W,
    O => USRCLK2_M_W
  );

end ONE_BYTE_CLK_arch;

```

Verilog Template

```

// Module:      ONE_BYTE_CLK
// Description:  Verilog Submodule
//              DCM for 1-byte GT
// Device:      Virtex-II Pro Family
module ONE_BYTE_CLK (
    REFCLKIN,
    REFCLK,

```

```

        USRCLK_M,
        USRCLK2_M,
        DCM_LOCKED
    );

    input  REFCLKIN;
    output REFCLK;
    output USRCLK_M;
    output USRCLK2_M;
    output DCM_LOCKED;

    wire  REFCLKIN;
    wire  REFCLK;
    wire  USRCLK_M;
    wire  USRCLK2_M;
    wire  DCM_LOCKED;
    wire  REFCLKINBUF;
    wire  clk_i;
    wire  clk_2x_180;

    DCM dcm1 (
        .CLKFB      ( USRCLK_M ),
        .CLKIN      ( REFCLKINBUF ),

        .DSSEN      ( 1'b0 ),
        .PCLK       ( 1'b0 ),
        .PSEN       ( 1'b0 ),
        .PSINCDEC   ( 1'b0 ),
        .RST        ( 1'b0 ),
        .CLK0       ( clk_i ),
        .CLK90      ( ),
        .CLK180     ( ),
        .CLK270     ( ),
        .CLK2X      ( ),
        .CLK2X180   ( clk2x_180 ),
        .CLKDV      ( ),
        .CLKFX      ( ),
        .CLKFX180   ( ),
        .LOCKED     ( DCM_LOCKED ),
        .PSDONE     ( ),
        .STATUS     ( )
    );

    BUFG buf1 (
        .I ( clk2x_180 ),
        .O ( USRCLK2_M )
    );

    BUFG buf2 (
        .I ( clk_i ),
        .O ( USRCLK_M )
    );

    IBUFGbuf3 (
        .I ( REFCLKIN ),
        .O ( REFCLKINBUF )
    );

endmodule

```

Half-Rate Clocking Scheme

Some applications require serial speeds between 600 Mb/s and 1 Gb/s. (Refer to [XAPP572](#) when considering running in this serial range.) The transceiver attribute `SERDES_10B`, which sets the `REFCLK` multiplier to 10 instead of 20, enables the half-rate speed range when set to `TRUE`. With this configuration, the clocking scheme also changes. The figures below illustrate the three clocking scheme waveforms when `SERDES_10B = TRUE`.

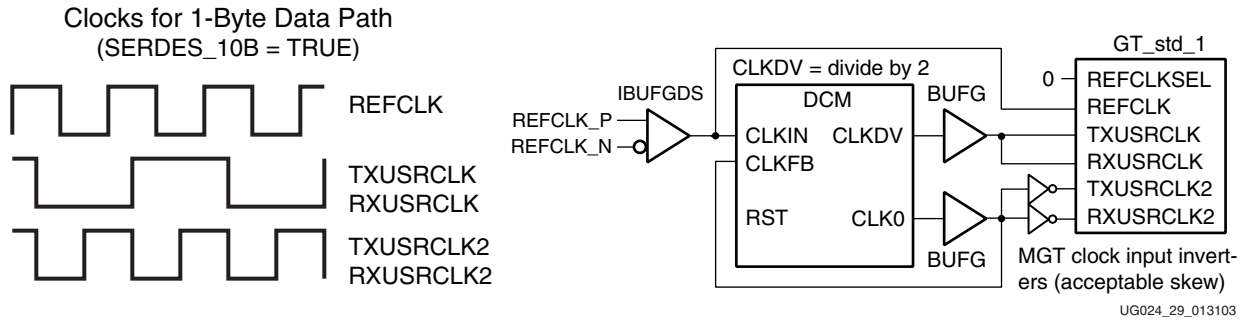

Figure 2-6: One-Byte Data Path Clocks, `SERDES_10B = TRUE`

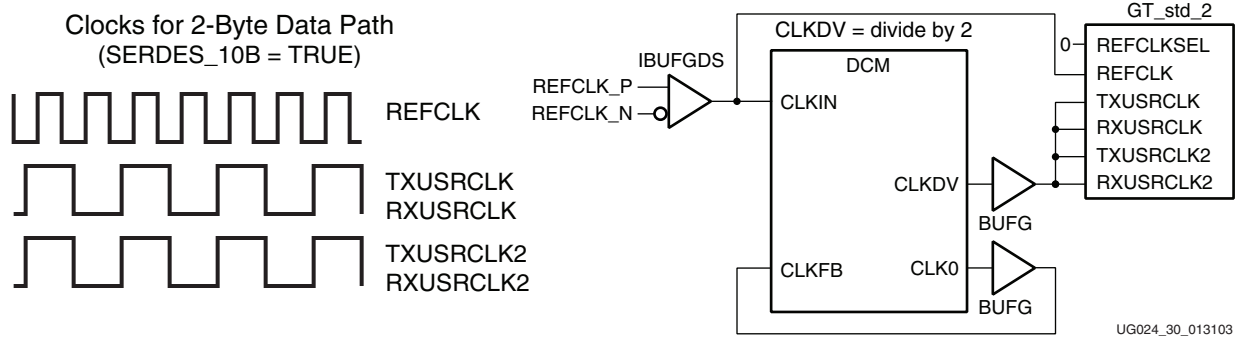

Figure 2-7: Two-Byte Data Path Clocks, `SERDES_10B = TRUE`

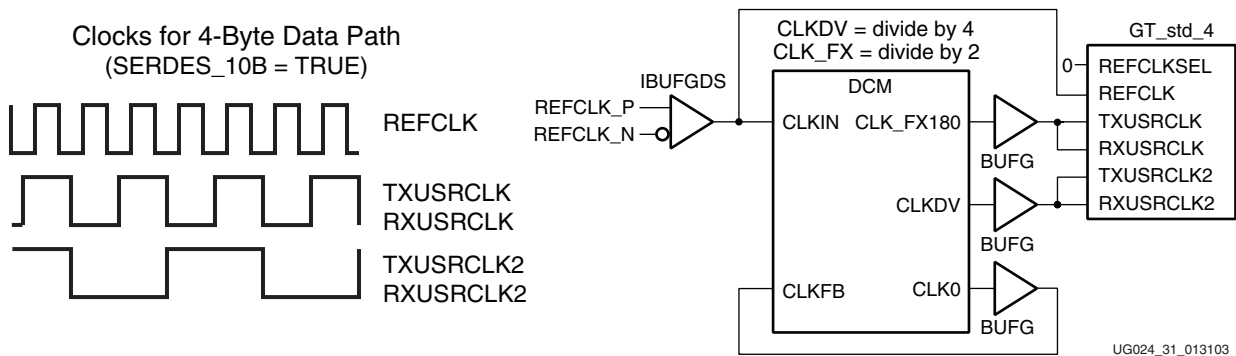

Figure 2-8: Four-Byte Data Path Clocks, `SERDES_10B = TRUE`

Multiplexed Clocking Scheme *with* DCM

Following configuration of the FPGA, some applications might need to change the frequency of its REFCLK depending on the protocol used. Figure 2-9 shows how the design can use two different reference clocks connected to two different DCMs. The clocks are then multiplexed before input into the RocketIO transceiver.

User logic can be designed to determine during auto negotiation if the reference clock used for the transceiver is incorrect. If so, the transceiver must then be reset and another reference clock selected.

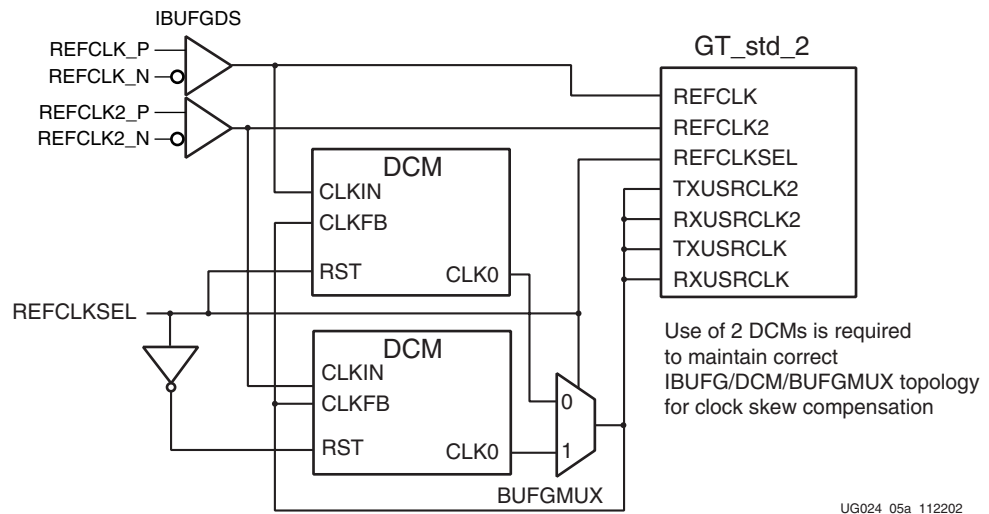

Figure 2-9: Multiplexed REFCLK with DCM

Multiplexed Clocking Scheme *without* DCM

As with “Example 1b: Two-Byte Clock without DCM”, the DCMs shown in Figure 2-9 may be removed if TXDATA and RXDATA are not clocked off the FPGA. (See Figure 2-10.) However, the transceiver must still be reset when clocks are switched.

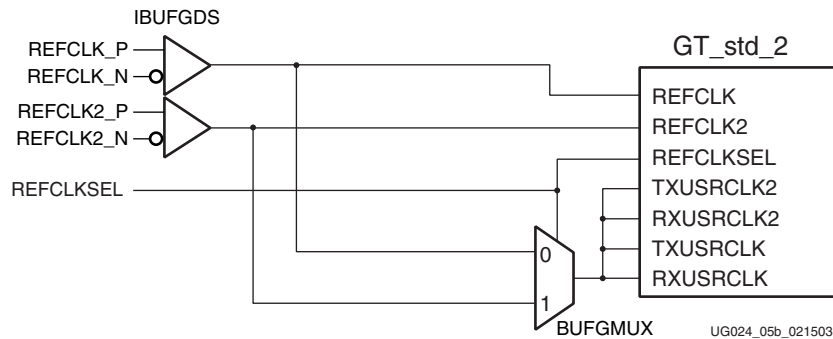

Figure 2-10: Multiplexed REFCLK without DCM

RXRECCLK

RXRECCLK is a recovered clock derived by dividing by 20 the received data stream bit rate (whether full-rate or half-rate). If clock correction is bypassed, it is not possible to compensate for differences in the clock embedded in the received data and the REFCLK-created USRCLKs. In this case, RXRECCLK is used to generate the RXUSRCLKs, as shown in Figure 2-11.

RXRECCLK changes monotonically when it changes from being locked to the reference clock to being locked to data and vice versa. The recovered bit clock jumps by a maximum of 1/16th of a bit period every eight RXRECCLK cycles (20 ps for a data rate of 3.125 Gb/s with a 320-ps bit period) in the interpolator. RXRECCLK is derived from this bit clock through a divide-by-20 process. When the data input is kept static, however, the recovered clock does not frequency-lock to the reference clock exactly, but can deviate from it by up to 400 ppm.

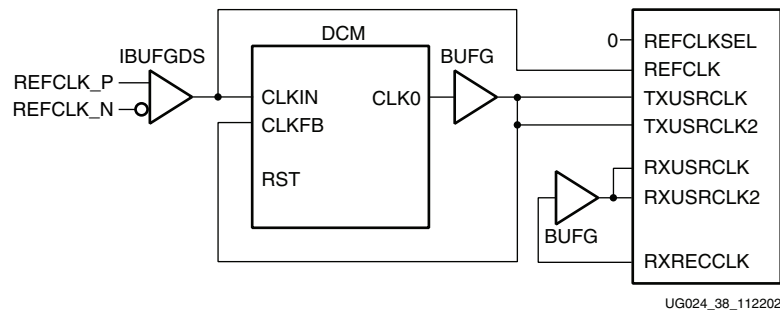

Figure 2-11: Using RXRECCLK to Generate RXUSRCLK and RXUSRCLK2

Note: Bypassing the RX elastic buffer is not recommended, as the skew created by the DCM and routing to global clock resources is uncertain and may cause unreliable performance.

Clock Dependency

All signals used by the FPGA fabric to interact between user logic and the transceiver depend on an edge of USRCLK2. These signals all have setup and hold times with respect to this clock. For specific timing values, see Module 3 of the Virtex-II Pro data sheet. The timing relationships are further discussed and illustrated in Appendix A, “RocketIO Transceiver Timing Model.”

Data Path Latency

With the many configurations of the MGT, the both transmit and receive data path latencies vary. Below are several tables that provide approximate latencies for common configurations.

Table 2-6: Latency through Various Transmitter Components/Processes

Component/Process		Latency		
TX Fabric/GT Interface		1 Byte Data Path: 2.5 TXUSRCLK2 cycles 1.25 TXUSRCLK cycles	2 Byte Data Path: 1 TXUSRCLK2 cycle 1 TXUSRCLK cycle	4 Byte Data Path: 1.25 TXUSRCLK2 cycles 2.5 TXUSRCLK cycles
TX CRC	included	7 TXUSRCLK cycles		
	bypassed	1 TXUSRCLK cycle		
8B/10B Encoder	included	1 TXUSRCLK cycle		
	bypassed	1 TXUSRCLK cycle		
TX FIFO		4 TXUSRCLK cycles (± 0.5)		
TX SERDES		SERDES_10B = FALSE: 1.5 TXUSRCLK cycles	SERDES_10B = TRUE: 0.5 TXUSRCLK cycles (approx.)	

Table 2-7: Latency through Various Receiver Components/Processes

Component/Process		Latency		
RX SERDES		1.5 recovered clock (RXRECCLK) cycles		
Comma Detect/Realignment		2.5 or 3.5 recovered clock cycles (some bits bypass one register, depending on comma alignment)		
8B/10B Decoder	included	1 recovered clock cycle		
	bypassed	1 recovered clock cycle		
RX FIFO		18 RXUSRCLK cycles (± 0.5)		
RX GT/Fabric Interface		1 Byte Data Path: 2.5 RXUSRCLK2 cycles 1.25 RXUSRCLK cycles	2 Byte Data Path: 1 RXUSRCLK2 cycle 1 RXUSRCLK cycle	4 Byte Data Path: 1.25 RXUSRCLK2 cycles 2.5 RXUSRCLK cycles

Reset/Power Down

The receiver and transmitter have their own synchronous reset inputs. The transmitter reset recenters the transmission FIFO, and resets all transmitter registers and the 8B/10B encoder. The receiver reset recenters the receiver elastic buffer, and resets all receiver registers and the 8B/10B decoder. Neither reset signal has any effect on the PLLs.

After the DCM-locked signal is asserted, the resets can be asserted. The resets must be asserted for two USRCLK2 cycles to ensure correct initialization of the FIFOs. Although both the transmit and receive resets can be attached to the same signal, separate signals are preferred. This allows the elastic buffer to be cleared in case of an over/underflow without affecting the ongoing TX transmission. The following example is an implementation that resets all three data-width transceivers.

Additional reset and power control descriptions are given in [Table 2-8](#) and [Table 2-9](#).

Table 2-8: Reset and Power Control Descriptions

Ports	Description
RXRESET	Synchronous receive system reset recenters the receiver elastic buffer, and resets the 8B/10B decoder, comma detect, channel bonding, clock correction logic, and other receiver registers. The PLL is unaffected.
TXRESET	Synchronous transmit system reset recenters the transmission FIFO, and resets the 8B/10B encoder and other transmission registers. The PLL is unaffected.
POWERDOWN	Shuts down the transceiver (both RX and TX sides). In POWERDOWN mode, transmit output pins TXP/TXN are not driven, but biased by the state of transmit termination supply VTTX. If VTTX is not powered, TXP/TXN float to a high-impedance state. Receive input pins RXP/RXN respond similarly to the state of receive termination supply VTRX.

Table 2-9: Power Control Descriptions

POWERDOWN	Transceiver Status
0	Transceiver in operation
1	Transceiver temporarily powered down

Notes:

- Unused transceivers are automatically configured as powered-down by the implementation tools.

VHDL Template

```

-- Module: gt_reset
-- Description: VHDL submodule
-- reset for GT
--
-- Device: Virtex-II Pro Family
-----
LIBRARY IEEE;
USE IEEE.std_logic_1164.all;
use IEEE.STD_LOGIC_ARITH.ALL;
use IEEE.Numeric_STD.all;
use IEEE.STD_LOGIC_UNSIGNED.ALL;
--
-- pragma translate_off
library UNISIM;
use UNISIM.VCOMPONENTS.ALL;
-- pragma translate_on
--
entity gt_reset is
port (
USRCLK2_M : in std_logic;
LOCK      : in std_logic;
REFCLK    : out std_logic;
DCM_LOCKED: in std_logic;
RST       : out std_logic);
end gt_reset;
--
architecture RTL of gt_reset is
--
    signal startup_count : std_logic_vector (7 downto 0);
begin

```

```
process (USRCLK2_M, DCM_LOCKED)

begin
  if (USRCLK2_M' event and USRCLK2_M = '1') then
    if (DCM_LOCKED = '0') then
      startup_count <= "00000000";
    elsif (DCM_LOCKED = '1') then
      startup_count <= startup_count + "00000001";
    end if;
  end if;

  if (USRCLK2_M' event and USRCLK2_M = '1') then
    if (DCM_LOCKED = '0') then
      RST <= '1';
    elsif (startup_count = "00000010") then
      RST <= '0';
    end if;
  end if;

end process;

end RTL;
```

Verilog Template

```
// Module:      gt_reset
// Description: Verilog Submodule
//              reset for4-byte GT
//
// Device:      Virtex-II Pro Family

module gt_reset(
    USRCLK2_M,
    DCM_LOCKED,
    RST
);

input    USRCLK2_M;
input    DCM_LOCKED;
output   RST;

wire     USRCLK2_M;
wire     DCM_LOCKED;
reg      RST;
reg [7:0] startup_counter;

always @ ( posedge USRCLK2_M )
    if ( !DCM_LOCKED )
        startup_counter <= 8'h0;
    else if ( startup_counter != 8'h02 )
        startup_counter <= startup_counter + 1;

always @ ( posedge USRCLK2_M or negedge DCM_LOCKED )
    if ( !DCM_LOCKED )
        RST <= 1'b1;
    else
        RST <= ( startup_counter != 8'h02 );

endmodule
```

8B/10B Encoding/Decoding

Overview

The RocketIO transceiver has the ability to encode eight bits into a 10-bit serial stream using standard 8B/10B encoding. This guarantees a DC-balanced, edge-rich serial stream, facilitating DC- or AC-coupling and clock recovery. [Table 2-10, page 62](#), shows the significance of 8B/10B ports that change purpose, depending on whether 8B/10B is bypassed or enabled.

8B/10B Encoder

A bypassable 8B/10B encoder is included in the transmitter. The encoder uses the same 256 data characters and 12 control characters (shown in [Appendix B, “8B/10B Valid Characters”](#)) that are used for Gigabit Ethernet, XAUI, Fibre Channel, and InfiniBand.

The encoder accepts 8 bits of data along with a K-character signal for a total of 9 bits per character applied. If the K-character signal is High, the data is encoded into one of the twelve possible K-characters available in the 8B/10B code. (See [Table B-2, page 143](#).) If the K-character input is Low, the 8 bits are encoded as standard data. If the K-character input is High and a user applies other than one of the twelve possible combinations, TXKERR indicates the error.

8B/10B Decoder

An optional 8B/10B decoder is included in the receiver. A programmable option allows the decoder to be bypassed. When it is bypassed, the 10-bit character order is as shown in [Figure 2-14, page 65](#). The decoder uses the same table that is used for Gigabit Ethernet, Fibre Channel, and InfiniBand.

The decoder separately detects both “disparity errors” and “out-of-band” errors. A *disparity error* occurs when a 10-bit character is received that exists within the 8B/10B table ([Table B-1, page 135](#)), but has an incorrect disparity. An *out-of-band error* occurs when a 10-bit character is received that does not exist within the 8B/10B table. It is possible to obtain an out-of-band error without having a disparity error. The proper disparity is always computed for both legal and illegal characters. The current running disparity is available at the RXRUNDISP signal.

The 8B/10B decoder performs a unique operation if out-of-band data is detected. Should this occur, the decoder signals the error, passes the illegal 10 bits through, and places them on the outputs. This can be used for debugging purposes if desired.

The decoder also signals reception of one of the twelve valid K-characters ([Table B-2, page 143](#)) by way of the RXCHARISK port.

In addition, a programmable comma detect is included. The comma detect signal RXCOMMADET registers a comma on the receipt of any plus-comma, minus-comma, or both. Since the comma is defined as a 7-bit character, this includes several out-of-band characters. RXCHARISCOMMA allows the decoder to detect only the three defined commas (K28.1, K28.5, and K28.7) as plus-comma, minus-comma, or both. In total, there are six possible options, three for valid commas and three for “any comma.”

Note that all bytes (1, 2, or 4) at the RX FPGA interface each have their own individual 8B/10B indicators (K-character, disparity error, out-of-band error, current running disparity, and comma detect).

Ports and Attributes

TXBYPASS8B10B, RX_DECODE_USE

One port and one attribute enable 8B/10B encoding/decoding in the transceiver.

TXBYPASS8B10B is a byte-mapped port that is 1, 2, or 4 bits wide, depending on the data width of the transceiver primitive being used. These bits correlate to each byte of the data path. To enable 8B/10B encoding in the transmitter, these bits must be set Low. In this mode, the transmit data input to the TXDATA port is non-encoded data of either 8, 16, or 32 bits wide. However, if other encoding schemes are preferred, the encoder capabilities can be bypassed by setting all bits High. In this mode, the data input to TXDATA is either 10, 20, or 40 bits wide. The extra bits are fed through the TXCHARDISPMODE and TXCHARDISPVAL buses (shown in Table 2-10).

The decoder is controlled by the attribute RX_DECODE_USE. When this attribute is set to TRUE, the decoder is enabled and should coincide with TXBYPASS8B10B being set Low. In this mode, the received data output from the RXDATA port is decoded data, either 8, 16, or 32 bits wide. However, when the attribute is set to FALSE, the decoder is disabled. In this mode, the received data is 10, 20, or 40 bits wide, and the extra bits are provided by RXCHARISK and RXRUNDISP (shown in Table 2-10).

If this pair is not matched, the data is not received correctly. Figure 2-12 shows the encoding/decoding blocks of the transceiver and how the data passes through these blocks. Table 2-10 shows the significance of 8B/10B ports that change purpose depending on whether 8B/10B is bypassed or enabled.

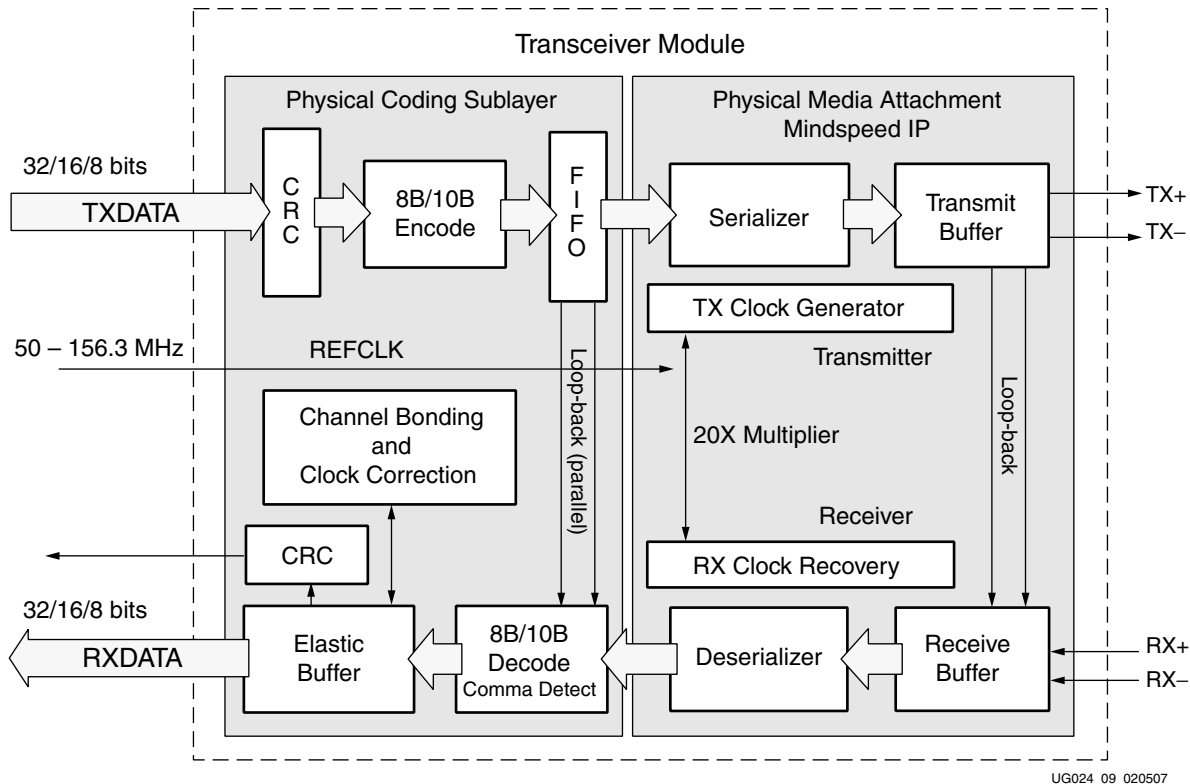

Figure 2-12: 8B/10B Data Flow

Table 2-10: 8B/10B Bypassed Signal Significance

		Function	
TXBYPASS8B10B	0	8B/10B encoding is enabled (not bypassed). 1, 2, or 4 bits, mapped to number of bytes of data path width.	
	1	8B/10B encoding bypassed (disabled). 1, 2, or 4 bits, mapped to number of bytes of data path width.	
		Function, 8B/10B Enabled	Function, 8B/10B Bypassed
TXCHARDISPMODE, TXCHARDISPVAL	00	Maintain running disparity normally	Part of 10-bit encoded byte (see Figure 2-13): TXCHARDISPMODE[0] (or: [1] / [2] / [3]) TXCHARDISPVAL[0] (or: [1] / [2] / [3]) TXDATA[7:0] (or: [15:8] / [23:16] / [31:24])
	01	Invert the normally generated running disparity before encoding this byte.	
	10	Set negative running disparity before encoding this byte.	
	11	Set positive running disparity before encoding this byte.	
RXCHARISK	Received byte is a K-character		Part of 10-bit encoded byte (see Figure 2-14): RXCHARISK[0] (or: [1] / [2] / [3]) RXRUNDISP[0] (or: [1] / [2] / [3]) RXDATA[7:0] (or: [15:8] / [23:16] / [31:24])
RXRUNDISP	0	Indicates running disparity is NEGATIVE	
	1	Indicates running disparity is POSITIVE	
RXDISPERR	Disparity error occurred on current byte		Unused
TXCHARISK	Transmitted byte is a K-character		Unused
RXCHARISCOMMA	Received byte is a comma		Unused

TXCHARDISPVAL, TXCHARDISPMODE

TXCHARDISPVAL and TXCHARDISPMODE are dual-purpose ports for the transmitter depending upon whether 8B/10B encoding is enabled. [Table 2-10](#) shows this dual functionality. When encoding is enabled, these ports function as byte-mapped control ports controlling the running disparity of the transmitted serial data.

In the encoding configuration, the disparity of the serial transmission can be controlled with the TXCHARDISPVAL and TXCHARDISPMODE ports. When TXCHARDISPMODE is set High, the running disparity is set *before* encoding the specific byte. TXCHARDISPVAL determines if the disparity is negative (set Low) or positive (set High). [Table 2-11](#) illustrates this.

Table 2-11: Running Disparity Control

{TXCHARDISPMODE, TXCHARDISPVAL}	Function
00	Maintain running disparity normally
01	Invert normally generated running disparity before encoding this byte
10	Set negative running disparity before encoding this byte
11	Set positive running disparity before encoding this byte

When TXCHARDISPMODE is set Low, the running disparity is maintained if TXCHARDISPVAL is also set Low, but the disparity is inverted before encoding the byte when TXCAHRDISPVAL is set High.

Most applications will use the mode where both TXCHARDISPMODE and TXCHARDISPVAL are set Low. Some applications may use other settings if special running disparity configurations are required, such as in the [“Vitesse Disparity Example”](#) below.

In the bypassed configuration, TXCHARDISPMODE [0] becomes bit 9 of the 10 bits of encoded data. TXCHARDISPMODE [1:3] are bits 19, 29, and 39 in the 20- and 40-bit wide buses. TXCHARDISPVAL becomes bits 8, 18, 28, and 38 of the transmit data. See [Figure 2-13](#).

TXCHARISK

TXCHARISK is a byte-mapped control port that is used only when the 8B/10B encoder is implemented. This port controls whether the byte of TXDATA is to be encoded as a control (K) character (when asserted High) or as a data character (when de-asserted). When 8B/10B encoding is bypassed, this port is undefined.

TXRUNDISP

TXRUNDISP is a status port that is byte-mapped to TXDATA. This port indicates the running disparity after the byte of TXDATA is encoded. When High, the disparity is positive. When Low, the disparity is negative.

TXKERR

TXKERR is a status port that is byte-mapped to TXDATA. This port is defined only if 8B/10B encoding is enabled. If a bit is asserted High, it means that TXDATA and TXCHARISK have combined to create an invalid control (K) character. The transmission, reception, and decode of this invalid character will create unexpected RXDATA results in the RocketIO receiver, or in other transceivers.

RXCHARISK, RXRUNDISP

RXCHARISK and RXRUNDISP are dual-purpose ports for the receiver depending whether 8B/10B decoding is enabled. [Table 2-10](#) shows this dual functionality. When decoding is enabled, the ports function as byte-mapped status ports for the received data.

In the 8B/10B decoding configuration, RXCHARISK asserted High indicates the received byte of data is a control (K) character. Otherwise, the received byte of data is a data character. See [Appendix B, “8B/10B Valid Characters”](#).

The RXRUNDISP port indicates the disparity of the received byte is either negative or positive. RXRUNDISP asserted High indicates positive disparity. This is used in cases like the [“Vitesse Disparity Example”](#) below. When CLK_COR_INSERT_IDLE_FLAG = TRUE, RXRUNDISP is asserted to flag the presence of an inserted clock correction sequence.

In the bypassed configuration, RXCHARISK and RXRUNDISP are additional data bits for the 10-, 20-, or 40-bit buses, similar to the configuration on the transmit side. RXCHARISK [0:3] relates to bits 9, 19, 29, and 39, while RXRUNDISP pertains to bits 8, 18, 28, and 38 of the data bus. See [Figure 2-14](#).

RXDISPERR

RXDISPERR is a status port for the receiver that is byte-mapped to RXDATA. When a bit in RXDISPERR is asserted High, it means that a disparity error has occurred in the received data. This usually indicates data corruption (bit errors) or transmission of an invalid control character. It can also occur in cases where normal disparity is not required, such as in the [“Vitesse Disparity Example”](#).

RXNOTINTABLE

RXNOTINTABLE is a status port for the receiver that is byte-mapped to RXDATA. When it is asserted High, it means that the received data is not in the 8B/10B tables. This port is only used when the 8B/10B decoder is enabled.

Vitesse Disparity Example

To support other protocols, the transceiver can affect the disparity mode of the serial data transmitted. For example, Vitesse channel-to-channel alignment protocol sends out:

K28.5+ K28.5+ K28.5- K28.5- or K28.5- K28.5- K28.5+ K28.5+

instead of:

K28.5+ K28.5- K28.5+ K28.5- or K28.5- K28.5+ K28.5- K28.5+

The logic must assert TXCHARDISPVAL to cause the serial data to send out two negative running disparity characters.

Note: If bypassing 8B/10B encoding/decoding, the remaining 10 bits will be the 10-bit-encoded version of the channel bonding sequence. This is the same as the clock correction sequence shown in [Table 2-15, page 74](#).

Transmitting Vitesse Channel Bonding Sequence

```

TXBYPASS8B10B
| TXCHARISK
| | TXCHARDISPMODE
| | | TXCHARDISPVAL
| | | | TXDATA
| | | | |
0 1 0 0 10111100 K28.5+ (or K28.5-)
0 1 0 1 10111100 K28.5+ (or K28.5-)
0 1 0 0 10111100 K28.5- (or K28.5+)
0 1 0 1 10111100 K28.5- (or K28.5+)
    
```

The RocketIO core receives this data, but for cases where TXCHARDISPVAL is set High during data transmission, the `disp_err` bit in `CHAN_BOND_SEQ` must also be set High.

Receiving Vitesse Channel Bonding Sequence

On the RX side, the definition of the channel bonding sequence uses the `disp_err` bit to specify the flipped disparity.

```

                                10-bit literal value
                                | disp_err
                                | | char_is_k
                                | | | 8-bit_byte_value
                                | | | |
CHAN_BOND_SEQ_1_1 = 0 0 1 10111100 matches K28.5+ (or K28.5-)
CHAN_BOND_SEQ_1_2 = 0 1 1 10111100 matches K28.5+ (or K28.5-)
CHAN_BOND_SEQ_1_3 = 0 0 1 10111100 matches K28.5- (or K28.5+)
CHAN_BOND_SEQ_1_4 = 0 1 1 10111100 matches K28.5- (or K28.5+)
CHAN_BOND_SEQ_LEN = 4
CHAN_BOND_SEQ_2_USE = FALSE
    
```

8B/10B Bypass Serial Output

When 8B/10B encoding is bypassed, the TXCHARDISPVAL and TXCHARDISPMODE bits become bits “b” and “a”, respectively, of the 10-bit encoded data that the transceiver must transmit to the receiving terminal. Figure 2-13 illustrates the TX data map during 8B/10B bypass.

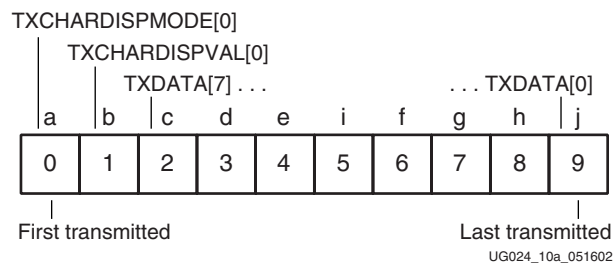

Figure 2-13: 10-Bit TX Data Map with 8B/10B Bypassed

During receive when 8B/10B decoding is enabled, the running disparity of the serial transmission can be read by the transceiver from the RXRUNDISP port, while the RXCHARISK port indicates presence of a K-character. When 8B/10B decoding is bypassed, these bits remain as Bits “b” and “a”, respectively, of the 10-bit encoded data that the transceiver passes on to the user logic. Figure 2-14 illustrates the RX data map during 8B/10B bypass.

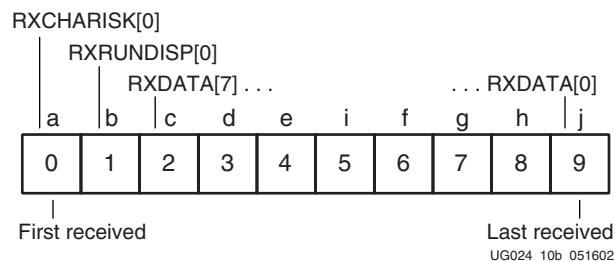

Figure 2-14: 10-Bit RX Data Map with 8B/10B Bypassed

8B/10B Serial Output Format

The 8B/10B encoding translates a 8-bit parallel data byte to be transmitted into a 10-bit serial data stream. This conversion and data alignment are shown in Figure 2-15. The serial port transmits the least significant bit of the 10-bit data “a” first and proceeds to “j”. This allows data to be read and matched to the form shown in Appendix B, “8B/10B Valid Characters.”

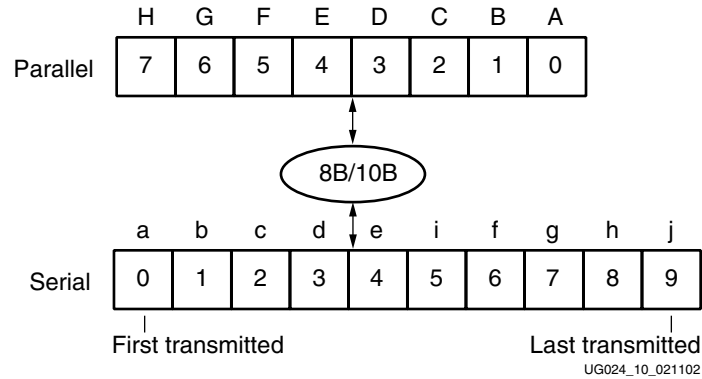

Figure 2-15: 8B/10B Parallel to Serial Conversion

The serial data bit sequence is dependent on the width of the parallel data. The most significant byte is always sent first, regardless of the whether 1-byte, 2-byte, or 4-byte paths are used. The least significant byte is always last. Figure 2-16 shows a case when the serial data corresponds to each byte of the parallel data. TXDATA [31:24] is serialized and sent out first, followed by TXDATA [23:16], TXDATA [15:8], and finally TXDATA [7:0]. The 2-byte path transmits TXDATA [15:8] and then TXDATA [7:0].

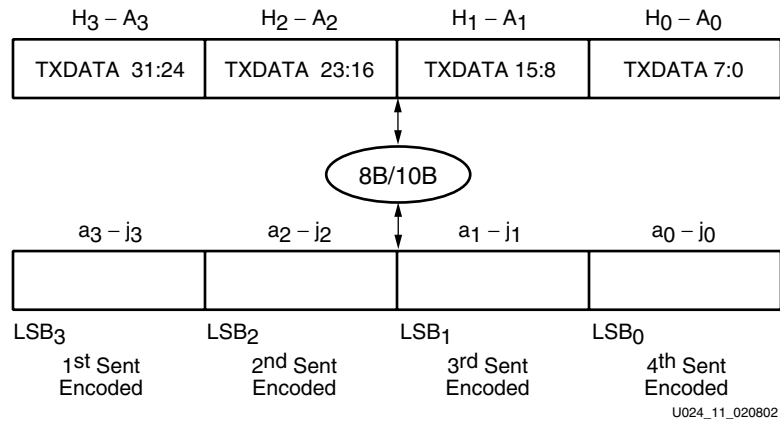

Figure 2-16: 4-Byte Serial Structure

HDL Code Examples: Transceiver Bypassing of 8B/10B Encoding

8B/10B encoding can be bypassed by the transceiver. The TXBYPASS8B10B is set to 1111; the RXDECODE attribute is set to FALSE to create the extra two bits needed for a 10-bit data bus; and TXCHARDISPMODE, TXCHARDISPVAL, RXCHARISK, and RXRUNDISP are added to the 8-bit data bus.

Please use the Architecture Wizard to create instantiation templates. This wizard creates code and instantiation templates that define the attributes for a specific application.

SERDES Alignment

Overview

Serializer

The multi-gigabit transceiver multiplies the reference frequency provided on the reference clock input (REFCLK) by 20, or by 10 if half-rate operation is selected. Data is converted from parallel to serial format and transmitted on the TXP and TXN differential outputs.

The electrical polarity of TXP and TXN can be interchanged through the TXPOLARITY port. This option can either be programmed or controlled by an input at the FPGA core TX interface. This facilitates recovery from situations where printed circuit board traces have been reversed.

Deserializer

The RocketIO transceiver core accepts serial differential data on its RXP and RXN inputs. The clock/data recovery circuit extracts clock phase and frequency from the incoming data stream and re-times incoming data to this clock. The recovered clock is presented on output RXRECCLK at 1/20 of the received serial data rate.

The receiver is capable of handling either transition-rich 8B/10B streams or scrambled streams, and can withstand a string of up to 75 non-transitioning bits without an error.

Word alignment is dependent on the state of comma detect bits. If comma detect is enabled, the transceiver recognizes up to two 10-bit preprogrammed characters. Upon detection of the character or characters, RXCOMMADET is driven High and the data is synchronously aligned. If a comma is detected and the data is aligned, no further alignment alteration takes place. If a comma is received and realignment is necessary, the data is realigned and RXREALIGN is asserted. The realignment indicator is a distinct output. The transceiver continuously monitors the data for the presence of the 10-bit character(s). Upon each occurrence of the 10-bit character, the data is checked for word alignment. If comma detect is disabled, the data is not aligned to any particular pattern. The programmable option allows a user to align data on plus-comma, minus-comma, both, or a unique user-defined and programmed sequence.

The electrical polarity of RXP and RXN can be interchanged through the RXPOLARITY port. This can be useful in the event that printed circuit board traces have been reversed.

Ports and Attributes

Comma definition can be accomplished using the attributes discussed below. This method of definition makes the MGT extremely flexible in implementing different protocols.

ALIGN_COMMA_MSB

This attribute determines where the commas will reside in the parallel received data. The comma indicates to the deserializer how to parallelize the data. However, with the multiple data path widths available, the PCS portion must determine where to place the comma in the parallel data bytes.

When ALIGN_COMMA_MSB is FALSE, the PCS may place the comma in any of the RXDATA bytes. In the 1-byte mode, of course, there is only one location in which the comma can be placed. In the 2-byte and 4-byte paths, some uncertainty exists as to which byte will contain the comma, as shown in [Table 2-12](#).

When ALIGN_COMMA_MSB is TRUE, the PCS places the comma into the most significant byte (MSB) of RXDATA in the 2-byte mode. Because the PCS is optimized for the 2-byte mode, some uncertainty exists in the 4-byte mode as to which byte will contain the comma, as shown in Table 2-12. See “Receive Data Path 32-bit Alignment” for more details on this case.

Table 2-12: Possible Locations of Comma Character

ALIGN_COMMA_MSB:	Data Path Width:						
	1 byte	2 bytes		4 bytes			
	[7:0]	[15:8]	[7:0]	[31:24]	[23:16]	[15:8]	[7:0]
TRUE	√	√		√		√	
FALSE	√	√	√	√	√	√	√

ENPCOMMAALIGN, ENMCOMMAALIGN

These two alignment ports control how the PMA aligns incoming serial data. It can align on a minus-comma (negative disparity), a plus-comma (positive disparity), both, or neither if comma alignment is not desired. These signals are latched inside the transceiver with RXRECCLK.

Care must be taken not to de-assert these signals at the improper time. Comma detection may be vulnerable to spurious realignment if RXRECCLK occurs at the wrong time. To avoid this problem, ENPCOMMAALIGN and ENMCOMMAALIGN should be passed through a flip-flop that is clocked with RXRECCLK. These flip-flops should be located near the MGT, and RXRECCLK should use local interconnect (not global clock resources) to reduce skew. For both top and bottom edges, the best slices to use are in the CLB immediately to the left of the transceiver, next to the bottom of the transceiver. For the top side of the chip, this is the fourth CLB row; for the bottom side, the bottom CLB row. For example, for the XC2VP7, here are the best slices to use for two of the transceivers:

- For GT_X0Y1 (top edge), the best slices are SLICE_X15Y72 and SLICE_X15Y73.
- For GT_X0Y0 (bottom edge), the best slices are SLICE_X14Y0 and SLICE_X14Y1.

This must be done for each MGT. Figure 2-17 shows this recommendation.

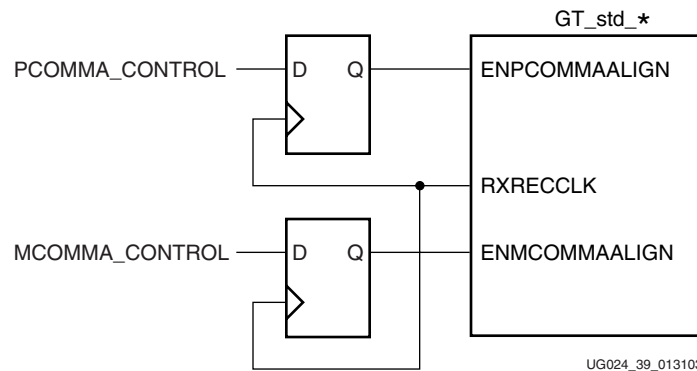
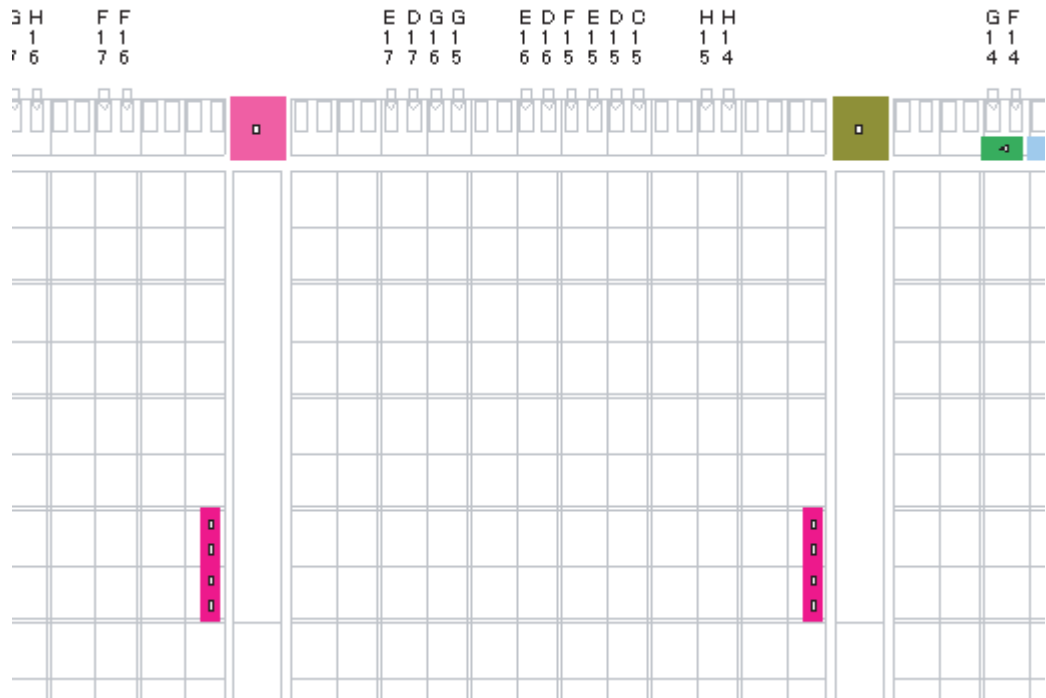

Figure 2-17: Synchronizing Comma Align Signals to RXRECCLK

Product Not Recommended for New Designs

Figure 2-18 and Figure 2-19 show floorplanner layouts for the two examples given above.



ug024_43_031303

Figure 2-18: Top MGT Comma Control Flip-Flop Ideal Locations

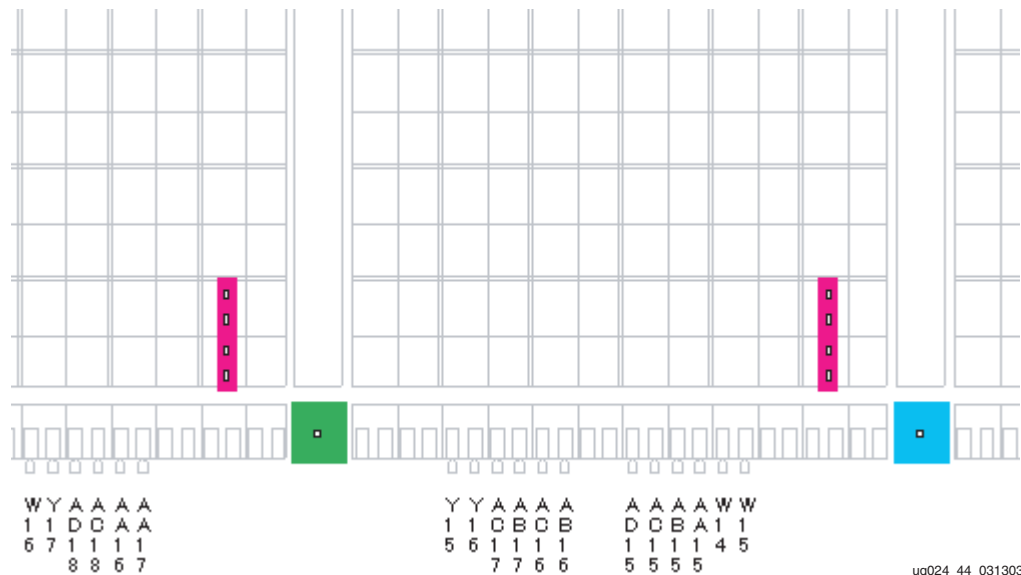

ug024_44_031303

Figure 2-19: Bottom MGT Comma Control Flip-Flop Ideal Locations

PCOMMA_DETECT, MCOMMA_DETECT

These two control attributes define when RXCOMMADET signals that a comma has been received. When only PCOMMA_DETECT is TRUE, RXCOMMADET signals when a plus-comma is received, but not a minus-comma. When only MCOMMA_DET is TRUE, RXCOMMADET signals when a minus-comma is received, but not a plus-comma. If both attributes are TRUE, RXCOMMADET will signal when either comma character is received.

COMMA_10B_MASK, PCOMMA_10B_VALUE, MCOMMA_10B_VALUE

The RocketIO transceiver allows the user to define a comma character using these three attributes. The COMMA_10B_MASK bits are used in conjunction with PCOMMA_10B_VALUE (to define a plus-comma) or MCOMMA_10B_VALUE (to define a minus-comma) to define some number of recognized comma characters. High bits in the mask condition the corresponding bits in PCOMMA_10B_VALUE or MCOMMA_10B_VALUE to matter, while Low bits in the mask function as a “don’t care” conditioner.

For example, with COMMA_10B_MASK set to 1111111000 (meaning the three least significant bits don’t matter) and PCOMMA_10B_VALUE is 0011111000, the comma detection unit will recognize the following characters as plus-commas:

```
0011111000 (K28.7)
0011111001 (K28.1)
0011111010 (K28.5)
0011111011 through 0011111111 (not valid comma characters)
```

Using the same value in PCOMMA_10B_VALUE but setting COMMA_10B_MASK to 1111111111 (meaning *all* the bits in PCOMMA_10B_VALUE matter), the comma detection unit will recognize only the 0011111000 (K28.7) sequence, which matches the value of PCOMMA_10B_VALUE exactly.

DEC_PCOMMA_DETECT, DEC_MCOMMA_DETECT, DEC_VALID_COMMA_ONLY

These signals only pertain to the 8B/10B decoder, not the comma alignment circuitry. The DEC_PCOMMA_DETECT and DEC_MCOMMA_DETECT control the 8B/10B decoder to signal the RXCHARISCOMMA port if a plus-comma or minus-comma is received. This is described in the table below.

DEC_VALID_COMMA_ONLY, for most applications, should be set to TRUE. If valid data is being transmitted and hence received, then an invalid comma would arise only in the case of a bit error, in which case RXCHARISCOMMA would not be asserted in the presence of bit errors. If set to FALSE, then RXCHARISCOMMA will be asserted for invalid K-characters.

RXREALIGN

This status signal indicates whenever, the serial data is realigned from a comma character in the data stream. This signal will not necessarily go High after the transceiver is reset. If

ENPCOMMAALIGN and ENMCOMMAALIGN are both set to zero then this signal should not go High. See [Table 2-13](#).

RXCHARISCOMMA

This signal is similar to RXCHARISK, except that it signals that a specific byte of RXDATA is a comma character. However, this definition only holds true for when 8B/10B encoding/decoding is enabled. This port is controlled by the DEC_* attributes and is shown in [Table 2-13](#). If the 8B/10B decoder is bypassed, this port is undefined.

RXCOMMADET

This signal indicates if a comma character has been detected in the serial data. The definition of this port is defined by the PCOMMA_DETECT and MCOMMA_DETECT attributes. This signal is clocked off RXRECCLK, and to reliably have the signal pulse for all the data width configurations, this pulse may change with respect to the USRCLKs.

Table 2-13: Effects of Comma-Related Ports and Attributes

Port or Attribute	Affects RXCHARISCOMMA	Affects RXCOMMADET	Affects Character Alignment and RXREALIGN
DEC_VALID_COMMA_ONLY DEC_PCOMMA_DETECT DEC_MCOMMA_DETECT	√		
PCOMMA_10B_VALUE MCOMMA_10B_VALUE		√	√
PCOMMA_DETECT MCOMMA_DETECT		√	
ENPCOMMAALIGN ENMCOMMAALIGN			√

Clock Recovery

Overview

Clock Synthesizer

Synchronous serial data reception is facilitated by a clock/data recovery circuit. This circuit uses a fully monolithic Phase-Locked Loop (PLL), which does not require any external components. The clock/data recovery circuit extracts both phase and frequency from the incoming data stream. The recovered clock is presented on output RXRECCLK at 1/20 of the serial received data rate.

The gigabit transceiver multiplies the reference frequency provided on the reference clock input (REFCLK) by 20.

No fixed phase relationship is assumed between REFCLK, RXRECCLK, and/or any other clock that is not tied to either of these clocks. When the 4-byte or 1-byte receiver data path is used, RXUSRCLK and RXUSRCLK2 have different frequencies (1:2), and each edge of the slower clock is aligned to a falling edge of the faster clock. The same relationships apply to TXUSRCLK and TXUSRCLK2. See [Table 2-5, page 43](#), for details.

Clock and Data Recovery

The clock/data recovery (CDR) circuits lock to the reference clock automatically if the data is not present. For proper operation, TXUSRCLK must have the exact same frequency as REFCLK. REFCLK, RXUSRCLK, and the incoming stream (RXRECCLK) must not exceed ± 100 ppm of frequency variation.

It is critical to keep power supply noise low in order to minimize common and differential noise modes into the clock/data recovery circuitry. See “PCB Design Requirements,” page 109, for more details.

Clock Correction

Clock RXRECCLK (the recovered clock) reflects the data rate of the incoming data. Clock RXUSRCLK defines the rate at which the FPGA core consumes the data. Ideally, these rates are identical. However, since the clocks typically have different sources, one of the clocks is faster than the other. The receiver buffer accommodates this difference between the clock rates. See Figure 2-20.

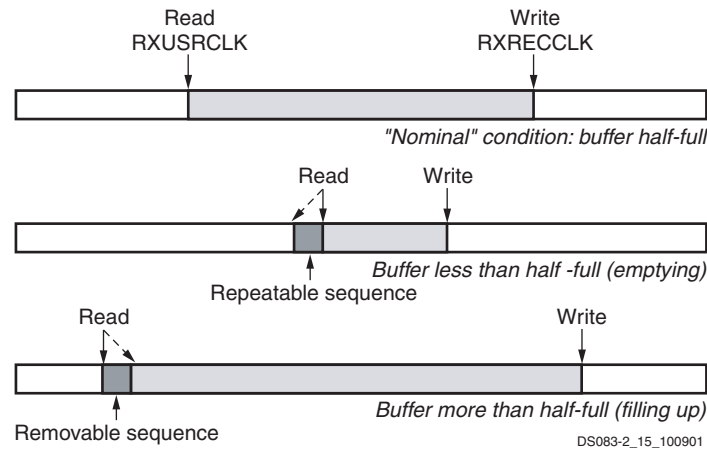

Figure 2-20: Clock Correction in Receiver

Nominally, the buffer is always half-full. This is shown in the top buffer, where the shaded area represents buffered data not yet read. Received data is inserted via the write pointer under control of RXRECCLK. The FPGA core reads data via the read pointer under control of RXUSRCLK. The half-full/half-empty condition of the buffer gives a cushion for the differing clock rates. This operation continues indefinitely, regardless of whether or not “meaningful” data is being received. When there is no meaningful data to be received, the incoming data consists of IDLE characters or other padding.

If RXUSRCLK is faster than RXRECCLK, the buffer becomes more empty over time. The clock correction logic corrects for this by decrementing the read pointer to reread a repeatable byte sequence. This is shown in the middle buffer, Figure 2-20, where the solid read pointer decrements to the value represented by the dashed pointer. By decrementing the read pointer instead of incrementing it in the usual fashion, the buffer is partially refilled. The transceiver inserts a single repeatable byte sequence when necessary to refill a buffer. If the byte sequence length is greater than one, and if attribute CLK_COR_REPEAT_WAIT is 0, then the transceiver can repeat the same sequence multiple times until the buffer is refilled to the half-full condition.

Similarly, if RXUSRCLK is slower than RXRECCLK, the buffer fills up over time. The clock correction logic corrects for this by incrementing the read pointer to skip over a removable byte sequence that need not appear in the final FPGA core byte stream. This is shown in the bottom buffer, [Figure 2-20](#), where the solid read pointer increments to the value represented by the dashed pointer. This accelerates the emptying of the buffer, preventing its overflow. The transceiver design skips a single byte sequence, when necessary, to partially empty a buffer. If attribute CLK_COR_REPEAT_WAIT is 0, the transceiver can also skip four consecutive removable byte sequences in one step, to further empty the buffer when necessary.

These operations require the clock correction logic to recognize a byte sequence that can be freely repeated or omitted in the incoming data stream. This sequence is generally an IDLE sequence, or other sequence comprised of special values that occur in the gaps separating packets of meaningful data. These gaps are required to occur sufficiently often to facilitate the timely execution of clock correction.

The clock correction logic has the ability to remove up to four IDLE sequences during a clock correction. How many IDLEs are removed depends on several factors, including how many IDLEs are received and whether CLK_COR_KEEP_IDLE is TRUE or FALSE. For example, if three IDLEs are received and CLK_COR_KEEP_IDLE is set to TRUE, at least one IDLE sequence must remain after clock correction has been completed. This limits the clock correction logic to remove only two of the three IDLE sequences. If CLK_COR_KEEP_IDLE is FALSE, then all three IDLEs can be removed.

[Table 2-14](#) illustrates the relationship between the number of IDLE sequences removed, the inherent stability of REFCLK, and the number of bytes allowed between clock correction sequences.

Table 2-14: Data Bytes Allowed Between Clock Corrections as a Function of REFCLK Stability and IDLE Sequences Removed

REFCLK Stability	Bytes Allowed Between Clock Correction Sequences ⁽¹⁾			
	Remove 1 IDLE ⁽²⁾ Sequence:	Remove 2 IDLE Sequences:	Remove 3 IDLE Sequences:	Remove 4 IDLE Sequences:
100 ppm	5,000	10,000	15,000	20,000
50 ppm	10,000	20,000	30,000	40,000
20 ppm	25,000	50,000	75,000	100,000

Notes:

1. All numbers are approximate.
2. IDLE = the defined clock correction sequence.

Ports and Attributes

CLK_CORRECT_USE

This attribute controls whether the PCS will repeat/skip the clock correction sequences (CCS) from the elastic buffer to compensate for differences between the clock recovered from serial data and the reference clocks. When this attribute is set to TRUE, the clock correction is enabled. If set to FALSE, clock correction is disabled. When clock correction is disabled, RXRECCLK must drive the receive logic in the fabric. Otherwise, the elastic buffer may over/underflow.

Clock correction may be used with other encoding protocols, but they must have a 10-bit alignment scheme. This is required so the comma detection logic can properly align the data in the elastic buffer, allowing the clock correction logic to properly read out data to the FPGA fabric.

RX_BUFFER_USE

The RX_BUFFER_USE attribute controls if the elastic buffer is bypassed or not. Most applications use this buffer for clock correction and channel bonding. (See [“Channel Bonding \(Channel Alignment\),”](#) page 79.) It is recommended that this attribute always be set to TRUE, since this buffer allows a way to cross the clock domains of RXRECCLK and the fabric RXUSRCLK/RXUSRCLK2.

CLK_COR_SEQ_*_*

To accommodate many different protocols, the MGT features programmability that allows it to detect a 1-, 2-, or 4-byte clock correction sequence (CCS), such as may be used in Gigabit Ethernet (2-byte) or Fibre Channel (4-byte). The attributes CLK_COR_SEQ_*_* and CLK_COR_SEQ_LEN (below) define the CCS that the PCS recognizes. Both SEQ_1 and SEQ_2 can be used at the same time if multiple CCSs are required. As shown in [Table 2-15](#), the example CCS has two possible modes, one for when 8B/10B encoding is used, the other for when 8B/10B encoding is bypassed. The most significant bit of the CCS determines whether it is applicable to an 8-bit (encoded) or a 10-bit (unencoded) sequence.

These sequences require that the encoding scheme allows the comma detection and alignment circuitry to properly align data in the elastic buffer. (See [“CLK_CORRECT_USE”](#), above). The bit definitions are the same as shown earlier in the Vitesse channel-bonding example. (See [“Receiving Vitesse Channel Bonding Sequence.”](#))

Table 2-15: Clock Correction Sequence / Data Correlation for 16-Bit Data Port

Attribute Settings			Character	CHARISK	TXDATA (hex)
CLK_COR_SEQ	8-Bit Data Mode	10-Bit Data Mode (8B/10B Bypass)			
CLK_COR_SEQ_1_1	00110111100	10011111010	K28.5	1	BC
CLK_COR_SEQ_1_2	00010010101	11010100010	D21.4	0	95
CLK_COR_SEQ_1_3	00010110101	11010101010	D21.5	0	B5
CLK_COR_SEQ_1_4	00010110101	11010101010	D21.5	0	B5

CLK_COR_SEQ_LEN

To define the CCS length, this attribute takes the integer value 1, 2, 3, or 4. Table 2-16 shows which sequences are used for the four possible settings of CLK_COR_SEQ_LEN.

Table 2-16: Applicable Clock Correction Sequences

CLK_COR_SEQ_LEN	CLK_COR_SEQ_1 That Are Applicable	CLK_COR_SEQ_2 That Are Applicable ⁽¹⁾
1	1_1	2_1
2	1_1, 1_2	2_1, 2_2
3	1_1, 1_2, 1_3	2_1, 2_2, 2_3
4	1_1, 1_2, 1_3, 1_4	2_1, 2_2, 2_3, 2_4

Notes:

1. Applicable only if CLK_COR_SEQ_2_USE is set to TRUE.

CLK_COR_INSERT_IDLE_FLAG, CLK_COR_KEEP_IDLE, CLK_COR_REPEAT_WAIT

These attributes help control how clock correction is implemented.

CLK_COR_INSERT_IDLE_FLAG is a TRUE/FALSE attribute that defines the output of the RXRUNDISP port. When set to TRUE, RXRUNDISP is raised for the first byte of each inserted (repeated) clock correction sequence (8B/10B decoding enabled). When set to FALSE (default), RXRUNDISP denotes the running disparity of RXDATA (8B/10B decoding enabled).

CLK_COR_KEEP_IDLE is a TRUE/FALSE attribute that controls whether or not the final byte stream must retain at least one clock correction sequence. When set to FALSE (default), the clock correction logic is allowed to remove all clock correction sequences if needed to recenter the elastic buffer. When set to TRUE, it forces the clock correction logic to retain at least one clock correction sequence per continuous stream of clock correction sequences.

Example: Elastic buffer is 75% full and clock correction is needed. (IDLE is the defined clock correction sequence.)

Data stream written into elastic buffer:



Data stream read out of elastic buffer (CLK_COR_KEEP_IDLE = FALSE)

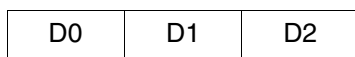

Data stream read out of elastic buffer (CLK_COR_KEEP_IDLE = TRUE)



CLK_COR_REPEAT_WAIT is an integer attribute (0-31) that controls frequency of repetition of clock correction operations. This attribute specifies the minimum number of RXUSRCLK cycles *without* clock correction that must occur between successive clock corrections. For example, if this attribute is 3, then at least three RXUSRCLK cycles without

clock correction must occur before another clock correction sequence can occur. If this attribute is 0, no limit is placed on how frequently clock correction can occur.

Example: Elastic buffer is 25% full, clock correction is needed, and one sequence is repeated per clock correction. (IDLE is the defined clock correction sequence.)

Data stream written into elastic buffer:

D0	IDLE	IDLE	IDLE	D1	D2
----	------	------	------	----	----

Data stream read out of elastic buffer (CLK_COR_REPEAT_WAIT = 0):

D0	IDLE	IDLE	IDLE	IDLE	IDLE	IDLE	D1	D2
----	------	------	------	------	------	------	----	----

Data stream read out of elastic buffer (CLK_COR_REPEAT_WAIT = 1):

D0	IDLE	IDLE	IDLE	IDLE	IDLE	D1	D2
----	------	------	------	------	------	----	----

The percent that the buffer is full, together with the value of CLK_COR_REPEAT_WAIT, determines how many times the clock correction sequence is repeated during each clock correction.

Synchronization Logic

Overview

For some applications, it is beneficial to know if incoming data is valid or not, and if the MGT is synchronized on the data. For applications using the 8B/10B encoding scheme, the RX_LOSS_OF_SYNC FSM does this. It can be programmed to lose sync after a specified number of invalid data characters are received.

Ports and Attributes

RXCLKCORCNT

Clock correction count (RXCLKCORCNT) is a three-bit signal. It signals if clock correction has occurred, and whether the elastic buffer realigned the data by skipping or repeating data in the buffer. It also signals if channel bonding has occurred. [Table 2-17](#) defines the eight binary states of RXCLKCORCNT.

Table 2-17: RXCLKCORCNT Definition

RXCLKCORCNT[2:0]	Significance
000	No channel bonding or clock correction occurred for current RXDATA
001	Elastic buffer skipped one clock correction sequence for current RXDATA
010	Elastic buffer skipped two clock correction sequence for current RXDATA
011	Elastic buffer skipped three clock correction sequence for current RXDATA

Table 2-17: RXCLKCORCNT Definition (Continued)

RXCLKCORCNT[2:0]	Significance
100	Elastic buffer skipped four clock correction sequence for current RXDATA
101	Elastic buffer executed channel bonding for current RXDATA
110	Elastic buffer repeated two clock correction sequences for current RXDATA
111	Elastic buffer repeated one clock correction sequences for current RXDATA

RX_LOS_INVALID_INCR, RX_LOS_THRESHOLD

These two signals determine how fast an invalid character advances the RXLOSSOF SYNC FSM counter before loss of sync is considered to have occurred. RX_LOS_INVALID_INCR determines how quickly the occurrence of invalid characters is “forgotten” in the presence of subsequent valid characters. For example, RX_LOS_INVALID_INCR = 4 means that four consecutive valid characters after an invalid character will reset the counter.

RX_LOS_THRESHOLD determines when the counter has reached the point where the link is considered to be “out of sync.”

RX_LOSS_OF_SYNC_FSM

The transceiver’s FSM is driven by RXRECCLK and uses status from the data stream prior to the elastic buffer. This is intended to give early warning of possible problems well before corrupt data appears on RXDATA. RX_LOSS_OF_SYNC_FSM, a TRUE/FALSE attribute, indicates what the output of the RXLOSSOF SYNC port (see below) means.

Note: RX_LOSS_OF_SYNC_FSM only indicates valid data. It is assumed that the PLL is locked. The values are undefined if the PLL is not locked.

RXLOSSOF SYNC

If RX_LOSS_OF_SYNC_FSM = FALSE, then RXLOSSOF SYNC[1] High indicates that the transceiver has received an invalid character, and RXLOSSOF SYNC[0] High indicates that a channel-bonding sequence has been recognized.

If RX_LOSS_OF_SYNC_FSM = TRUE, then the two bits of RXLOSSOF SYNC reflect the state of the RXLOSSOF SYNC FSM. The state machine diagram in Figure 2-21 and the three subsections following describe the three states of the RXLOSSOF SYNC FSM

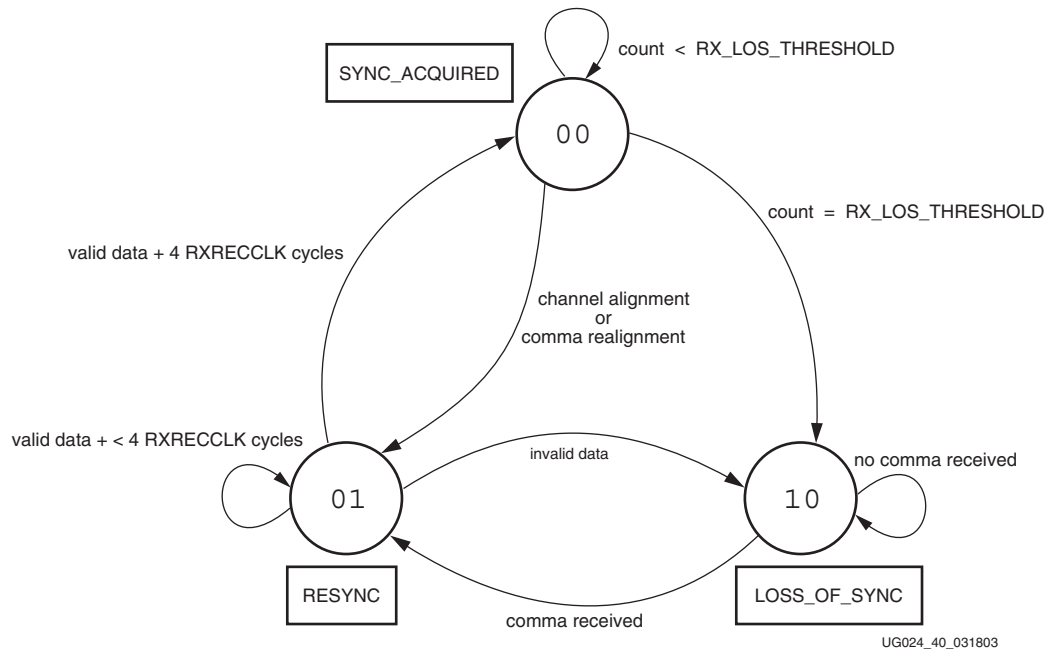

Figure 2-21: RXLOSSOFSYNC FSM States

SYNC_ACQUIRED (RXLOSSOFSYNC = 00)

In this state, a counter is decremented by 1 (but not past 0) for a valid received symbol and incremented by RX_LOS_INVALID_INCR for an invalid symbol. If the count reaches or exceeds RX_LOS_THRESHOLD, the FSM moves to state LOSS_OF_SYNC. Otherwise, if a channel bonding (alignment) sequence has just been written into the elastic buffer, or if a comma realignment has just occurred, the FSM moves to state RESYNC. Otherwise, the FSM remains in state SYNC_ACQUIRED.

RESYNC (RXLOSSOFSYNC = 01)

The FSM waits in this state for four RXRECCLK cycles and then goes to state SYNC_ACQUIRED, unless an invalid symbol is received, in which case the FSM goes to state LOSS_OF_SYNC.

LOSS_OF_SYNC (RXLOSSOFSYNC = 10)

The FSM remains in this state until a comma is received, at which time it goes to state RESYNC.

Channel Bonding (Channel Alignment)

Overview

Some gigabit I/O standards such as XAUI specify the use of multiple transceivers in parallel for even higher data rates. Words of data are split into bytes, with each byte sent over a separate channel (transceiver). See [Figure 2-22](#).

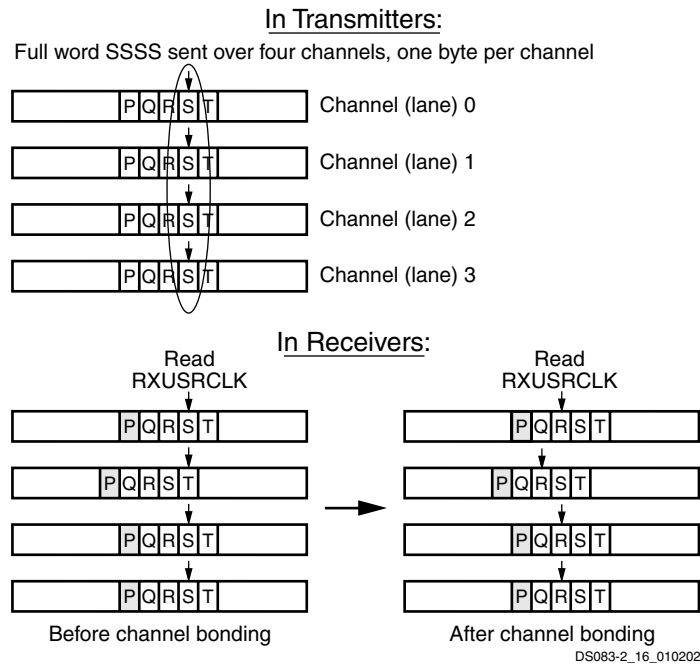

Figure 2-22: Channel Bonding (Alignment)

The top half of the figure shows the transmission of words split across four transceivers (channels or lanes). PPPP, QQQQ, RRRR, SSSS, and TTTT represent words sent over the four channels.

The bottom-left portion of the figure shows the initial situation in the FPGA's receivers at the other end of the four channels. Due to variations in transmission delay—especially if the channels are routed through repeaters—the FPGA core might not correctly assemble the bytes into complete words. The bottom-left illustration shows the incorrect assembly of data words PQPP, QRQQ, RSRR, etc.

To support correction of this misalignment, the data stream includes special byte sequences that define corresponding points in the several channels. In the bottom half of [Figure 2-22](#), the shaded "P" bytes represent these special characters. Each receiver recognizes the "P" channel bonding character, and remembers its location in the buffer. At some point, one transceiver designated as the Master instructs all the transceivers to align to the channel bonding character "P" (or to some location relative to the channel bonding character). After this operation, the words transmitted to the FPGA core are properly aligned: RRRR, SSSS, TTTT, etc., as shown in the bottom-right portion of [Figure 2-22](#). To ensure that the channels remain properly aligned following the channel bonding operation, the Master transceiver must also control the clock correction operations described in the previous section for all channel-bonded transceivers.

Channel Bonding (Alignment) Operation

Channel bonding is the technique of tying several serial channels together to create one aggregate channel. Several channels are fed on the transmit side by one parallel bus and reproduced on the receive side as the identical parallel bus. The maximum number of serial differential pairs that can be bonded is 24. For implementation guidelines, see “Implementation Tools,” page 121.

Channel bonding allows those primitives that support it to send data over multiple “channels.” Among these primitives are GT_CUSTOM, GT_INFINIBAND, GT_XAUI, and GT_AURORA. To “bond” channels together, there is always one “Master.” The other channels can either be a SLAVE_1_HOP or SLAVE_2_HOPS. SLAVE_1_HOP is a Slave to a Master that can also be daisy chained to a SLAVE_2_HOPS. A SLAVE_2_HOPS can only be a Slave to a SLAVE_1_HOP and its CHBONDO does not connect to another transceiver. To designate a transceiver as a Master or a Slave, the attribute CHAN_BOND_MODE must be set to one of three designations: Master, SLAVE_1_HOP, or SLAVE_2_HOPS. To shut off channel bonding, set the transceiver attribute to “off.” The possible values that can be used are shown in Table 2-18.

Table 2-18: Bonded Channel Connections

Mode	CHBONDI	CHBONDO
OFF	NA	NA
MASTER	NA	Slave 1 CHBONDI
SLAVE_1_HOP	Master CHBONDO	Slave 2 CHBONDI
SLAVE_2_HOPS	Slave 1 CHBONDO	NA

Note: All standards that use both clock correction and channel bonding require a gap greater than or equal to 4 bytes between clock correction and channel bonding sequences. If a user creates his/her own protocol that uses clock correction and channel bonding, the user must ensure that there is at least a 4 byte gap between the sequences.

The channel bonding sequence is similar in format to the clock correction sequence. This sequence is set to the appropriate sequence for the primitives supporting channel bonding. The GT_CUSTOM is the only primitive allowing modification to the sequence. These sequences are comprised of one or two sequences of length up to 4 bytes each, as set by CHAN_BOND_SEQ_LEN and CHAN_BOND_SEQ_2_USE. Other control signals include the attributes:

- CHAN_BOND_WAIT
- CHAN_BOND_OFFSET
- CHAN_BOND_LIMIT
- CHAN_BOND_ONE_SHOT

Typical values for these attributes are:

CHAN_BOND_WAIT = 8

CHAN_BOND_OFFSET = CHAN_BOND_WAIT

CHAN_BOND_LIMIT = 2 × CHAN_BOND_WAIT

Lower values are not recommended. Use higher values only if channel bonding sequences are farther apart than 17 bytes.

Table 2-19 shows different settings for CHAN_BOND_ONE_SHOT and ENCHANSYNC in Master and Slave applications.

Table 2-19: Master/Slave Channel Bonding Attribute Settings

	Master	Slave
CHAN_BOND_ONE_SHOT	TRUE or FALSE as desired	FALSE
ENCHANSYNC	Dynamic control as desired	Tie High

Ports and Attributes

CHAN_BOND_MODE

An MGT can be designated as one of three types when used in a channel-bonding scheme. The type is designated by CHAN_BOND_MODE, the three values of which are MASTER, SLAVE_1_HOP, and SLAVE_2_HOPS. (A fourth mode, OFF, is used when channel bonding is not being performed.) The Master always controls, for itself and for Slaves of either type, when channel bonding and clock correction will occur.

Masters are always connected directly to a SLAVE_1_HOP, and indirectly to a SLAVE_2_HOPS via daisy-chain through a SLAVE_1_HOP. This topology improves the timing characteristics of the CHBONDO and CHBONDI buses.

ENCHANSYNC

ENCHANSYNC controls when channel bonding is enabled. Table 2-19 shows the recommended settings for Master and Slaves. To counter the possibility of a bit error causing a false channel bonding sequence to occur, this port is usually de-asserted once a group of channels have been successfully aligned.

CHAN_BOND_ONE_SHOT

As with ENCHANSYNC, many applications will require that the channels be aligned only once. CHAN_BOND_ONE_SHOT = TRUE allows the Master to initiate a channel bonding only once. This remains true even if more channel bonding sequences are received. (The channels may be aligned again if RXRESET is asserted and then deasserted, and ENCHANSYNC is deasserted and then reasserted.)

CHAN_BOND_ONE_SHOT may be set to FALSE when very few channel bonding sequences appear in the data stream. (For Slave instantiations, this attribute should *always* be set to FALSE. See Table 2-19.) When the channel bonding sequence appears frequently in the data stream, however, it is recommended that this attribute be set to TRUE in order to prevent the RX buffer from over- or underflowing.

CHAN_BOND_SEQ_*_*, CHAN_BOND__SEQ_LEN, CHAN_BOND_SEQ_2_USE

The *channel bonding sequence* (CBS) is similar in format to the clock correction sequence. The CBS is set to the appropriate sequence for the primitives supporting channel bonding. GT_CUSTOM is the only primitive allowing modification to the sequence. These sequences are comprised of one or two sequences of length up to 4 bytes each, as set by CHAN_BOND_SEQ_LEN and CHAN_BOND_SEQ_2_USE.

These CBSs should be unique from other delimiters in the data stream, including Clock Correction Sequence, IDLE, Start of Frame, and End of Frame. As with clock correction, there are multiple sequences that can be defined (GT_CUSTOM only). The primary CBS is defined by `CHAN_BOND_SEQ_1_*`, where `*` = a number from 1 to 4.

If a second CBS is required, `CHAN_BOND_SEQ_2_USE` must be set to `TRUE`, and `CHAN_BOND_SEQ_2_*` used to define the second CBS; otherwise, `CHAN_BOND_SEQ_2_USE` should be left at its default value, `FALSE`. See [“Receiving Vitesse Channel Bonding Sequence,” page 65](#), for the bit breakdown of the sequence definition.

Finally, `CHAN_BOND_SEQ_LEN` defines the CBS length as 1 to 4 bytes. When set to anything other than 4, only those sequences are defined. For example, if `CHAN_BOND_SEQ_LEN` is set to 2, only `CHAN_BOND_SEQ_1_1` and `CHAN_BOND_SEQ_1_2` need to be defined.

CHAN_BOND_WAIT, CHAN_BOND_OFFSET, CHAN_BOND_LIMIT

These three attributes define how the Master performs channel alignment of the RX buffer. The typical values of these attributes are:

`CHAN_BOND_WAIT = 8`

`CHAN_BOND_WAIT` roughly defines the maximum number of bytes by which the Slave can lag the Master. Due to internal pipelining, the equation should be $(\text{CHAN_BOND_WAIT} - 3.5) \text{ bytes} = \# \text{ of bytes Slave may lag Master}$. For example, if `CHAN_BOND_WAIT = 8`, the Slave may lag the Master by 4.5 bytes. While this type of lag is equivalent to approximately 14 ns at 3.125 Gb/s, it is recommended that channel links be matched as closely as possible.

The equation that produces this maximum lag time result is

$\text{lag time [ns]} = (1 / \text{serial speed [Gb/s]}) \cdot \text{number of lag bytes} \cdot 10 \text{ bits/byte}$
or, for schemes that do not use 8B/10B encoding,

$(1 / \text{serial speed [Gb/s]}) \cdot \text{number of 10-bit lag characters} \cdot 10 \text{ bits/character}$

In the example above, $1/3.125 \text{ Gb/s} \cdot 4.5 \text{ bytes} \cdot 10 \text{ bits/byte} = 14.4 \text{ ns}$.

The recommended setting of 8 is set for protocols such as Infiniband and XAUI, which can repeat the CBS every 16 and 17 bytes respectively. However, `CHAN_BOND_WAIT` can grow accordingly if CBSs are spaced farther apart.

`CHAN_BOND_OFFSET = CHAN_BOND_WAIT`

`CHAN_BOND_OFFSET` measures the number of bytes past the beginning of the channel bonding sequence. However, this value must always equal `CHAN_BOND_WAIT`.

`CHAN_BOND_LIMIT = 2X CHAN_BOND_WAIT`

`CHAN_BOND_LIMIT` defines the expiration time after which the Slave will invalidate the most recently seen CBS location in the RX buffer. For proper alignment, this value must always be set to two times `CHAN_BOND_WAIT`.

CHBONDDONE

This port indicates when a channel alignment has occurred in the MGT. When it is asserted, RXDATA is valid after RXCLKCORCNT goes to a 101.

Note: The Slave's RXCLKCORCNT will go to 101 regardless of whether the channel bonding was successful or not. To determine if channel bonding was successful, check both this signal and RXCLKCORCNT.

CHBONDI, CHBONDO

These two 4-bit ports are used by the Master MGT to control its clock correction and channel bonding, as well as those of any Slaves bonded to it. CHBONDO of the Master is connected to CHBONDI of a SLAVE_1_HOP. The signal is then daisy-chained from SLAVE_1_HOP CHBONDO to a SLAVE_2_HOPS CHBONDI. See [Figure 4-1](#) and [Figure 4-2, page 122](#), and [Table 2-18, page 80](#), for examples. The three least significant bits correlate to the value of the RXCLKCORCNT port. These four bits allow the Master to control when the Slaves perform clock correction. This keeps channels from going out of sync if, for instance, one Slave repeated a CCS while another skipped.

RXCLKCORCNT, RXLOSSOFSYNC

These signals are mainly used for clock correction. However, they can convey some information relevant to channel bonding as well. Refer to ["RXCLKCORCNT"](#) and ["RXLOSSOFSYNC," page 77](#).

Troubleshooting

Factors that influence channel bonding include:

- *Skew between Master and Slave CBS arrival time*, both Master-lags-Slave and Slave-lags-Master cases. The larger the separation, the larger CHAN_BOND_WAIT needs to be.
- *Arrival time between consecutive CBSs*. The smaller the separation is between consecutive CBSs, the smaller CHAN_BOND_WAIT needs to be set to ensure that the Master aligns to the intended sequence instead of the one after or the one before.

There are several possibilities that could cause unsuccessful channel bonding:

- *Slave's CBS lagging the master by too much*. Essentially, the Slave does not see a CBS when CHBONDO is asserted.
- *Master CBS lags the slave by too much*. In this case, the slave's CBS sequence has exceeded CHAN_BOND_LIMIT and has expired.
- *CBS sequences appear more frequently than CHAN_BOND_LIMIT allows*, causing the Slave to align to a CBS before or after the expected one.

CRC (Cyclic Redundancy Check)

Overview

Cyclic Redundancy Check (CRC) is a procedure to detect errors in the received data. The RocketIO transceiver CRC logic supports the 32-bit invariant CRC calculation used by Infiniband, Fibre Channel, and Gigabit Ethernet.

CRC Operation

On the transmitter side, the CRC logic recognizes where the CRC bytes should be inserted and replaces four placeholder bytes at the tail of a data packet with the computed CRC. For Gigabit Ethernet and Fibre Channel, transmitter CRC can adjust certain trailing bytes to generate the required running disparity at the end of the packet. This is discussed further in the “FIBRE_CHAN” and “ETHERNET” sections under “CRC_FORMAT,” page 85.

On the receiver side, the CRC logic verifies the received CRC value, supporting the same standards as above.

Upon reset, the CRC logic starts with an initial value of all 1s.

CRC Generation

RocketIO transceivers support a 32-bit invariant CRC (fixed 32-bit polynomial shown below) for Gigabit Ethernet, Fibre Channel, Infiniband, and user-defined modes.

$$x^{32} + x^{26} + x^{23} + x^{22} + x^{16} + x^{12} + x^{11} + x^{10} + x^8 + x^7 + x^5 + x^4 + x^2 + x^1 + 1$$

The CRC recognizes the SOP (Start of Packet), EOP (End of Packet), and other packet features to identify the beginning and end of data. These SOP and EOP are defined by CRC_FORMAT for ETHERNET, INFINIBAND, and FIBRE_CHAN, and in these cases the user does not need to set CRC_START_OF_PKT and CRC_END_OF_PKT. Where CRC_FORMAT is USER_MODE (user-defined), CRC_START_OF_PKT and CRC_END_OF_PKT are used to define SOP and EOP.



Figure 2-23: CRC Packet Format

The transmitter computes 4-byte CRC on the packet data between the SOP and EOP (excluding the CRC placeholder bytes). The transmitter inserts the computed CRC just before the EOP. The transmitter modifies trailing Idles or EOP if necessary to generate correct running disparity for Gigabit Ethernet and Fibre Channel. The receiver recomputes CRC and verifies it against the inserted CRC. Figure 2-23 shows the packet format for CRC generation. The empty boxes are only used in certain protocols (Ethernet). The user logic must create a four-byte placeholder for the CRC by placing it in TXDATA. Otherwise, data is overwritten.

CRC Latency

Enabling CRC increases the transmission latency from TXDATA to TXP and TXN. The enabling of CRC does not affect the latency from RXP and RXN to RXDATA. The typical and maximum latencies, expressed in TXUSRCLK/RXUSRCLK cycles, are shown in [Table 2-20](#). For timing diagrams expressing these relationships, please see Module 3 of the [Virtex-II Pro Data Sheet](#).

Table 2-20: Effects of CRC on Transceiver Latency⁽¹⁾

	TXDATA to TXP and TXN in TXUSRCLK Cycles		RXP and RXN to RXDATA in RXUSRCLK Cycles ⁽³⁾	
	Typical	Maximum	Typical	Maximum
CRC Disabled	8	11	25	42 ⁽²⁾
CRC Enabled	14	17	25	42 ⁽²⁾

Notes:

1. See [Table 2-6](#) and [Table 2-7](#) for all MGT block latency parameters.
2. This maximum may occur when certain conditions are present, and clock correction and channel bonding are enabled. If these functions are both disabled, the maximum will be near the typical values.
3. To further reduce receive-side latency, refer to [Appendix C, "Related Online Documents."](#)

Ports and Attributes

TX_CRC_USE,
RX_CRC_USE

These two attributes control whether the MGT CRC circuitry is enabled or bypassed. When set to TRUE, CRC is enabled. When set to FALSE, CRC is bypassed and must be implemented in the FPGA fabric.

CRC_FORMAT

There are four possible CRC modes: USER_MODE, FIBRE_CHAN, ETHERNET, and INFINIBAND. This attribute is modifiable only for the GT_XAUI and GT_CUSTOM primitives. Each mode has a Start of Packet (SOP) and End of Packet (EOP) setting to determine where to start and end the CRC monitoring. USER_MODE allows the user to define the SOP and EOP by setting the CRC_START_OF_PKT and CRC_END_OF_PKT to one of the valid K-characters ([Table B-2, page 143](#)). The CRC is controlled by RX_CRC_USE and TX_CRC_USE. Whenever these attributes are set to TRUE, CRC is used.

The four modes are defined in the subsections following.

USER_MODE

USER_MODE is the simplest CRC methodology. The CRC checks for the SOP and EOP, calculates CRC on the data, and leaves the four remainders directly before the EOP. The CRC form for the user-defined mode is shown in [Figure 2-24](#), along with the timing for when RXCHECKINGCRC and RXCRCERR are asserted High with respect to the incoming data.

To check the CRC error detection logic in a testing mode such as serial loopback, a CRC error can be forced by setting TXFORCECERCERR to High, which incorporates an error into the transmitted data. When that data is received, it appears "corrupted," and the receiver

signals an error by asserting RXCRCERR High at the same time RXCHECKINGCRC goes High. User logic determines the procedure that is invoked when a CRC error occurs.

Note: Data length must be greater than 20 bytes for USER_MODE CRC generation. For CRC to operate correctly, at least four gap bytes are required between EOP of one packet and SOP of the next packet. The gap may contain clock correction sequences, provided that at least 4 bytes of gap remain after all clock corrections.

FIBRE_CHAN

The FIBRE_CHAN CRC is similar to USER_MODE CRC (Figure 2-24), with one exception: In FIBRE_CHAN, SOP and EOP are predefined protocol delimiters. Unlike USER_MODE, FIBRE_CHAN does not need to define the attributes CRC_START_OF_PKT and CRC_END_OF_PKT. Both USER_MODE and FIBRE_CHAN, however, disregard SOP and EOP in CRC computation.

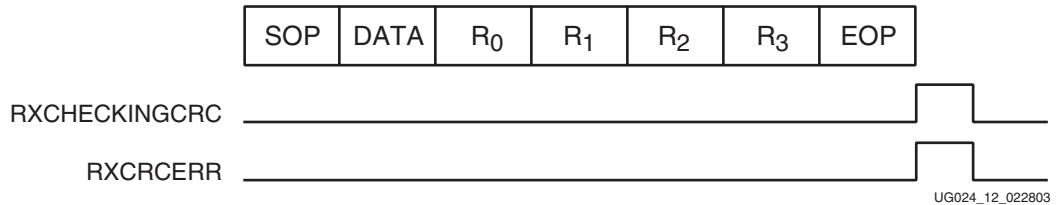

Figure 2-24: USER_MODE / FIBRE_CHAN Mode

Designs should generate only the EOP frame delimiter for a beginning running disparity (RD) that is negative. (These are the frame delimiters that begin with /K28.5/D21.4/ or /K28.5/D10.4/.) Never generate the EOP frame delimiter for a beginning RD that is positive. (These are the frame delimiters that begin with /K28.5/D21.5/ or /K28.5/D10.5/.) When the RocketIO CRC determines that the running disparity must be inverted to satisfy Fibre Channel requirements, it will convert the second byte of the EOP frame delimiter (D21.4 or D10.4) to the value required to invert the running disparity (D21.5 or D10.5).

Note that CRC generation for EOP requires that the transmitted K28.5 be left-justified in the MGT's internal two-byte data path. Observing the following restrictions assures correct alignment of the packet delimiters:

- 4-byte data path: K28.5 must appear in TXDATA[31:24] or TXDATA[15:8].
- 2-byte data path: K28.5 must appear in TXDATA[15:8].
- 1-byte data path: K28.5 must be strobed into the MGT on rising TXUSRCLK2 only when TXUSRCLK is High.

Note: Minimum data length for this mode is 24 bytes, not including the CRC placeholder.

Note: When CRC_FORMAT=FIBRE_CHAN, TX_CRC_USE must be set to TRUE. Otherwise, occasional errors will occur in the transmitted data stream. RX_CRC_USE can be either TRUE or FALSE in this usage.

ETHERNET

The Ethernet CRC is more complex (Figure 2-25). The SOP, EOP, and Preamble are neglected by the CRC. The extension bytes are special "K" characters in special cases. The extension bytes are untouched by the CRC as are the Trail bits, which are added to maintain packet length.

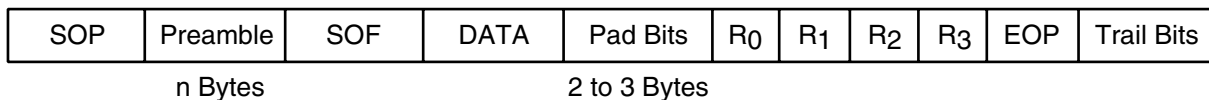

UG024_13_101602

Figure 2-25: Ethernet Mode

Designs should generate only the /K28.5/D16.2/ IDLE sequence for transmission, never /K28.5/D5.6/. When the RocketIO CRC determines that the running disparity must be inverted to satisfy Gigabit Ethernet requirements, it will convert the first /K28.5/D16.2/ IDLE following a packet to /K28.5/D5.6/, performing the necessary conversion.

Note: As noted in Figure 2-25, pad bits are used to assure that the header, data, and CRC total to the 64-byte minimum packet length. For packets that are already 64 bytes or longer, pad bits are not used.

Note that CRC generation for IDLE requires that the transmitted K28.5 be left-justified in the MGT's internal two-byte data path. Observing the following restrictions assures correct alignment of the packet delimiters:

- 4-byte data path: K28.5 must appear in TXDATA[31:24] or TXDATA[15:8].
- 2-byte data path: K28.5 must appear in TXDATA[15:8].
- 1-byte data path: K28.5 must be strobed into the MGT on rising TXUSRCLK2 only when TXUSRCLK is High.

Note: Minimum data length for this mode is defined by the protocol requirements.

Note: For correct operation of the Gigabit Ethernet CRC function, transmitted and received frames must comply with the 802.3 specification regarding Gigabit Ethernet. This includes the preamble maximum length.

INFINIBAND

The Infiniband CRC is the most complex mode, and is not supported in the CRC generator. Infiniband CRC contains two computation types: an invariant 32-bit CRC, the same as in Ethernet protocol; and a variant 16-bit CRC, which is not supported in the hard core. Infiniband CRC must be implemented entirely in the FPGA fabric.

There are also two Infiniband Architecture (IBA) packets, a local and a global. Both of these IBA packets are shown in Figure 2-26.

Local IBA

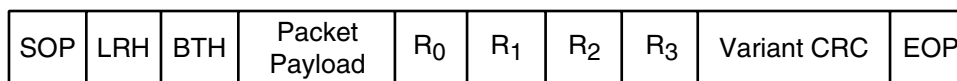

Global IBA

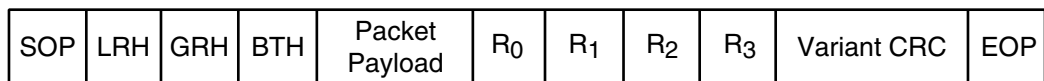

UG024_14_020802

Figure 2-26: Infiniband Mode

The CRC is calculated with certain bits masked in LRH and GRH, depending on whether the packet is local or global. The size of these headers is shown in [Table 2-21](#).

Table 2-21: Global and Local Headers

Packet	Description	Size
LRH	Local Routing Header	8 Bytes
GRH	Global Routing Header	40 Bytes
BTH	IBA Transport Header	12 Bytes

The CRC checks the LNH (Link Next Header) of the LRH. LRH is shown in [Figure 2-27](#), along with the bits the CRC uses to evaluate the next packet.

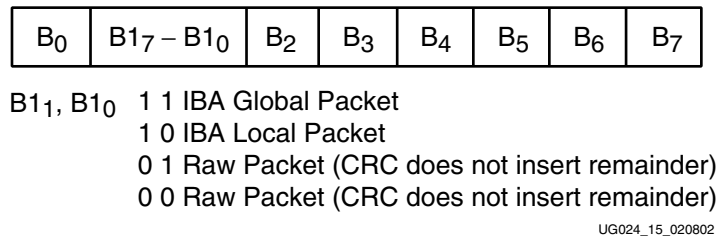

Figure 2-27: Local Route Header

Note: Minimum data length for this mode is defined by the protocol requirements.

Because of the complexity of the CRC algorithms and implementations, especially with Infiniband, a more in-depth discussion is beyond the scope of this manual.

CRC_START_OF_PACKET, CRC_END_OF_PACKET

When implementing USER_MODE CRC, Start of Packet (SOP) and End of Packet (EOP) must be defined for the CRC logic. These delimiters must be one of the defined K-characters (see [Table B-2, page 143](#)). These must be different than a clock correction sequence (CCS) or IDLE sequence; otherwise, the CRC will mistake the CCS or IDLE for SOP/EOP.

Note: These attribute are not applicable to the other CRC formats.

RXCHECKINGCRC, RXCRCERR

These two signals are status ports for the CRC circuitry.

RXCHECKINGCRC is asserted within several USRCLKs of the EOF being received from RXDATA. This signals that the CRC circuitry has identified the SOF and the EOF.

If a CRC error occurred, RXCRCERR will be asserted at the same time that RXCHECKINGCRC goes High.

TXFORCECRCERR, TX_CRC_FORCE_VALUE

To test the CRC logic in either the MGT or the FPGA fabric, TXFORCECRCERR and TX_CRC_FORCE_VALUE may be used to invoke a CRC error. When TXFORCECRCERR is asserted High for at least one USRCLK2 cycle during data transmission (between SOP and EOP), the CRC circuitry is forced to XOR TXDATA with TX_CRC_FORCE_VALUE, creating a bit error. This should cause the receiver to register that a CRC error has occurred.

RocketIO CRC Support Limitations

There are limitations to the CRC support provided by the RocketIO transceiver core:

- RocketIO CRC support is implementable for single-channel use only. Computation and byte-striping of CRC across multiple bonded channels is not supported. For that usage, the CRC logic can be implemented in the FPGA fabric.
- The RocketIO transceiver does not compute the 16-bit variant CRC used for Infiniband, and thus does not fulfill the Infiniband CRC requirement. Infiniband CRC can be computed in the FPGA fabric.
- All CRC formats have minimum allowable packet sizes. These limits are larger than those set by the user mode, and are defined by the specific protocol.

Fabric Interface (Buffers)

Overview: Transmitter and Elastic (Receiver) Buffers

Both the transmitter and the receiver include buffers (FIFOs) in the data path. This section gives the reasons for including the buffers and outlines their operation.

Transmitter Buffer (FIFO)

The transmitter buffer's write pointer (TXUSRCLK) is frequency-locked to its read pointer (REFCLK). Therefore, clock correction and channel bonding are not required. The purpose of the transmitter's buffer is to accommodate a phase difference between TXUSRCLK and REFCLK. Proper operation of the circuit is only possible if the FPGA clock (TXUSRCLK) is frequency-locked to the reference clock (REFCLK). Phase variations of up to one clock cycle are allowable. A simple FIFO suffices for this purpose. A FIFO depth of four permits reliable operation with simple detection of overflow or underflow, which might occur if the clocks are not frequency-locked. Overflow or underflow conditions are detected and signaled at the interface.

Receiver Buffer

The receiver buffer is required for two reasons:

- To accommodate the slight difference in frequency between the recovered clock RXRECCLK and the internal FPGA core clock RXUSRCLK (clock correction)
- To allow realignment of the input stream to ensure proper alignment of data being read through multiple transceivers (channel bonding)

The receiver uses an *elastic buffer*, where "elastic" refers to the ability to modify the read pointer for clock correction and channel bonding.

Ports and Attributes

TXBUFERR

When High, this port indicates that a transmit buffer underflow or overflow has occurred. Once set High, TXRESET must be asserted to clear this bit.

TX_BUFFER_USE

This attribute allows the user to bypass the transmit buffer. A value of FALSE bypasses the buffer, while a TRUE keeps the buffer in the data path. This attribute should always be set to TRUE.

RXBUFSTATUS

This 2-bit port indicates the status of the receiver elastic buffer. RXBUFSTATUS[1] High indicates if an overflow/underflow error has occurred. (Once set High, the assertion of RXRESET or RXREALIGN clears this bit.) RXBUFSTATUS[0] High indicates that the elastic buffer is at least half-full.

RX_BUFFER_USE

When set to FALSE, this attribute causes the receive buffer to be bypassed. It should normally be set to TRUE, since channel bonding and clock correction use the receive buffer for realignment. When the buffer is bypassed, the user logic must be clocked with RXRECCLK.

Miscellaneous Signals

Ports and Attributes

Several ports and attributes of the MGT have very unique functionality. The following do not have large roles in the other functionality discussed so far:

RX_DATA_WIDTH, TX_DATA_WIDTH

These two attributes define the data width in bytes of RXDATA and TXDATA respectively. The possible values of each attribute are 1, 2, and 4, which correspond to 8-, 16-, and 32-bit data buses when 8B/10B encoding/decoding is used. (See [“8B/10B Encoding/Decoding,”](#) page 60.) The bus widths are 10, 20, and 40 bits when 8B/10B encoding/decoding is bypassed.

SERDES_10B

This attribute allows the MGT to expand its serial speed range. The normal operational speed range of 1.0 Gb/s to 3.125 Gb/s (20 times the reference clock rate) is obtained when this attribute is set to FALSE. When set to TRUE, the MGT serial data will run at 10 times the reference clock rate, producing a speed range of 600 Mb/s to 1 Gb/s.

Table 2-22: Serial Speed Ranges as a Function of SERDES_10B

SERDES_10B	Reference Clock Range	Serial Speed Range
TRUE	60 – 100 MHz	600 Mb/s – 1.0 Gb/s
FALSE	50 – 156.25 MHz	1.0 Gb/s – 3.125 Gb/s

TERMINATION_IMP

Receive Termination

On-chip termination is provided at the receiver, eliminating the need for external termination. The receiver includes programmable on-chip termination circuitry for 50Ω (default) or 75Ω impedance.

Transmit Termination

On-chip termination is provided at the transmitter, eliminating the need for external termination. Programmable options exist for 50Ω (default) and 75Ω termination.

TXPOLARITY, RXPOLARITY, TXINHIBIT

A differential pair has a positive-designated and a negative-designated component. If for some reason the polarity of these components is switched between two transceivers, the data will not be passed properly. If this occurs, TXPOLARITY will invert the definition of the TXN and TXP pins. On the receiver side of the MGT, the RXPOLARITY port can invert the definition of RXN and RXP.

For some protocols, the MGT must turn off the TXN/TXP pins. The TXINHIBIT port shuts off the transmit pins and forces them to a constant value (TXN = 0, TXP = 1). Asserting TXINHIBIT also disables internal serial loopback.

TX_DIFF_CTRL, PRE_EMPHASIS

These two attributes control analog functionality of the MGT.

The TX_DIFF_CTRL attribute is used to compensate for signal attenuation in the link between transceivers. It has five possible values of 400, 500, 600, 700, and 800 mV. These values represent the peak-to-peak amplitude of *one* component of the differential pair; the full differential peak-to-peak amplitude is two times these values.

The PRE_EMPHASIS attribute has four values—10%, 20%, 25%, and 33%—which are designated by 0, 1, 2, and 3 respectively. Pre-emphasis is discussed in greater detail in [Chapter 3, “Analog Design Considerations.”](#)

LOOPBACK

To facilitate testing without the requirement to apply patterns or measure data at gigahertz rates, two programmable loopback features are available.

One option, *serial* loopback, places the gigabit transceiver into a state where transmit data is directly fed back to the receiver. An important point to note is that the feedback path is at the output pads of the transmitter. This tests the entirety of the transmitter and receiver.

The second loopback path is a *parallel* path that checks only the digital circuitry. When the parallel option is enabled, the serial loopback path is disabled. However, the transmitter outputs remain active and data is transmitted over the serial link. If TXINHIBIT is asserted, TXN is forced High and TXP is forced Low until TXINHIBIT is de-asserted.

LOOPBACK allows the user to send the data that is being transmitted directly to the receiver of the transceiver. [Table 2-23](#) shows the three loopback modes.

Table 2-23: LOOPBACK Modes

Input Value	Mode	Description
00	Normal Mode	Normal Mode is selected during normal operation. The transmitted data is sent out the differential transmit ports (TXN, TXP) and are sent to another transceiver without being sent to its own receiver logic. During normal operation, LOOPBACK should be set to 00.
01	Internal Parallel Mode	Internal Parallel Mode allows testing the transmit and receive interface logic PCS without having to go into the PMA section of the transceiver, or to another transceiver. See Figure 2-28 .
10	Internal Serial Mode	<p>Internal Serial Mode is used to check that the entire transceiver is working properly, including testing of 8B/10B encoding/decoding. This emulates what another transceiver would receive as data from this specific transceiver design.</p> <p>Since the TXP/TXN pins are still being driven during this loopback mode, PCB traces on these pins should be terminated to remove reflections; otherwise, loopback bit errors could result. Termination can be accomplished by any of a variety of methods. Two examples:</p> <ul style="list-style-type: none"> • Connect SMA terminators on the TXP/TXN SMA connectors (if applicable), or simply use 50Ω resistors on the transmitter backplane pins. • Connect the unterminated TXP/TXN to the RXP/RXN of another instantiated transceiver, allowing its receiver inputs to terminate the transmitter outputs.

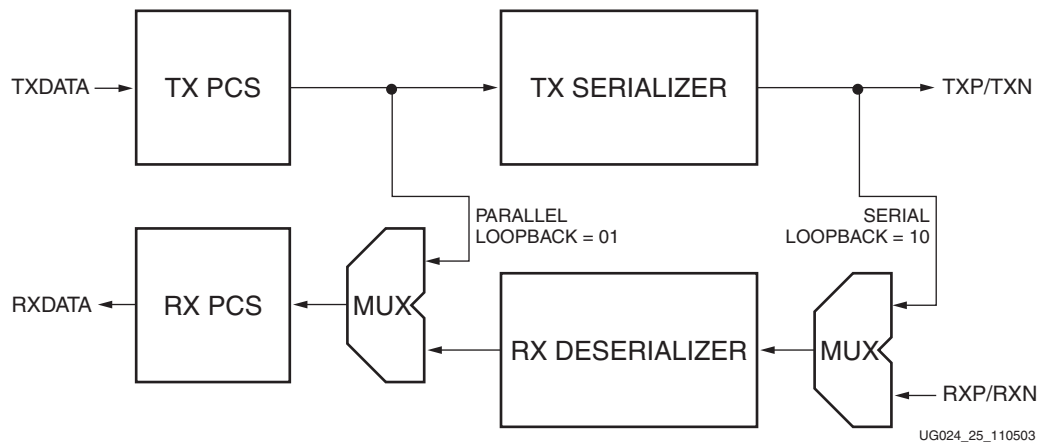

Figure 2-28: Serial and Parallel Loopback Logic

Other Important Design Notes

Receive Data Path 32-bit Alignment

The RocketIO transceiver uses the attribute `ALIGN_COMMA_MSB` to align protocol delimiters with the use of comma characters (special K-characters K28.5, K28.1, and K28.7 for most protocols). Setting `ALIGN_COMMA_MSB` to `TRUE/FALSE` determines where the comma characters appear on the `RXDATA` bus. When `ALIGN_COMMA_MSB` is set to `FALSE`, the comma can appear in any byte lane of `RXDATA` in the 2- and 4-byte primitives. When `ALIGN_COMMA_MSB` is set to `TRUE`, the comma appears in `RXDATA[15:8]` for the 2-byte primitives, and in either `RXDATA[15:8]` or `RXDATA[31:24]` for the 4-byte primitives. (See “[ALIGN_COMMA_MSB](#),” page 67.)

In the case of a 4-byte primitive, the transceiver sets comma alignment with respect to its 2-byte internal data path, but it does not constrain the comma to appear only in `RXDATA[31:24]`. Logic must be designed in the FPGA fabric to handle comma alignment for the 32-bit primitives when implementing certain protocols. (Note that FPGA logic is *not* required for 1-byte and 2-byte configurations.)

One such protocol is Fibre Channel. Delimiters such as `IDLES`, `SOF`, and `EOF` are four bytes long, and are assumed by the protocol logic to be aligned on a 32-bit boundary. The Fibre Channel `IDLE` delimiter is four bytes long and is composed of characters K28.5, D21.4, D21.5, and D21.5. The comma, K28.5, is transmitted in `TXDATA[31:24]`, which the protocol logic expects to be received in `RXDATA[31:24]`.

Using [Table B-1, page 135](#), and [Table B-2, page 143](#), the `IDLE` delimiter can be translated into a hexadecimal value `0xBC95B5B5` that represents the 32-bit `RXDATA` word. On the 32-bit `RXDATA` interface, the received word is either 32-bit aligned or misaligned, as shown in [Table 2-24](#). In the table, “*pp*” indicates a byte from a previous word of data.

Table 2-24: 32-bit RXDATA, Aligned versus Misaligned

	RXDATA [31:24]	RXDATA [23:16]	RXDATA [15:8]	RXDATA [7:0]
32-bit aligned	BC	95	B5	B5
CHARISCOMMA	1	0	0	0
32-bit misaligned	<i>pp</i>	<i>pp</i>	BC	95
CHARISCOMMA	0	0	1	0

When RXDATA is 32-bit aligned, the logic should pass RXDATA through to the protocol logic without modification. A properly aligned data flow is shown in Figure 2-29.

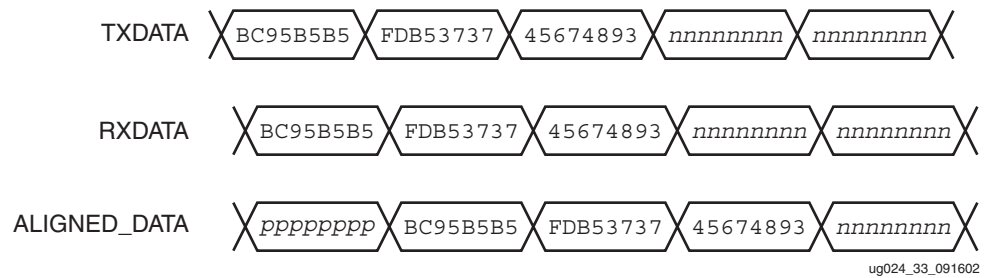

Figure 2-29: RXDATA Aligned Correctly

When RXDATA is 32-bit misaligned, the word requiring alignment is split between consecutive RXDATA words in the data stream, as shown in Figure 2-30. (RXDATA_REG in the figure refers to the design example code in “32-bit Alignment Design,” page 95.)



Figure 2-30: Realignment of RXDATA

This conditional shift/delay operation on RXDATA also must be performed on the status outputs RXNOTINTABLE, RXDISPERR, RXCHARISK, RXCHARISCOMMA, and RXRUNDISP in order to keep them properly synchronized with RXDATA.

It is not possible to adjust RXCLKCORCNT appropriately for shifted/delayed RXDATA, because RXCLKCORCNT is summary data, and the summary for the shifted case cannot be recalculated.

32-bit Alignment Design

The following example code illustrates one way to create the logic to properly align 32-bit wide data with a comma in bits [31:24]. For brevity, most status bits are not included in this example design; however, these should be shifted in the same manner as RXDATA and RXCHARISK.

Note that when using a 40-bit data path (8B/10B bypassed), a similar realignment scheme may be used, but it cannot rely on RXCHARISCOMMA for comma detection.

Verilog

```

/*****
 *
 *   XILINX IS PROVIDING THIS DESIGN, CODE, OR INFORMATION "AS IS"
 *   AS A COURTESY TO YOU, SOLELY FOR USE IN DEVELOPING PROGRAMS AND
 *   SOLUTIONS FOR XILINX DEVICES. BY PROVIDING THIS DESIGN, CODE,
 *   OR INFORMATION AS ONE POSSIBLE IMPLEMENTATION OF THIS FEATURE,
 *   APPLICATION OR STANDARD, XILINX IS MAKING NO REPRESENTATION
 *   THAT THIS IMPLEMENTATION IS FREE FROM ANY CLAIMS OF INFRINGEMENT,
 *   AND YOU ARE RESPONSIBLE FOR OBTAINING ANY RIGHTS YOU MAY REQUIRE
 *   FOR YOUR IMPLEMENTATION. XILINX EXPRESSLY DISCLAIMS ANY
 *   WARRANTY WHATSOEVER WITH RESPECT TO THE ADEQUACY OF THE
 *   IMPLEMENTATION, INCLUDING BUT NOT LIMITED TO ANY WARRANTIES OR
 *   REPRESENTATIONS THAT THIS IMPLEMENTATION IS FREE FROM CLAIMS OF
 *   INFRINGEMENT, IMPLIED WARRANTIES OF MERCHANTABILITY AND FITNESS
 *   FOR A PARTICULAR PURPOSE.
 *
 *   (c) Copyright 2002 Xilinx Inc.
 *   All rights reserved.
 *****/

// Virtex-II Pro RocketIO comma alignment module
//
// This module reads RXDATA[31:0] from a RocketIO transceiver
// and copies it to
// its output, realigning it if necessary so that commas
// are aligned to the MSB position
// [31:24]. The module assumes ALIGN_COMMA_MSB is TRUE,
// so that the comma
// is already aligned to [31:24] or [15:8].
//
//   Outputs
//
// aligned_data[31:0] -- Properly aligned 32-bit ALIGNED_DATA
// sync -- Indicator that aligned_data is properly aligned
// aligned_rxisk[3:0] - properly aligned 4 bit RXCHARISK
// Inputs - These are all RocketIO inputs or outputs
// as indicated:
//
// usrclk2 -- RXUSRCLK2
// rxreset -- RXRESET
// rxisk[3:0] RXCHARISK[3:0]
// rxdata[31:0] RXDATA[31:0] -- (commas aligned to
//                                     [31:24] or [15:8])
// rxrealign -- RXREALIGN
// rxcommadet -- RXCOMMADET

```

```

// rxchariscomma3 -- RXCHARISCOMMA[3]
// rxchariscomma1 -- RXCHARISCOMMA[1]
//

module align_comma_32 ( aligned_data, aligned_rxisk, sync,
                      usrclk2, rxreset,
                      rxdata, rxisk,
                      rxrealign, rxcommadet,
                      rxchariscomma3, rxchariscomma1 );

    output [31:0] aligned_data;
    output [3:0]  aligned_rxisk;
    output                sync;

    reg [31:0] aligned_data;
    reg                sync;

    input                usrclk2;
    input                rxreset;
    input [31:0] rxdata;
    input [3:0]  rxisk;
    input                rxrealign;
    input                rxcommadet;
    input                rxchariscomma3;
    input                rxchariscomma1;

    reg [15:0] rxdata_reg;
    reg [1:0]  rxisk_reg;
    reg [3:0]  aligned_rxisk;
    reg                byte_sync;

    reg [3:0]  wait_to_sync;
    reg                count;

    // This process maintains wait_to_sync and count,
    // which are used only to
    // maintain output sync; this provides some idea
    // of when the output is properly
    // aligned, with the comma in aligned_data[31:24]. The
    // counter is set to a high value
    // whenever the elastic buffer is reinitialized;
    // that is, upon asserted RXRESET or
    // RXREALIGN. Count-down is enabled whenever a
    // comma is known to have
    // come through the comma detection circuit,
    // that is, upon an asserted RXREALIGN
    // or RXCOMMADET.

    always @ ( posedge usrclk2 )
    begin
        if ( rxreset )
        begin
            wait_to_sync <= 4'b1111;
            count        <= 1'b0;
        end
        else if ( rxrealign )
        begin
            wait_to_sync <= 4'b1111;
            count        <= 1'b1;
        end
    end

```



```
        end
        else
        begin
            if ( count && ( wait_to_sync != 4'b0000 ) )
                wait_to_sync <= wait_to_sync - 4'b0001;
            if ( rxcommadet )
                count <= 1'b1;
            end
        end
    end

    // This process maintains output sync, which indicates
    // when outgoing aligned_data
    // should be properly aligned, with the comma in aligned_data[31:24].
    // Output aligned_data is
    // considered to be in sync when a comma is seen on
    // rxdata (as indicated
    // by rxchariscomma3 or 1) after the counter wait_to_sync
    // has reached 0, indicating
    // that commas seen by the comma detection circuit
    // have had time to propagate to
    // aligned_data after initialization of the elastic buffer.

    always @ ( posedge usrclk2 )
    begin
        if ( rxreset | rxrealign )
            sync <= 1'b0;
        else if ( ( wait_to_sync == 4'b0000 ) &
            ( rxchariscomma3 | rxchariscomma1 ) )
            sync <= 1'b1;
        end

    // This process generates aligned_data with commas aligned in [31:24],
    // assuming that incoming commas are aligned to [31:24] or [15:8].
    // Here, you could add code to use ENPCOMMAALIGN and
    // ENMCOMMAALIGN to enable a move back into the byte_sync=0 state.

    always @ ( posedge usrclk2 or posedge rxreset )
    begin
        if ( rxreset )
        begin
            rxdata_reg <= 16'h0000;
            aligned_data <= 32'h0000_0000;
            rxisk_reg <= 2'b00;
            aligned_rxisk <= 4'b0000;
            byte_sync <= 1'b0;
        end
        else
        begin
            rxdata_reg[15:0] <= rxdata[15:0];
            rxisk_reg[1:0] <= rxisk[1:0];
            if ( rxchariscomma3 )
            begin
                aligned_data[31:0] <= rxdata[31:0];
                aligned_rxisk[3:0] <= rxisk[3:0];
                byte_sync <= 1'b0;
            end
            else
            if ( rxchariscomma1 | byte_sync )
            begin
```

```

        aligned_data[31:0] <= { rxdata_reg[15:0], rxdata[31:16]
};
        aligned_rxisk[3:0]  <= { rxisk_reg[1:0], rxisk[3:2] };
        byte_sync    <= 1'b1;
        end
        else
        begin
            aligned_data[31:0] <= rxdata[31:0];
            aligned_rxisk <= rxisk;
        end
        end
    end
end

endmodule // align_comma_32

```

VHDL

```

-- *
-- *****
-- *****
-- *
-- * XILINX IS PROVIDING THIS DESIGN, CODE, OR INFORMATION "AS IS"
-- * AS A COURTESY TO YOU, SOLELY FOR USE IN DEVELOPING PROGRAMS AND
-- * SOLUTIONS FOR XILINX DEVICES.  BY PROVIDING THIS DESIGN, CODE,
-- * OR INFORMATION AS ONE POSSIBLE IMPLEMENTATION OF THIS FEATURE,
-- * APPLICATION OR STANDARD, XILINX IS MAKING NO REPRESENTATION
-- * THAT THIS IMPLEMENTATION IS FREE FROM ANY CLAIMS OF INFRINGEMENT,
-- * AND YOU ARE RESPONSIBLE FOR OBTAINING ANY RIGHTS YOU MAY REQUIRE
-- * FOR YOUR IMPLEMENTATION.  XILINX EXPRESSLY DISCLAIMS ANY
-- * WARRANTY WHATSOEVER WITH RESPECT TO THE ADEQUACY OF THE
-- * IMPLEMENTATION, INCLUDING BUT NOT LIMITED TO ANY WARRANTIES OR
-- * REPRESENTATIONS THAT THIS IMPLEMENTATION IS FREE FROM CLAIMS OF
-- * INFRINGEMENT, IMPLIED WARRANTIES OF MERCHANTABILITY AND FITNESS
-- * FOR A PARTICULAR PURPOSE.
-- *
-- * (c) Copyright 2002 Xilinx Inc.
-- * All rights reserved.
-- *
--*****

-- Virtex-II Pro RocketIO comma alignment module
--
-- This module reads RXDATA[31:0] from a RocketIO transceiver
-- and copies it to
-- its output, realigning it if necessary so that commas
-- are aligned to the MSB position
-- [31:24].  The module assumes ALIGN_COMMA_MSB is TRUE,
-- so that the comma
-- is already aligned to [31:24] or [15:8].
--
-- Outputs
--
-- aligned_data[31:0] -- Properly aligned 32-std_logic ALIGNED_DATA
-- sync -- Indicator that aligned_data is properly aligned
-- aligned_rxisk[3:0] --properly aligned 4-std_logic RXCHARISK
-- Inputs - These are all RocketIO inputs or outputs
-- as indicated:
--

```

Product Not Recommended for New Designs

```
-- usrclk2 -- RXUSRCLK2
-- rxreset -- RXRESET
-- rxdata[31:0] RXDATA[31:0] -- (commas aligned to
--                               [31:24] or [15:8])
-- rxisk[3:0] - RXCHARISK[3:0]
-- rxrealign -- RXREALIGN
-- rxcommadet -- RXCOMMADET
-- rxchariscomma3 -- RXCHARISCOMMA[3]
-- rxchariscomma1 -- RXCHARISCOMMA[1]
--
LIBRARY IEEE;
USE IEEE.std_logic_1164.all;
use IEEE.STD_LOGIC_ARITH.ALL;
use IEEE.Numeric_STD.all;
use IEEE.STD_LOGIC_UNSIGNED.ALL;

ENTITY align_comma_32 IS
  PORT (
    aligned_data      : OUT std_logic_vector(31 DOWNTO 0);
    aligned_rxisk     : OUT std_logic_vector(3 DOWNTO 0);
    sync              : OUT std_logic;
    usrclk2           : IN std_logic;
    rxreset           : IN std_logic;
    rxdata            : IN std_logic_vector(31 DOWNTO 0);
    rxisk             : IN std_logic_vector(3 DOWNTO 0);
    rxrealign        : IN std_logic;
    rxcommadet       : IN std_logic;
    rxchariscomma3   : IN std_logic;
    rxchariscomma1   : IN std_logic);
END ENTITY align_comma_32;

ARCHITECTURE translated OF align_comma_32 IS

  SIGNAL rxdata_reg      : std_logic_vector(15 DOWNTO 0);
  SIGNAL rxisk_reg       : std_logic_vector(1 DOWNTO 0);
  SIGNAL byte_sync       : std_logic;
  SIGNAL wait_to_sync    : std_logic_vector(3 DOWNTO 0);
  SIGNAL count           : std_logic;
  SIGNAL rxdata_hold     : std_logic_vector(31 DOWNTO 0);
  SIGNAL rxisk_hold     : std_logic_vector(3 DOWNTO 0);
  SIGNAL sync_hold      : std_logic;

BEGIN
  aligned_data <= rxdata_hold;
  aligned_rxisk <= rxisk_hold;
  sync <= sync_hold;

  -- This process maintains wait_to_sync and count,
  -- which are used only to
  -- maintain output sync; this provides some idea
  -- of when the output is properly
  -- aligned, with the comma in aligned_data[31:24].
  -- The counter is set to a high value
  -- whenever the elastic buffer is reinitialized;
  -- that is, upon asserted RXRESET or
  -- RXREALIGN. Count-down is enabled whenever a
  -- comma is known to have
  -- come through the comma detection circuit, that
```

```
-- is, upon an asserted RXREALIGN
-- or RXCOMMADET.

PROCESS (usrclk2)
BEGIN
  IF (usrclk2'EVENT AND usrclk2 = '1') THEN
    IF (rxreset = '1') THEN
      wait_to_sync <= "1111";
      count <= '0';
    ELSE
      IF (rxrealign = '1') THEN
        wait_to_sync <= "1111";
        count <= '1';
      ELSE
        IF (count = '1') THEN
          IF (wait_to_sync /= "0000") THEN
            wait_to_sync <= wait_to_sync - "0001";
          END IF;
        END IF;
        IF (rxcommadet = '1') THEN
          count <= '1';
        END IF;
      END IF;
    END IF;
  END IF;
END PROCESS;

-- This process maintains output sync, which
-- indicates when outgoing aligned_data
-- should be properly aligned, with the comma
-- in aligned_data[31:24]. Output aligned_data is
-- considered to be in sync when a comma is seen
-- on rxdata (as indicated
-- by rxchariscomma3 or 1) after the counter
-- wait_to_sync has reached 0, indicating
-- that commas seen by the comma detection circuit
-- have had time to propagate to
-- aligned_data after initialization of the elastic buffer.
```

```
PROCESS (usrclk2)
BEGIN
  IF (usrclk2'EVENT AND usrclk2 = '1') THEN
    IF ((rxreset OR rxrealign) = '1') THEN
      sync_hold <= '0';
    ELSE
      IF (wait_to_sync = "0000") THEN
        IF ((rxchariscomma3 OR rxchariscomma1) = '1') THEN
          sync_hold <= '1';
        END IF;
      END IF;
    END IF;
  END IF;
END PROCESS;
```

```
-- This process generates aligned_data with commas
-- aligned in [31:24],
-- assuming that incoming commas are aligned
-- to [31:24] or [15:8].
-- Here, you could add code to use ENPCOMMAALIGN and
-- ENMCOMMAALIGN to enable a move back into the
```

```
-- byte_sync=0 state.

PROCESS (usrclk2, rxreset)
BEGIN
  IF (rxreset = '1') THEN
    rxdata_reg <= "0000000000000000";
    rxdata_hold <= "00000000000000000000000000000000";
    rxisk_reg <= "00";
    rxisk_hold <= "0000";
    byte_sync <= '0';
  ELSIF (usrclk2'EVENT AND usrclk2 = '1') THEN
    rxdata_reg(15 DOWNT0 0) <= rxdata(15 DOWNT0 0);
    rxisk_reg(1 DOWNT0 0) <= rxisk(1 DOWNT0 0);

    IF (rxchariscomma3 = '1') THEN
      rxdata_hold(31 DOWNT0 0) <= rxdata(31 DOWNT0 0);
      rxisk_hold(3 DOWNT0 0) <= rxisk(3 DOWNT0 0);
      byte_sync <= '0';
    ELSE
      IF ((rxchariscomma1 OR byte_sync) = '1') THEN
        rxdata_hold(31 DOWNT0 0) <= rxdata_reg(15 DOWNT0 0) &
          rxdata(31 DOWNT0 16);
        rxisk_hold(3 DOWNT0 0) <= rxisk_reg(1 DOWNT0 0) &
          rxisk(3 DOWNT0 2);
        byte_sync <= '1';
      ELSE
        rxdata_hold(31 DOWNT0 0) <= rxdata(31 DOWNT0 0);
        rxisk_hold(3 DOWNT0 0) <= rxisk(3 DOWNT0 0);
      END IF;
    END IF;
  END IF;
END PROCESS;

END ARCHITECTURE translated;
```

Analog Design Considerations

Serial I/O Description

The RocketIO transceiver transmits and receives serial differential signals. This feature operates at a nominal supply voltage of 2.5 VDC. A serial differential pair consists of a true (V_P) and a complement (V_N) set of signals. The voltage difference represents the transferred data. Thus: $V_P - V_N = V_{DATA}$. Differential switching is performed at the crossing of the two complementary signals. Therefore, no separate reference level is needed. A graphical representation of this concept is shown in [Figure 3-1](#).

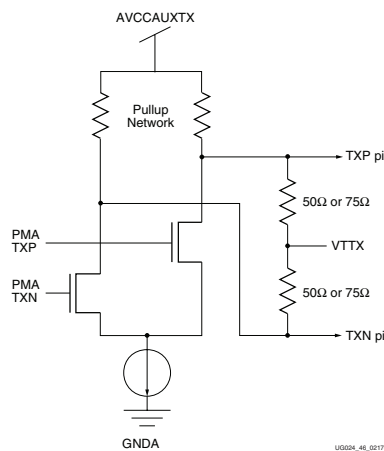

Figure 3-1: Differential Amplifier

The RocketIO transceiver is implemented in Current Mode Logic (CML). A CML output consists of transistors configured as shown in [Figure 3-1](#). CML uses a positive supply and offers easy interface requirements. In this configuration, both legs of the driver, V_P and V_N , sink current, with one leg always sinking more current than its complement. The CML output consists of a differential pair with 50Ω (or, optionally, 75Ω) source resistors. The signal swing is created by switching the current in a common-drain differential pair.

The differential transmitter specification is shown in [Table 3-1](#), [page 103](#).

Table 3-1: Differential Transmitter Parameters

Parameter		Min	Typ	Max	Units	Conditions
V_{OUT}	Serial output differential peak to peak (TXP/TXN)	800		1600	mV	Output differential voltage is programmable
V_{TTX}	Output termination voltage supply	1.8		2.625	V	

Table 3-1: Differential Transmitter Parameters (Continued)

Parameter		Min	Typ	Max	Units	Conditions
V_{TCM}	Common mode output voltage range (no transmission line connected)	1.1		1.5	V	
V_{TCM}	Common mode output voltage range (transmission line connected)	1.1		2.0	V	The common mode depends on coupling (DC or AC), VTTX, VTRX, and differential swing. Spice simulation gives the exact common mode voltage for any given system.
V_{ISKEW}	Differential output skew			15	ps	

Pre-emphasis Techniques

In pre-emphasis, the initial differential voltage swing is boosted to create a stronger rising or falling waveform. This method compensates for high frequency loss in the transmission media that would otherwise limit the magnitude of this waveform. The effects of pre-emphasis are shown in four scope screen captures, [Figure 3-2](#) through [Figure 3-5](#) on the pages following.

The STRONG notation in [Figure 3-3](#) is used to show that the waveform is greater in voltage magnitude, at this point, than the LOGIC or normal level (i.e., no pre-emphasis).

A second characteristic of RocketIO transceiver pre-emphasis is that the STRONG level is reduced after some time to the LOGIC level, thereby minimizing the voltage swing necessary to switch the differential pair into the opposite state.

Lossy transmission lines cause the dissipation of electrical energy. This pre-emphasis technique extends the distance that signals can be driven down lossy line media and increases the signal-to-noise ratio at the receiver.

It should be noted that high pre-emphasis settings are not appropriate for short links (a fraction of the maximum length of 40 inches of FR4). Excessive pre-emphasis can actually degrade the bit error rate (BER) of a multi-gigabit link. Careful simulation and/or lab testing of the system should always be used to verify that the optimal pre-emphasis setting is in use. Consult the *Virtex-II Pro RocketIO™ Multi-Gigabit Transceiver Characterization Summary* for more detailed information on the waveforms to be expected at the various pre-emphasis levels.

The four levels of pre-emphasis are shown in [Table 3-2](#).

Table 3-2: Pre-emphasis Values

Attribute Values	Emphasis (%)
0	10
1	20
2	25
3	33

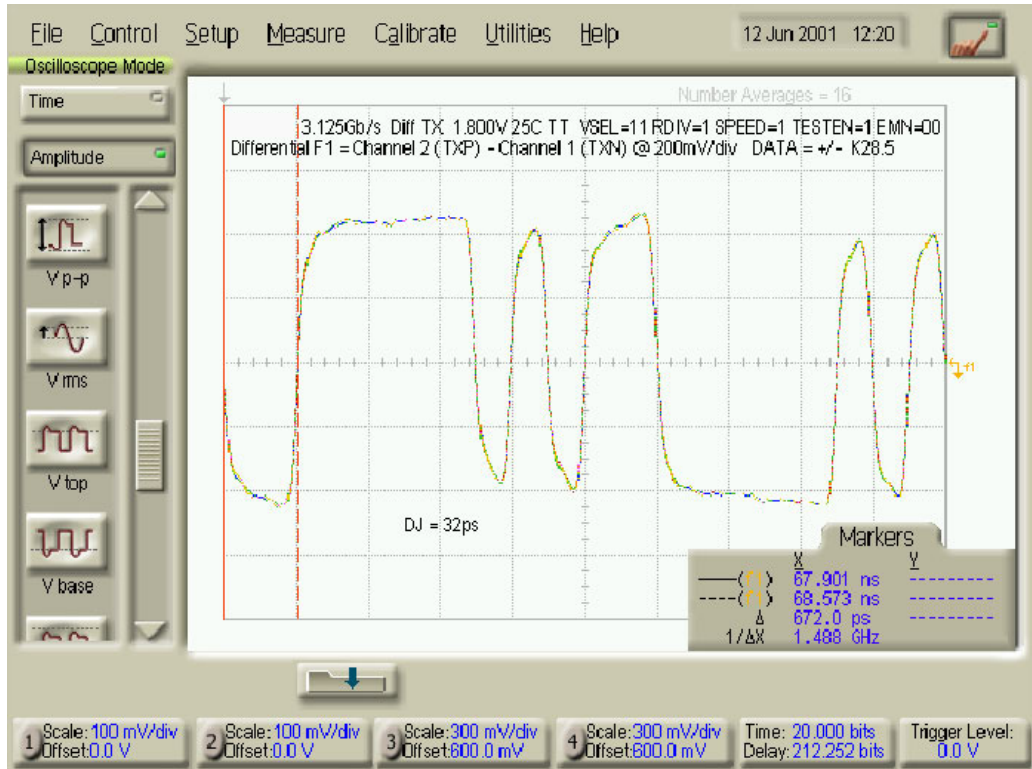

UG024_17_020802

Figure 3-2: Alternating K28.5+ with No Pre-Emphasis

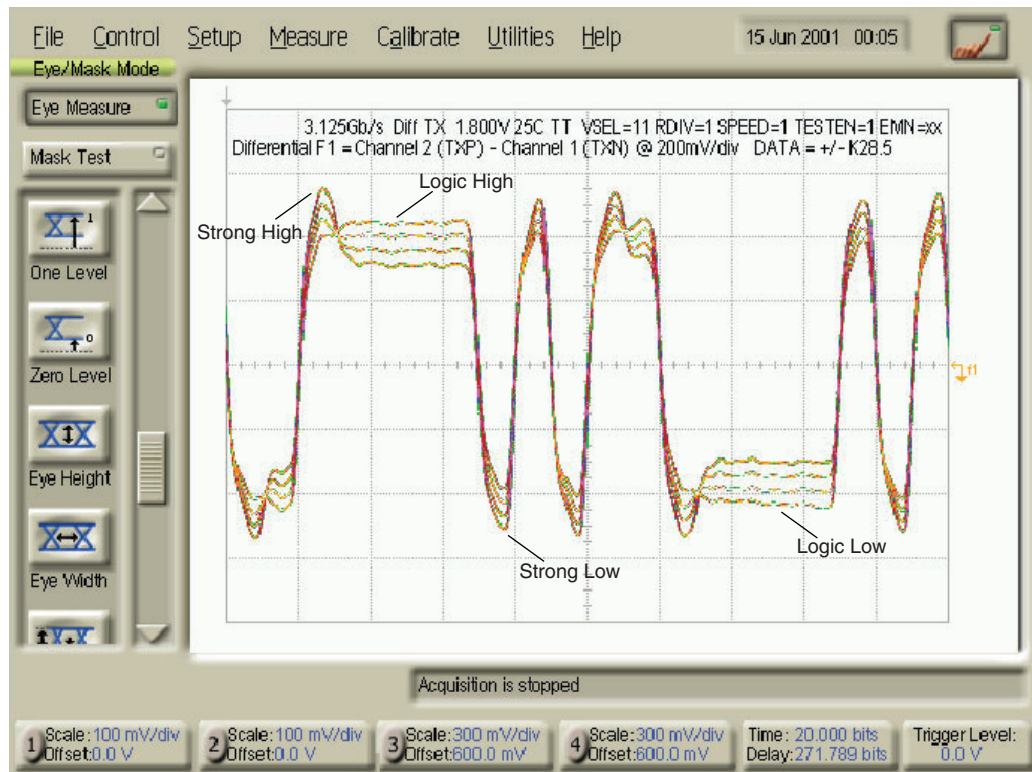

UG024_18_020802

Figure 3-3: K28.5+ with Pre-Emphasis

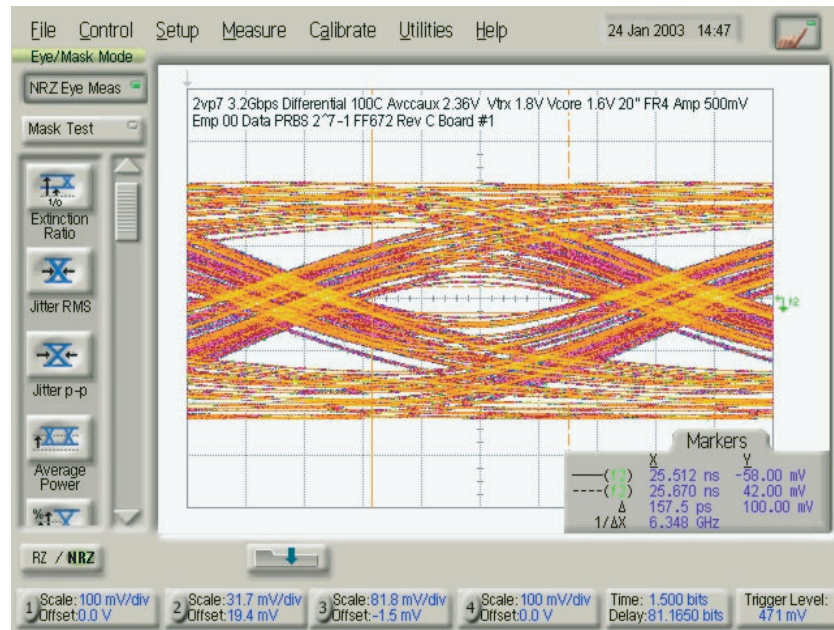

ug024_36_031803

Figure 3-4: Eye Diagram, 10% Pre-Emphasis, 20" FR4, Worst-Case Conditions

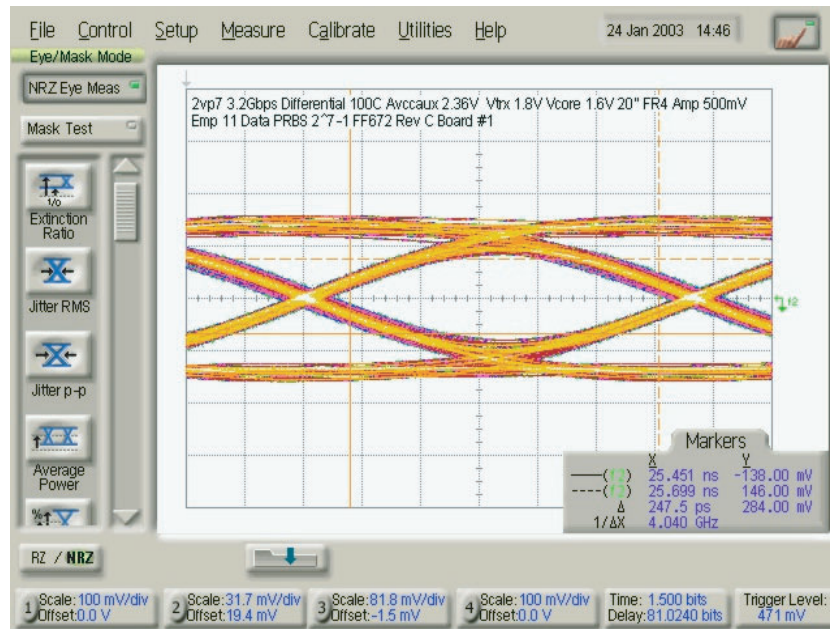

ug024_37_031803

Figure 3-5: Eye Diagram, 33% Pre-Emphasis, 20" FR4, Worst-Case Conditions

Differential Receiver

The differential receiver accepts the V_P and V_N signals, carrying out the difference calculation $V_P - V_N$ electronically.

All input data must be differential and nominally biased to a common mode voltage of 0.5 V – 2.5 V, or AC coupled. Internal terminations provide for simple 50Ω or 75Ω transmission line connection. See [Figure 3-6](#).

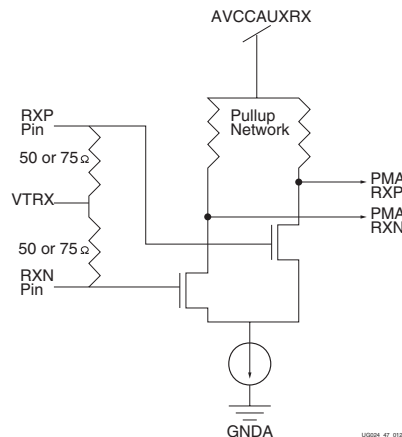

Figure 3-6: MGT Receiver

The differential receiver parameters are shown in [Table 3-3](#).

Table 3-3: Differential Receiver Parameters

Parameter		Min	Typ	Max	Units	Conditions
V_{IN}	Serial input differential peak to peak (RXP/RXN)	175		2000	mV	
V_{ICM}	Common mode input voltage range	500		2500	mV	
T_{ISKEW}	Differential input skew			75	ps	
T_{JTOL}	Receive data total jitter tolerance (peak to peak)			0.65	UI ⁽¹⁾	
T_{DJTOL}	Receive data deterministic jitter tolerance (peak to peak)			0.41	UI	

Notes:

1. UI = Unit Interval

Jitter

Jitter is defined as the short-term variations of significant instants of a signal from their ideal positions in time (ITU). Jitter is typically expressed in a decimal fraction of Unit Interval (UI), e.g. 0.3 UI.

$$\text{Total Jitter} = \text{Deterministic Jitter (DJ)} + \text{Random Jitter (RJ)}$$

Deterministic Jitter (DJ) is data pattern dependant jitter, attributed to a unique source (e.g., Inter Symbol Interference (ISI) due to loss effects of the media). DJ is linearly additive.

Random Jitter (RJ) is due to stochastic sources, such as substrate, power supply, etc. RJ is additive as the sum of squares, and follows a bell curve.

Clock and Data Recovery

The serial transceiver input is locked to the input data stream through Clock and Data Recovery (CDR), a built-in feature of the RocketIO transceiver. CDR keys off the rising and falling edges of incoming data and derives a clock that is representative of the incoming data rate.

The derived clock, RXRECCLK, is presented to the FPGA fabric at 1/20th the incoming data rate (whether full-rate or half-rate). This clock is generated and remains locked as long as it remains within the specified component range. This range is shown in [Table 3-4](#).

A sufficient number of transitions must be present in the data stream for CDR to work properly. The CDR circuit is guaranteed to work with 8B/10B encoding. Further, CDR requires approximately 5,000 transitions upon power-up to guarantee locking to the incoming data rate. Once lock is achieved, up to 75 missing transitions can be tolerated before lock to the incoming data stream is lost.

Table 3-4: CDR Parameters

Parameter		Min	Typ	Max	Units	Conditions
Frequency Range	Serial input, diff. (RXP/RXN)	300		1,562.5	MHz	
TDCREF	REFCLK ⁽¹⁾ duty cycle	45	50	55	%	
TRCLK/TFCLK	REFCLK ⁽¹⁾ rise and fall time (see Virtex-II Pro Data Sheet, Module 3)		600	1000	ps	Between 20% and 80% voltage levels
TGJTT	REFCLK ⁽¹⁾ total jitter, ⁽²⁾ peak-to-peak			40	ps	3.125 Gb/s
				50	ps	2.5 Gb/s
				120	ps	1.06 Gb/s
TLOCK ⁽³⁾	Clock recovery frequency acquisition time			10	μs	From system reset. Much less time is needed to lock if loss of sync occurs (T _{phase}), which is described in Data Sheet Module 3.
TUNLOCK					cycles	
	PLL length			75	non-transitions	Requirement when bypassing 8B/10B

Notes:

1. BREFCLK for speeds of 2.5 Gb/s or greater.
2. Jitter measured at BGA ball.
3. T_{LOCK} depends on serial speed and length/type of sequence used.

An additional feature of CDR is its ability to accept an external precision clock, REFCLK, which either acts to clock incoming data or to assist in synchronizing the derived RXRECCLK.

For further clarity, TXUSRCLK is used to clock data from the FPGA core to the TX FIFO. The FIFO depth accounts for the slight phase difference between these two clocks. If the clocks are locked in frequency, then the FIFO acts much like a pass-through buffer.

PCB Design Requirements

To ensure reliable operation of the RocketIO transceivers, certain requirements must be met by the designer. This section outlines these requirements governing power filtering networks, high-speed differential signal traces, and reference clocks. Any designs that do not adhere to these requirements will not be supported by Xilinx, Inc.

Power Conditioning

Each RocketIO transceiver has five power supply pins, all of which are sensitive to noise. [Table 3-5](#) summarizes the power supply pins, their names, and associated voltages. For power and current requirements of each supply, refer to the data sheet ([DS083](#)).

To operate properly, the RocketIO transceiver requires a certain level of noise isolation from surrounding noise sources. For this reason, it is required that both dedicated voltage regulators and passive high-frequency filtering be used to power the RocketIO circuitry.

Table 3-5: Transceiver Power Supply Ranges

Supply	2.5V ±5%	1.8V - 2.625V	1.6V - 1.8V	Description
AVCCAUXRX	√			Analog RX supply
AVCCAUTX	√			Analog TX supply
VTRX ⁽¹⁾		√	√	RX termination supply
VTTX ⁽²⁾		√		TX termination supply
GND A				Analog ground for transmit and receive analog supplies

Notes:

1. See section “AC and DC Coupling,” page 117, and [Table 3-8](#) for VTRX supply restrictions in AC- and DC-coupled cases.
2. Pre-emphasis and swing settings are optimal at VTTX = 2.5V ±5%. VTTX can be powered with as low as 1.8V in applications with data rates below 1.25 Gb/s (LVDS interfacing). Contact your Xilinx FAE for more information on such interfaces.

Voltage Regulator Selection and Use

Xilinx has qualified a number of linear regulators for use with RocketIO transceivers. RocketIO supplies must be powered by voltage regulators meeting the following criteria:

- Must be a linear or LDO regulator (switching or DC/DC converter is not acceptable).
- Must be used in the circuit given in [Figure 3-7](#).
- Must either be a qualified linear regulator listed in [Table 3-6](#) or meet the following criteria:

- ◆ Output noise no greater than 40 μV RMS from 10 Hz to 100 kHz
- ◆ Regulation to within 2% of nominal output voltage (± 50 mV for 2.5V supply)

Table 3-6: Qualified Linear Regulators

Vendor	Part Number	Current Rating	Description
Linear Technology	LT1963	1.5A	Low-Noise LDO Regulator
Linear Technology	LT1764	3.0A	Low Noise LDO Regulator
Texas Instruments	TPS795xx	0.5A	RF LDO Regulator
Texas Instruments	TPS796xx	1.0A	RF LDO Regulator
Texas Instruments	TPS786xx	1.5A	RF LDO Regulator
National Semiconductor	LP3875	1.5A	Ultra LDO Regulator

Voltage regulators in this category typically are available in both fixed and adjustable output varieties. Those with fixed output voltage require no output adjustment resistors, whereas adjustable versions require a two resistor voltage divider to determine the output voltage. See vendor data to select these resistors and for information on connection of all other regulator pins (Sense, Shutdown, etc.).

Vendor application examples typically recommend a 10 μF capacitor on the input and a 10 μF capacitor on the output of the regulator. For use with RocketIO transceivers, Xilinx requires that this be modified according to the capacitor topology shown in Figure 3-7. The 10 μF capacitor on the input is not changed. However, the 10 μF output capacitor is replaced with one 330 μF capacitor and eight 1.0 μF capacitors. In cases where more than 16 MGTs are powered from a single regulator, an additional 1.0 μF capacitor is required for every two additional MGTs. Tantalum is the recommended capacitor type for the 330 μF capacitor, though the low-ESR electrolytic type is also acceptable. X7R or X5R ceramic is the recommended capacitor type for the 1.0 μF and 10 μF capacitors. These capacitors can be placed anywhere on the board, but preferably in close proximity to the regulator.

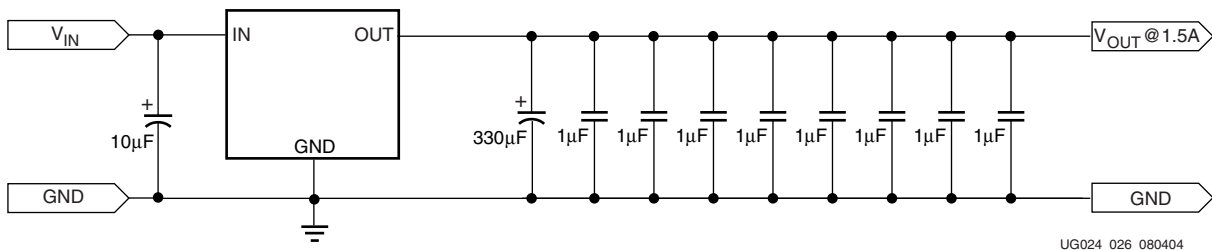

Figure 3-7: Power Supply Circuit Using Approved Regulator

Termination Voltage

Termination voltages V_{TTX} and V_{TRX} can be of any value in the range of 1.8V to 2.625V (V_{TTX}) or 1.6V to 2.525 V (V_{TRX}). In cases where the RocketIO transceiver is interfacing

with a transceiver from another vendor, termination voltage can be dictated by the specifications of the other transceiver. In cases where the RocketIO transceiver is interfacing with another RocketIO transceiver, any termination voltage can be used. With AVCCAUTX and AVCCAURX already powered with 2.5V, an obvious choice for VTTX and VTRX is 2.5V. However, it should be noted that when AC coupling is used, the optimum value for VTRX is 1.7V. See “AC and DC Coupling” section for more information.

Passive Filtering

To achieve the necessary isolation from high-frequency power supply noise, passive filter networks are required on the power supply pins. Figure 3-8 illustrates the difference in power filtering networks between a device that does contain capacitors (Internal) and a device that does not contain capacitors (External).

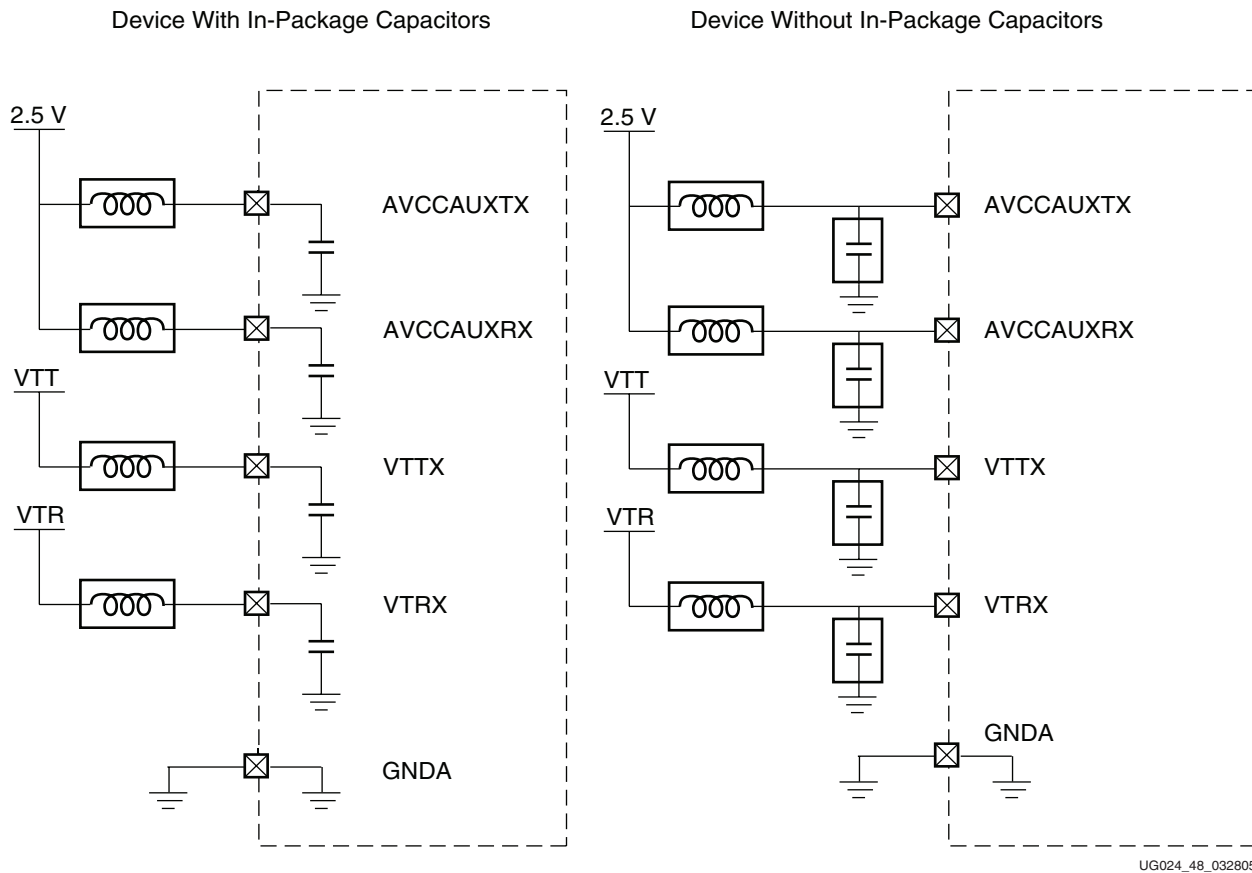

Figure 3-8: Power Filtering Network on Devices with Internal & External Capacitors

Each transceiver power pin requires one capacitor and one ferrite bead. The capacitors must be of value 0.22 μ F in an 0603 (EIA) SMT package of X7R or X5R dielectric material at 15% tolerance, rated to at least 5 V. The ferrite bead is either the Murata BLM18AG102SN1 or the Murata BLM15AG102SNID. These components may not be shared among multiple RocketIO power supply pins under any circumstances.

Many of the Virtex-II Pro devices have power filtering capacitors incorporated into the package to reduce component count on the PCB and improve the effectiveness of these capacitors. Table 3-7 outlines which device/package combinations have 0.22 μ F capacitors internal to the package and which devices do not. External ferrite beads must be used in all

cases, as ferrite beads are not included inside the package in any device. Table boxes labeled “External” denote a device for which the user must provide power filtering capacitors externally on the PCB; those labeled “Internal” denote a device that contains all necessary 0.22 μ F capacitors for RocketIO power pins. Table boxes that say “No MGTs” denote a device that does not have any RocketIO transceivers.

Table 3-7: Device and Package Combinations showing Devices with RocketIO Power Filtering Capacitors Internal to the Package and Externally Mounted on the PCB

	XC2VP2	XC2VP4	XC2VP7	XC2VP20	XC2VP30	XC2VP40	XC2VP50	XC2VP70	XC2VP100
FG256	External	External							
FG456	External	External	External						
FF672	Internal	Internal	Internal						
FG676				External	External	External			
FF896			Internal	Internal	Internal				
FF1152				Internal	Internal	Internal	Internal		
FF1148						No MGTs	No MGTs		
FF1517						Internal	Internal	Internal	
FF1704								Internal	Internal
FF1696									No MGTs

For devices that do not contain filtering capacitors in their package, the 0.22 μ F capacitors must be placed within 1 cm of the pins they are connected to.

[Figure 3-9](#), [Figure 3-10](#), and [Figure 3-11](#) show example layouts of the power filtering network for four transceivers (in one case in a package with internal capacitors, in another case in a package with external capacitors).

The device in [Figure 3-9](#) is in an FF672 package, which has eight transceivers total—four on the top edge (rows A/B), and four on the bottom edge (rows AE/AF). This device contains internal capacitors, so it is only necessary to have ferrite beads on the PCB. [Figure 3-9](#) shows the bottom PCB layer, with lands for ferrite beads of the VTTX, VTRX,

AVCCAUXTX, and AVCCAUXRX supplies. The ferrite beads are mounted at the sixteen “L[n]” locations.

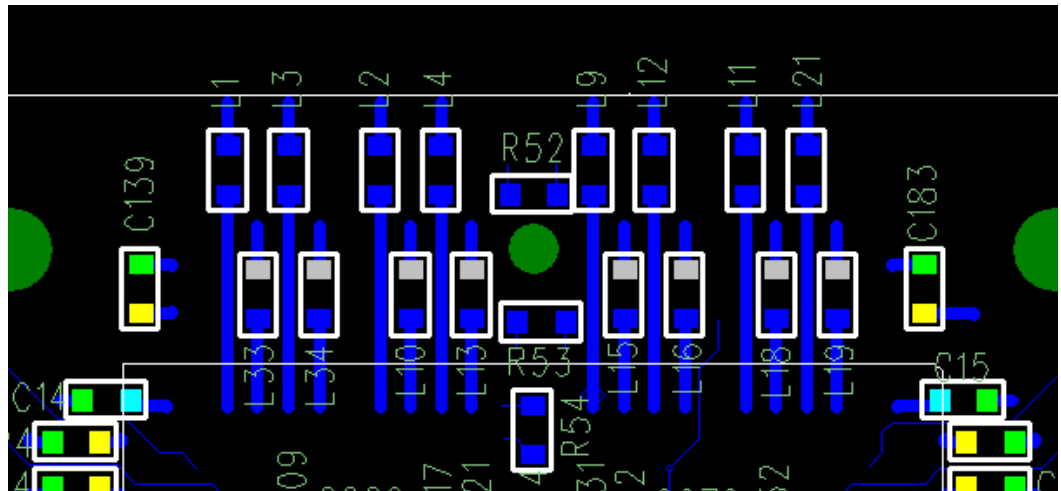

Figure 3-9: Example Power Filtering PCB Layout for Four MGTs, in Device with Internal Capacitors, Bottom Layer

The device in [Figure 3-10](#) and [Figure 3-11](#) is an FG456 package, which also has eight transceivers total – four on the top edge, and four on the bottom edge. This device does not have capacitors inside the package, so it is necessary to have both capacitors and ferrite beads mounted on the PCB. [Figure 3-10](#) shows the top PCB layer, with lands for the capacitors and ferrite beads of the VTTX and VTRX supplies. [Figure 3-11](#) shows the bottom PCB layer, with lands for the capacitors and ferrite beads of the AVCCAUXTX and AVCCAUXRX supplies. The ferrite beads are mounted at the eight “L[n]” locations; the capacitors are mounted at the eight “C[n]” locations.

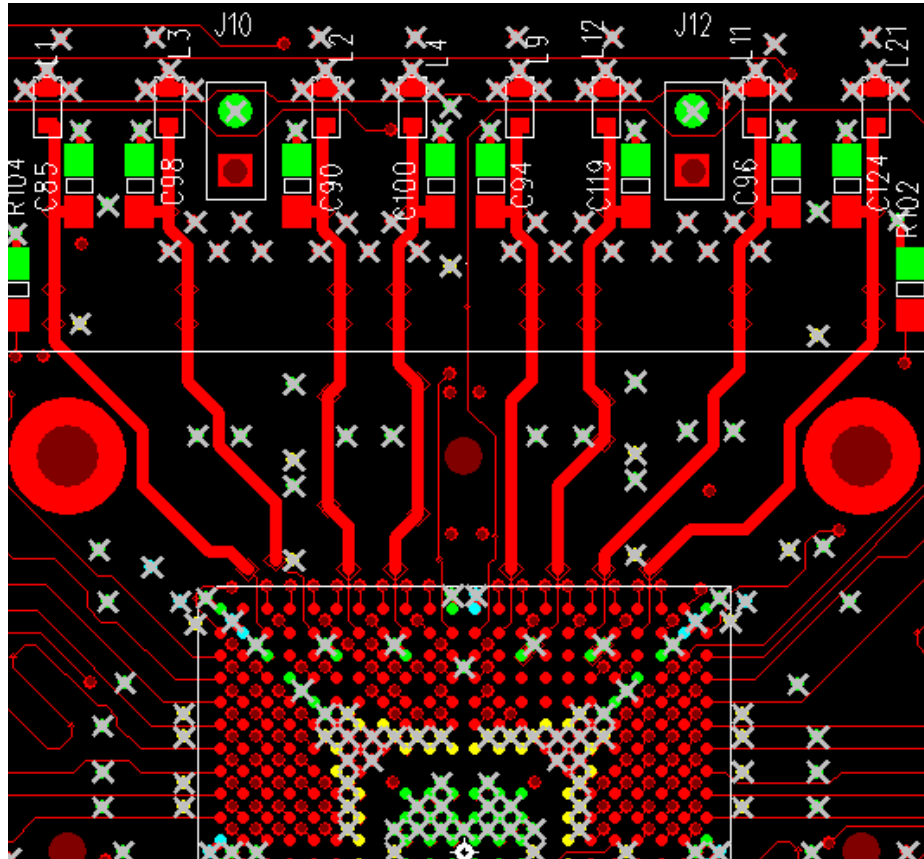

Figure 3-10: Example Power Filtering PCB Layout for Four MGTs, In Device with External Capacitors, Top Layer

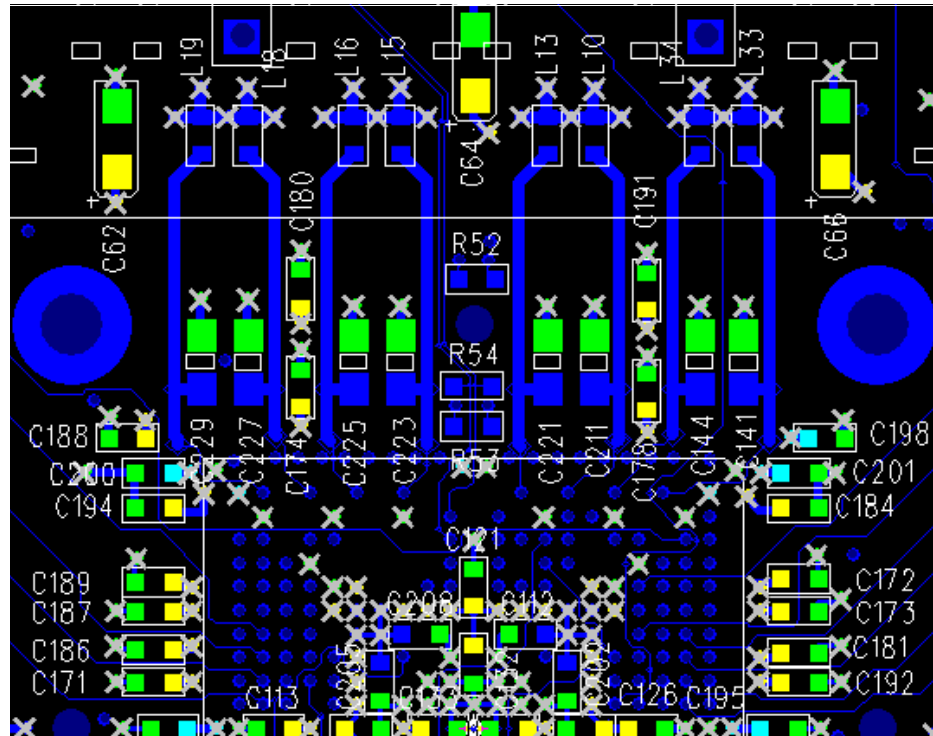

Figure 3-11: Example Power Filtering PCB Layout for Four MGTs, in Device with External Capacitors, Bottom Layer

High-Speed Serial Trace Design

Routing Serial Traces

All RocketIO transceiver I/Os are placed on the periphery of the BGA package to facilitate routing and inspection (since JTAG is not available on serial I/O pins). Two output/input impedance options are available in the RocketIO transceivers: 50Ω and 75Ω. Controlled impedance traces with a corresponding impedance should be used to connect the RocketIO transceiver to other compatible transceivers. In chip-to-chip PCB applications, 50Ω termination and 100Ω differential transmission lines are recommended.

When routing a differential pair, the complementary traces must be matched in length to as close a tolerance as is feasible. Length mismatches produce common mode noise and radiation. Severe length mismatches produce jitter and unpredictable timing problems at the receiver. Matching the differential traces to within 50 mils (1.27 mm) produces a robust design. Since signals propagate in FR4 PCB traces at approximately 180 ps per inch, a difference of 50 mils produces a timing skew of roughly 9 ps. Use SI CAD tools to confirm these assumptions on specific board designs.

All signal traces must have an intact reference plane beneath them. Stripline and microstrip geometries may be used. The reference plane should extend no less than five trace widths to either side of the trace to ensure predictable transmission line behavior.

Routing of a differential pair is optimally done in a point-to-point fashion, ideally remaining on the same PCB routing layer. As vias represent an impedance discontinuity, layer-to-layer changes should be avoided wherever possible. It is acceptable to traverse the PCB stackup to reach the transmitter and receiver package pins. If serial traces must change layers, care must be taken to ensure an intact current return path. For this reason,

routing of high-speed serial traces should be on signal layers that share a reference plane. If the signal layers do not share a reference plane, a capacitor of value 0.01 μF should be connected across the two reference layers close to the vias where the signals change layers. If both of the reference layers are DC coupled (if they are both ground), they can be connected with vias close to where the signals change layers.

To control crosstalk, serial differential traces should be spaced at least five trace separation widths from all other PCB routes, including other serial pairs. A larger spacing is required if the other PCB routes carry especially noisy signals, such as TTL and other similarly noisy standards.

The RocketIO transceiver is designed to function at 3.125 Gb/s through 40 inches of PCB with two high-bandwidth connectors. Longer trace lengths require either a low-loss dielectric or considerably wider serial traces.

Differential Trace Design

The characteristic impedance of a pair of differential traces depends not only on the individual trace dimensions, but also on the spacing between them. The RocketIO transceivers require either a 100 Ω or 150 Ω differential trace impedance (depending on whether the 50 Ω or 75 Ω termination option is selected). To achieve this differential impedance requirement, the characteristic impedance of each individual trace must be slightly higher than half of the target differential impedance. A field solver should be used to determine the exact trace geometry suited to the specific application (Figure 3-12). This task should not be left up to the PCB vendor.

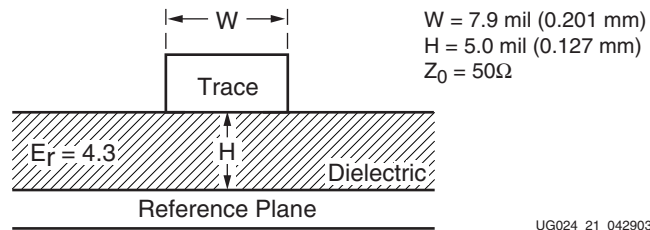

Figure 3-12: Single-Ended Trace Geometry

Trace lengths up to 20" in FR4 may be of any width, provided that the differential impedance is 100 Ω or 150 Ω . Trace lengths between 20" and 40" in FR4 must be at least 8 mils wide and have a differential impedance of 100 Ω or 150 Ω . For information on other dielectric materials, please contact your Xilinx representative or the Xilinx Hotline.

Differential impedance of traces on the finished PCB should be verified with Time Domain Reflectometry (TDR) measurements.

Tight coupling of differential traces is recommended. Tightly coupled traces (as opposed to loosely coupled) maintain a very close proximity to one another along their full length. Since the differential impedance of tightly coupled traces depends heavily on their proximity to each other, it is imperative that they maintain constant spacing along their full length, without deviation. If it is necessary to separate the traces in order to route through a pin field or other PCB obstacle, it can be helpful to modify the trace geometry in the vicinity of the obstacle to correct for the impedance discontinuity (increase the individual trace width where trace separation occurs). Figure 3-13 and Figure 3-14 show examples of PCB geometries that result in 100 Ω differential impedance.

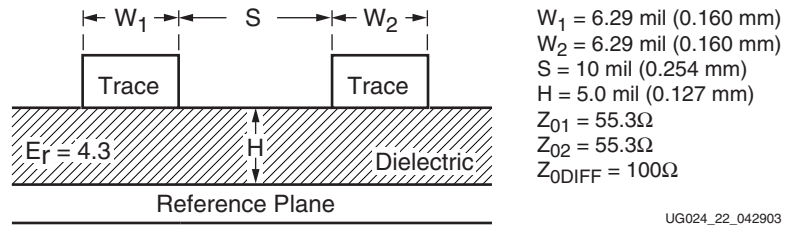

Figure 3-13: Microstrip Edge-Coupled Differential Pair

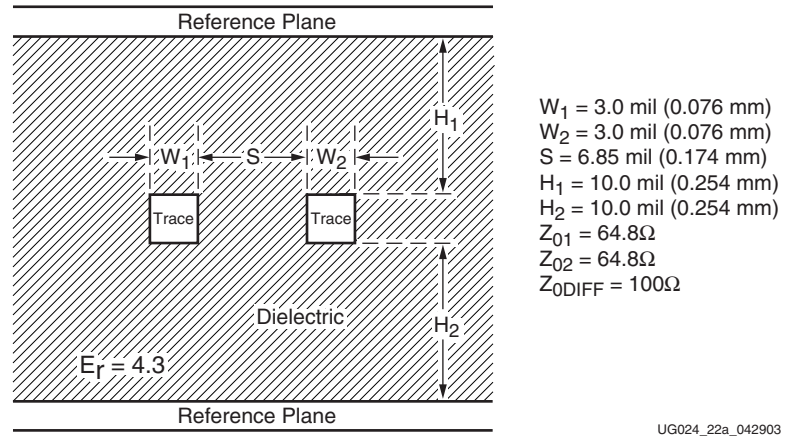

Figure 3-14: Stripline Edge-Coupled Differential Pair

AC and DC Coupling

AC coupling (use of DC blocking capacitors in the signal path) should be used in cases where transceiver differential voltages are compatible, but common mode voltages are not. Some designs require AC coupling to accommodate hot plug-in, and/or differing power supply voltages at different transceivers. This is illustrated in Figure 3-15.

Capacitors of value 0.01 μF in a 0402 (EIA) package are suitable for AC coupling at 3.125 Gb/s when 8B/10B encoding is used. Different data rates and different encoding schemes may require a different value.

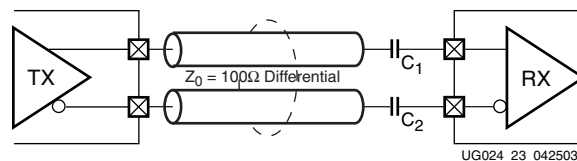

Figure 3-15: AC-Coupled Serial Link

DC coupling (direct connection) is preferable in cases where RocketIO transceivers are interfaced with other RocketIO transceivers or other Mindspeed transceivers that have compatible differential and common mode voltage specifications. Passive components are not required when DC coupling is used. This is illustrated in Figure 3-16.

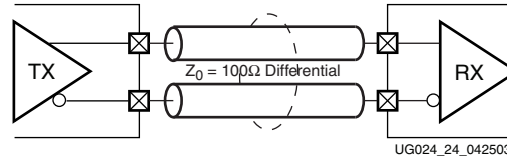

Figure 3-16: DC-Coupled Serial Link

The RocketIO differential receiver produces the best bit-error rates when its common-mode voltage falls between 1.6V and 1.8V. When the receiver is AC-coupled to the line, V_{TRX} is the sole determinant of the receiver common-mode voltage, and therefore must be set to a value within this range. When two transceivers, both terminated with 2.5V, are DC-coupled, the common-mode voltage will establish itself at around 1.7V to 1.8V.

The V_{TRX} and V_{TTX} voltages for different coupling environments are summarized in [Table 3-8](#).

Table 3-8: Recommended V_{TRX} and V_{TTX} for AC- and DC-Coupled Environments

Coupling	V_{TRX}	V_{TTX}
AC	1.6V to 1.8V	2.5V \pm 5%
DC	2.5V \pm 5% ⁽¹⁾	2.5V \pm 5% ⁽¹⁾

Notes:

1. The recommended voltage for DC-coupled implementations is 2.5V. However, any voltage is valid as long as both V_{TRX} and V_{TTX} are the same voltage, and within the specifications shown in [Table 3-5, page 109](#).

Reference Clock

A high degree of accuracy is required from the reference clock. For this reason, it is required that one of the oscillators listed in this section be used:

Epson EG-2121CA 2.5V (LVPECL Outputs)

See the [Epson Electronics America website](#) for detailed information. The power supply circuit specified by the manufacturer must be used.

The circuit shown in [Figure 3-17](#) must be used to interface the oscillator's LVPECL outputs to the LVDS or LVPECL inputs of the transceiver reference clock. Alternatively, the LVDS_25_DT input buffers can be used to terminate the signals on-chip, as shown in [Figure 3-18](#).

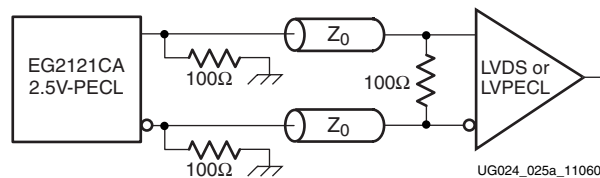

Figure 3-17: LVPECL Reference Clock Oscillator Interface

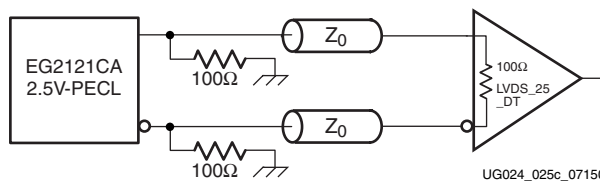

Figure 3-18: LVPECL Reference Clock Oscillator Interface (On-Chip Termination)

Pletronics LV1145B (LVDS Outputs)

See the [Pletronics website](#) for detailed information.

The circuit shown in [Figure 3-19](#) must be used to interface the oscillator's LVDS outputs to the LVDS inputs of the transceiver reference clock. Alternatively, the LVDS_25_DT input buffer may be used to terminate the signals on-chip, as shown in [Figure 3-20](#).

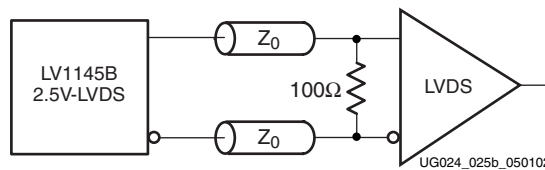

Figure 3-19: LVDS Reference Clock Oscillator Interface

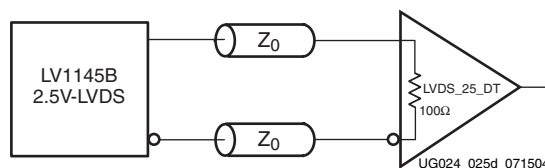

Figure 3-20: LVDS Reference Clock Oscillator Interface (On-Chip Termination)

Other Important Design Notes

Powering the RocketIO Transceivers

IMPORTANT! All RocketIO transceivers in the FPGA, whether instantiated in the design or not, must be connected to power and ground. Unused transceivers may be powered by any 2.5 V source, and passive filtering is not required.

The maximum power consumption per port is 350 mW at 3.125 Gb/s operation.

Pin Connections on the Unused RocketIO Transceivers

When the Entire MGT Is Unused

- The TXP/TXN and RXP/RXN pins must be left unconnected.
- The AVCCAUXRX and AVCCAUTX pins must be connected to a 2.5V supply, but that supply does not need a linear regulator or filter network.
- The VTTX and VTRX pins must be connected to a 2.5V supply, but that supply does not need a linear regulator or filter network.
- GNDA must be connected to ground.

When Only Part of the MGT Is Used

This could occur, for example, if the MGT is used as a TX or an RX, but not both.

- Both AVCCAUXRX and AVCCAUTX must be connected to power with passive filtering.
- GNDA must be connected to ground.
- Both VTTX and VTRX must be connected to power with passive filtering.

The unused TX or RX pins can be unconnected. If the MGT is used as a receiver, the TX pins can be left unconnected. If the design uses the transmitter, the RX pins can safely be left unconnected, and oscillations will not cause erroneous behavior because the termination resistors (50Ω or 75Ω) act as pull-ups on the line.

The POWERDOWN Port

POWERDOWN is a single-bit primitive port (see [Table 2-5, page 43](#)) that allows shutting off the transceiver in case it is not needed for the design, or will not be transmitting or receiving for a long period of time. When POWERDOWN is asserted, the transceiver does not use any power. The clocks are disabled and do not propagate through the core. The 3-state TXP and TXN pins are set High-Z, while the outputs to the fabric are frozen but *not* set High-Z.

Any given transceiver that is *not* instantiated in the design will automatically be set to the POWERDOWN state by the Xilinx ISE development software, and will consume no power. An instantiated transceiver, however, will consume some power, even if it is not engaged in transmitting or receiving. Therefore, when a transceiver is not to be used for an extended period of time, the POWERDOWN port should be asserted High to reduce overall power consumption by the Virtex-II Pro FPGA.

Deasserting the POWERDOWN port restores the transceiver to normal functional status. When POWERDOWN is toggled, the PMA is properly initialized.



Simulation and Implementation

Simulation Models

SmartModels

SmartModels are encrypted versions of the actual HDL code. These models allow the user to simulate the actual functionality of the design without having access to the code itself. A simulator with SmartModel capability is required to use SmartModels.

The models must be extracted before they can be used. For information on how to extract the SmartModels under ISE 5.1i, see [Solution Record 15501](#).

HSPICE

HSPICE is an analog design model that allows simulation of the RX and TX high-speed transceiver. To obtain these HSPICE models, go to the Xilinx Download Center at:

http://www.xilinx.com/xlnx/xil_sw_updates_home.jsp.

Select **HSPICE and Eldo Models** and then **Virtex-II Pro** from the pull-down menus. Online registration is required. Follow the instructions on the web page to register.

Implementation Tools

Par

For place and route, the transceiver has one restriction. This is required when channel bonding is implemented. Because of the delay limitations on the CHBONDO to CHBONDI ports, linking of the Master to a Slave_1_hop must run either in the X or Y direction, but not both.

In [Figure 4-1](#), the two Slave_1_hops are linked to the master in only one direction. To navigate to the other slave (a Slave_2_hops), both X and Y displacement is needed. This slave needs one level of daisy-chaining, which is the basis of the Slave_2_hops setting.

[Figure 4-2](#) shows the channel bonding mode and linking for a 2VP50, which (optionally) contains more transceivers (16) per chip.

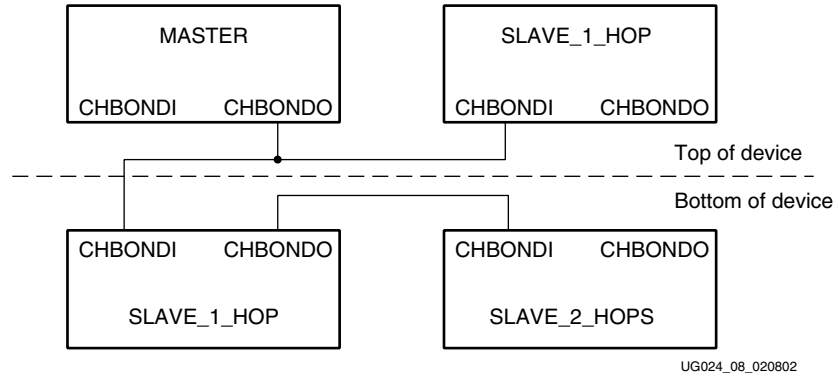

Figure 4-1: XC2VP2 Implementation

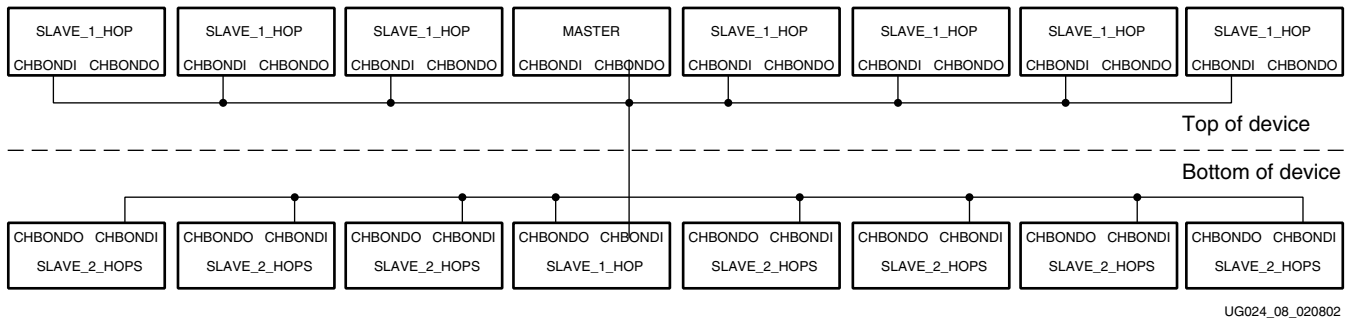

Figure 4-2: XC2VP50 Implementation

MGT Package Pins

The MGT is a hard core placed in the FPGA fabric; all package pins for the MGTs are dedicated on the Virtex-II Pro device. This is shown in the package pin diagrams in the [Virtex-II Pro Platform FPGA User Guide](#). When creating a design, LOC constraints must be used to implement a specific MGT on the die. This LOC constraint also determines which package pins are used. [Table 4-1](#) shows the correlation between the LOC grid and the package pins themselves. The pin numbers are TXNPAD, TXPPAD, RXPPAD, and RXNPAD, respectively. The power pins are adjacent to these pins in the package pin diagrams of the *User Guide*.

Table 4-1: LOC Grid & Package Pins Correlation for FG256/456 & FF672

LOC Constraints	FG256	FG456		FF672	
	2VP2/2VP4	2VP2/2VP4	2VP7	2VP2/2VP4	2VP7
GT_X0_Y0	T4, T5, T6, T7	AB7, AB8, AB9, AB10	AB3, AB4, AB5, AB6	AF18, AF17, AF16, AF15	AF23, AF22, AF21, AF20
GT_X0_Y1	A4, A5, A6, A7	A7, A8, A9, A10	A3, A4, A5, A6	A18, A17, A16, A15	A23, A22, A21, A20
GT_X1_Y0	T10, T11, T12, T13	AB13, AB14, AB15, AB16	AB7, AB8, AB9, AB10	AF12, AF11, AF10, AF9	AF18, AF17, AF16, AF15
GT_X1_Y1	A10, A11, A12, A13	A13, A14, A15, A16	A7, A8, A9, A10	A12, A11, A10, A9	A18, A17, A16, A15
GT_X2_Y0			AB13, AB14, AB15, AB16		AF12, AF11, AF10, AF9
GT_X2_Y1			A13, A14, A15, A16		A12, A11, A10, A9
GT_X3_Y0			AB17, AB18, AB19, AB20		AF7, AF6, AF5, AF4
GT_X3_Y1			A17, A18, A19, A20		A7, A6, A5, A4

Table 4-2: LOC Grid & Package Pins Correlation for FG676, FF896, and FF1152

LOC Constraints	FG676		FF896		FF1152		
	2VP20 /2VP30	2VP40	2VP7 /2VP20	2VP30	2VP20 /2VP30	2VP40	2VP50
GT_X0_Y0	AF7, AF6, AF5, AF4		AK27, AK26, AK25, AK24	AK27, AK26, AK25, AK24	AP29, AP28, AP27, AP26	AP33, AP32, AP31, AP30	AP33, AP32, AP31, AP30
GT_X0_Y1	A7, A6, A5, A4		A27, A26, A25, A24	A27, A26, A25, A24	A29, A28, A27, A26	A33, A32, A31, A30	A33, A32, A31, A30
GT_X1_Y0	AF12, AF11, AF10, AF9	AF7, AF6, AF5, AF4	AK20, AK19, AK18, AK17	AK20, AK19, AK18, AK17	AP21, AP20, AP19, AP18	AP29, AP28, AP27, AP26	AP29, AP28, AP27, AP26
GT_X1_Y1	A12, A11, A10, A9	A7, A6, A5, A4	A20, A19, A18, A17	A20, A19, A18, A17	A21, A20, A19, A18	A29, A28, A27, A26	A29, A28, A27, A26
GT_X2_Y0	AF18, AF17, AF16, AF15	AF12, AF11, AF10, AF9	AK14, AK13, AK12, AK11	AK14, AK13, AK12, AK11	AP17, AP16, AP15, AP14	AP21, AP20, AP19, AP18	AP25, AP24, AP23, AP22
GT_X2_Y1	A18, A17, A16, A15	A12, A11, A10, A9	A14, A13, A12, A11	A14, A13, A12, A11	A17, A16, A15, A14	A21, A20, A19, A18	A25, A24, A23, A22
GT_X3_Y0	AF23, AF22, AF21, AF20	AF18, AF17, AF16, AF15	AK7, AK6, AK5, AK4	AK7, AK6, AK5, AK4	AP9, AP8, AP7, AP6	AP17, AP16, AP15, AP14	AP21, AP20, AP19, AP18
GT_X3_Y1	A23, A22, A21, A20	A18, A17, A16, A15	A7, A6, A5, A4	A7, A6, A5, A4	A9, A8, A7, A6	A17, A16, A15, A14	A21, A20, A19, A18
GT_X4_Y0		AF23, AF22, AF21, AF20				AP9, AP8, AP7, AP6	AP17, AP16, AP15, AP14
GT_X4_Y1		A23, A22, A21, A20				A9, A8, A7, A6	A17, A16, A15, A14
GT_X5_Y0						AP5, AP4, AP3, AP2	AP13, AP12, AP11, AP10
GT_X5_Y1						A5, A4, A3, A2	A13, A12, A11, A10
GT_X6_Y0							AP9, AP8, AP7, AP6
GT_X6_Y1							A9, A8, A7, A6
GT_X7_Y0							AP5, AP4, AP3, AP2
GT_X7_Y1							A5, A4, A3, A2
GT_X8_Y0							
GT_X8_Y1							
GT_X9_Y0							
GT_X9_Y1							

Product Not Recommended for New Designs

Table 4-3: LOC Grid & Package Pins Correlation for FF1517 and FF1704

LOC Constraints	FF1517			FF1704
	2VP40	2VP50	2VP70	2VP70/2VP100
GT_X0_Y0	AW36, AW35, AW34, AW33	AW36, AW35, AW34, AW33	AW36, AW35, AW34, AW33	BB41, BB40, BB39, BB38
GT_X0_Y1	A36, A35, A34, A33	A36, A35, A34, A33	A36, A35, A34, A33	A41, A40, A39, A38
GT_X1_Y0	AW32, AW31, AW30, AW29	AW32, AW31, AW30, AW29		BB37, BB36, BB35, BB34
GT_X1_Y1	A32, A31, A30, A29	A32, A31, A30, A29		A37, A36, A35, A34
GT_X2_Y0	AW24, AW23, AW22, AW21	AW28, AW27, AW26, AW25	AW32, AW31, AW30, AW29	BB33, BB32, BB31, BB30
GT_X2_Y1	A24, A23, A22, A21	A28, A27, A26, A25	A32, A31, A30, A29	A33, A32, A31, A30
GT_X3_Y0	AW19, AW18, AW17, AW16	AW24, AW23, AW22, AW21	AW28, AW27, AW26, AW25	BB29, BB28, BB27, BB26
GT_X3_Y1	A19, A18, A17, A16	A24, A23, A22, A21	A28, A27, A26, A25	A29, A28, A27, A26
GT_X4_Y0	AW11, AW10, AW9, AW8	AW19, AW18, AW17, AW16	AW24, AW23, AW22, AW21	BB25, BB24, BB23, BB22
GT_X4_Y1	A11, A10, A9, A8	A19, A18, A17, A16	A24, A23, A22, A21	A25, A24, A23, A22
GT_X5_Y0	AW7, AW6, AW5, AW4	AW15, AW14, AW13, AW12	AW19, AW18, AW17, AW16	BB21, BB20, BB19, BB18
GT_X5_Y1	A7, A6, A5, A4	A15, A14, A13, A12	A19, A18, A17, A16	A21, A20, A19, A18
GT_X6_Y0		AW11, AW10, AW9, AW8	AW15, AW14, AW13, AW12	BB17, BB16, BB15, BB14
GT_X6_Y1		A11, A10, A9, A8	A15, A14, A13, A12	A17, A16, A15, A14
GT_X7_Y0		AW7, AW6, AW5, AW4	AW11, AW10, AW9, AW8	BB13, BB12, BB11, BB10
GT_X7_Y1		A7, A6, A5, A4	A11, A10, A9, A8	A13, A12, A11, A10
GT_X8_Y0				BB9, BB8, BB7, BB6
GT_X8_Y1				A9, A8, A7, A6
GT_X9_Y0			AW7, AW6, AW5, AW4	BB5, BB4, BB3, BB2
GT_X9_Y1			A7, A6, A5, A4	A5, A4, A3, A2
GT_X10_Y0				
GT_X10_Y1				
GT_X11_Y0				
GT_X11_Y1				



RocketIO Transceiver Timing Model

This appendix explains all of the timing parameters associated with the RocketIO™ transceiver core. It is intended to be used in conjunction with Module 3 of the [Virtex-II Pro Data Sheet](#) and the Timing Analyzer (TRCE) report from Xilinx software. For specific timing parameter values, refer to the data sheet.

There are many signals entering and exiting the RocketIO core. (Refer to [Figure A-1](#).) The model presented in this section treats the RocketIO core as a “black box.” Propagation delays internal to the RocketIO core logic are ignored. Signals are characterized with setup and hold times for inputs, and with clock to valid output times for outputs.

There are five clocks associated with the RocketIO core, but only three of these clocks—RXUSRCLK, RXUSRCLK2, and TXUSRCLK2—have I/Os that are synchronous to them. The following table gives a brief description of all of these clocks. For an in-depth discussion of clocking the RocketIO core, refer to [Chapter 2, “Digital Design Considerations.”](#)

Table A-1: RocketIO Clock Descriptions

CLOCK SIGNAL	DESCRIPTION
REFCLK	Main reference clock for RocketIO transceiver
TXUSRCLK	Clock used for writing the TX buffer. Frequency-locked to REFCLK.
TXUSRCLK2	Clocks transmission data and status and reconfiguration data between the transceiver and the FPGA core. Relationship between TXUSRCLK2 and TXUSRCLK depends on width of transmission data path.
RXUSRCLK	Clock used for reading the RX elastic buffer. Clocks CHBONDI and CHBONO into and out of the transceiver. Typically the same as TXUSRCLK.
RXUSRCLK2	Clocks receiver data and status between the transceiver and the FPGA core. Typically the same as TXUSRCLK2. Relationship between RXUSRCLK2 and RXUSRCLK depends on width of receiver data path.

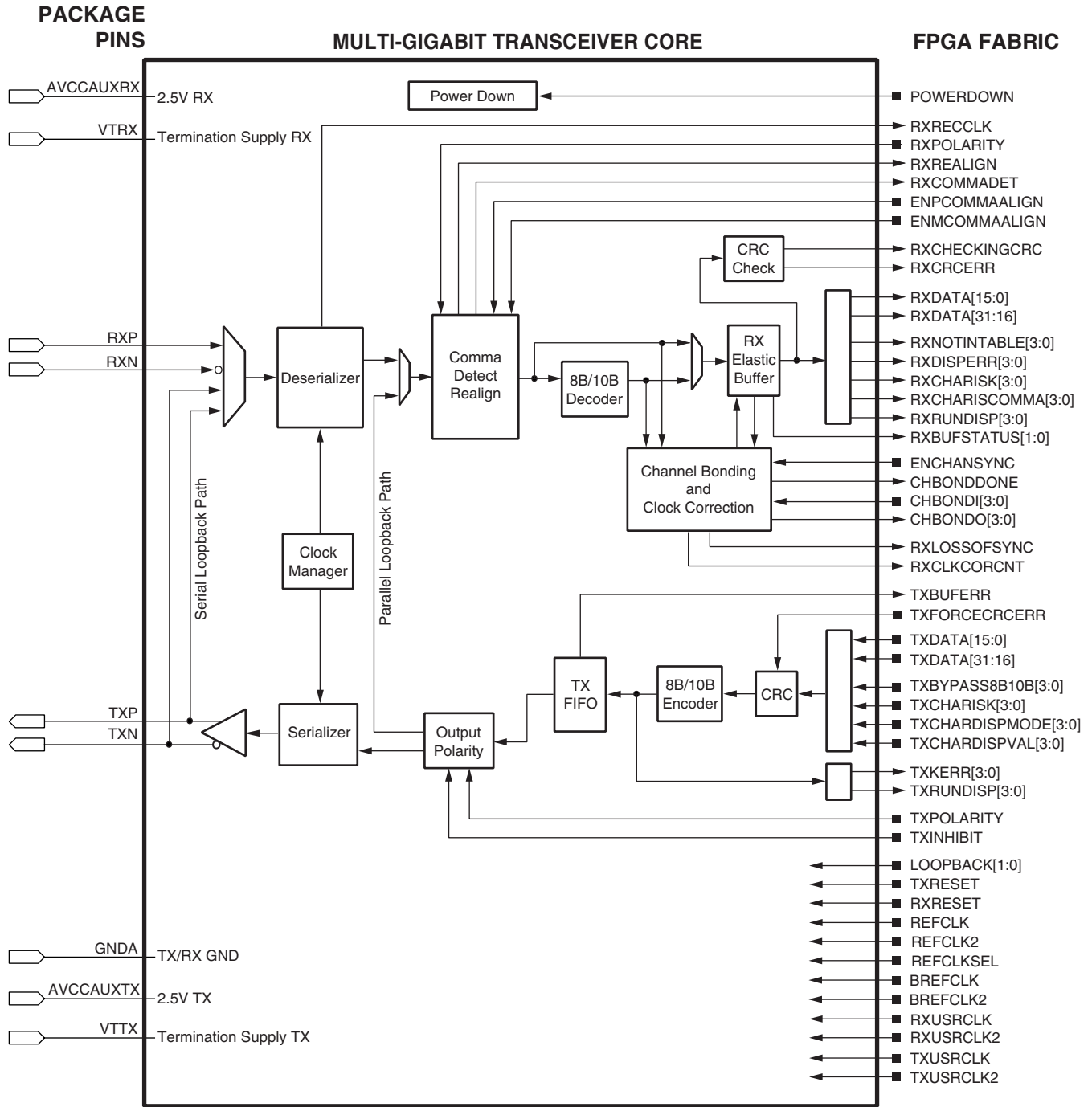

DS083-2_04_090402

Figure A-1: RocketIO Transceiver Block Diagram

Timing Parameters

Parameter designations are constructed to reflect the functions they perform, as well as the I/O signals to which they are synchronous. The following subsections explain the meaning of each of the basic timing parameter designations used in the tables.

Setup/Hold Times of Inputs Relative to Clock

Basic Format:

ParameterName_SIGNAL

where

ParameterName = T with subscript string defining the timing relationship
SIGNAL = name of RocketIO signal synchronous to the clock

ParameterName Format:

T_{GxCK} = Setup time before clock edge
 T_{GCKx} = Hold time after clock edge

where

x = C (Control inputs)
 D (Data inputs)

Setup/Hold Time (Examples):

$T_{GCK_RRST}/T_{GCKC_RRST}$	Setup/hold times of RX Reset input relative to rising edge of RXUSRCLK2
$T_{GDCK_TDAT}/T_{GCKD_TDAT}$	Setup/hold times of TX Data inputs relative to rising edge of TXUSRCLK2

Clock to Output Delays

Basic Format:

ParameterName_SIGNAL

where

ParameterName = T with subscript string defining the timing relationship
SIGNAL = name of RocketIO signal synchronous to the clock

ParameterName Format:

T_{GCKx} = Delay time from clock edge to output

where

x = CO (Control outputs)
 DO (Data outputs)
 ST (Status outputs)

Output Delay Time (Examples):

T_{GCKCO_CHBO}	Rising edge of RXUSRCLK to Channel Bond outputs
T_{GCKDO_RDAT}	Rising edge of RXUSRCLK2 to RX Data outputs
T_{GCKST_TBERR}	Rising edge of TXUSRCLK2 to TX Buffer Err output

Clock Pulse Width

ParameterName Format:

$$T_{xPWH} = \text{Minimum pulse width, High state}$$

$$T_{xPWL} = \text{Minimum pulse width, Low state}$$

where

$$x = \begin{array}{ll} \text{REF} & (\text{REFCLK}) \\ \text{TX} & (\text{TXUSRCLK}) \\ \text{TX2} & (\text{TXUSRCLK2}) \\ \text{RX} & (\text{RXUSRCLK}) \\ \text{RX2} & (\text{RXUSRCLK2}) \end{array}$$

Pulse Width (Examples):

$$T_{TX2PWL} \quad \text{Minimum pulse width, TX2 clock, Low state}$$

$$T_{REFPWH} \quad \text{Minimum pulse width, Reference clock, High state}$$

Timing Parameter Tables and Diagram

The following four tables list the timing parameters as reported by the implementation tools relative to the clocks given in [Table A-1](#), along with the RocketIO signals that are synchronous to each clock. (No signals are synchronous to REFCLK or TXUSRCLK.)

A timing diagram ([Figure A-2](#)) illustrates the timing relationships.

- [Table A-2, "Parameters Relative to the RX User Clock \(RXUSRCLK\)," page 130](#)
- [Table A-3, "Parameters Relative to the RX User Clock2 \(RXUSRCLK2\)," page 131](#)
- [Table A-4, "Parameters Relative to the TX User Clock2 \(TXUSRCLK2\)," page 131](#)
- [Table A-5, "Miscellaneous Clock Parameters," page 132](#)

Table A-2: Parameters Relative to the RX User Clock (RXUSRCLK)

Parameter	Function	Signals
Setup/Hold:		
$T_{GCKC_CHBI}/T_{GCKC_CHBI}$	Control inputs	CHBONDI[3:0]
Clock to Out:		
T_{GCKCO_CHBO}	Control outputs	CHBONDO[3:0]
Clock:		
T_{RXPWH}	Clock pulse width, High state	RXUSRCLK
T_{RXPWL}	Clock pulse width, Low state	RXUSRCLK

Product Not Recommended for New Designs

Table A-3: Parameters Relative to the RX User Clock2 (RXUSRCLK2)

Parameter	Function	Signals
Setup/Hold:		
T _{GCKC} _RRST/T _{GCKC} _RRST	Control input	RXRESET
T _{GCKC} _RPOL/T _{GCKC} _RPOL	Control input	RXPOLARITY
T _{GCKC} _ECSY/T _{GCKC} _ECSY	Control input	ENCHANSYNC
Clock to Out:		
T _{GCKST} _RNIT	Status outputs	RXNOTINTABLE[3:0]
T _{GCKST} _RDERR	Status outputs	RXDISPERR[3:0]
T _{GCKST} _RCMCH	Status outputs	RXCHARISCOMMA[3:0]
T _{GCKST} _ALIGN	Status output	RXREALIGN
T _{GCKST} _CMDT	Status output	RXCOMMADET
T _{GCKST} _RLOS	Status outputs	RXLOSSOFSYNC[1:0]
T _{GCKST} _RCCCNT	Status outputs	RXCLKCORCNT[2:0]
T _{GCKST} _RBSTA	Status outputs	RXBUFSTATUS[1:0]
T _{GCKST} _RCCRC	Status output	RXCHECKINGCRC
T _{GCKST} _RCRCE	Status output	RXRCRERR
T _{GCKST} _CHBD	Status output	CHBONDDONE
T _{GCKST} _RKCH	Status outputs	RXCHARISK[3:0]
T _{GCKST} _RRDIS	Status outputs	RXRUNDISP[3:0]
T _{GCKDO} _RDAT	Data outputs	RXDATA[31:0]
Clock:		
T _{RX2PWH}	Clock pulse width, High state	RXUSRCLK2
T _{RX2PWH}	Clock pulse width, Low state	RXUSRCLK2

Table A-4: Parameters Relative to the TX User Clock2 (TXUSRCLK2)

Parameter	Function	Signals
Setup/Hold:		
T _{GCKC} _CFGEN/T _{GCKC} _CFGEN	Control inputs	CONFIGENABLE
T _{GCKC} _TBYP/T _{GCKC} _TBYP	Control inputs	TXBYPASS8B10B[3:0]
T _{GCKC} _TCRCE/T _{GCKC} _TCRCE	Control inputs	TXFORCECERCERR
T _{GCKC} _TPOL/T _{GCKC} _TPOL	Control inputs	TXPOLARITY
T _{GCKC} _TINH/T _{GCKC} _TINH	Control inputs	TXINHIBIT
T _{GCKC} _LBK/T _{GCKC} _LBK	Control inputs	LOOPBACK[1:0]

Table A-4: Parameters Relative to the TX User Clock2 (TXUSRCLK2) (Continued)

Parameter	Function	Signals
$T_{GCKK_TRST}/T_{GCKC_TRST}$	Control inputs	TXRESET
$T_{GCKK_TKCH}/T_{GCKC_TKCH}$	Control inputs	TXCHARISK[3:0]
$T_{GCKK_TCDM}/T_{GCKC_TCDM}$	Control inputs	TXCHARDISPMODE[3:0]
$T_{GCKK_TCDV}/T_{GCKC_TCDV}$	Control inputs	TXCHARDISPVAL[3:0]
$T_{GDCK_CFGIN}/T_{GCKD_CFGIN}$	Data inputs	CONFIGIN
$T_{GDCK_TDAT}/T_{GCKD_TDAT}$	Data inputs	TXDATA[31:0]
Clock to Out:		
T_{GCKST_TBERR}	Status outputs	TXBUFERR
T_{GCKST_TKERR}	Status outputs	TXKERR[3:0]
T_{GCKDO_TRDIS}	Data outputs	TXRUNDISP[3:0]
T_{GCKDO_CFGOUT}	Data outputs	CONFIGOUT
Clock:		
T_{TX2PWH}	Clock pulse width, High state	TXUSRCLK2
T_{TX2PWL}	Clock pulse width, Low state	TXUSRCLK2

Table A-5: Miscellaneous Clock Parameters

Parameter	Function	Signals
Clock:		
T_{REFPWH}	Clock pulse width, High state	REFCLK ⁽¹⁾
T_{REFPWL}	Clock pulse width, Low state	REFCLK ⁽¹⁾
$T_{BREFPWH}$	Clock pulse width, High state	BREFCLK ⁽²⁾
$T_{BREFPWL}$	Clock pulse width, Low state	BREFCLK ⁽²⁾
T_{TX2PWH}	Clock pulse width, High state	TXUSRCLK ⁽³⁾
T_{TX2PWL}	Clock pulse width, Low state	TXUSRCLK ⁽³⁾

Notes:

1. REFCLK is not synchronous to any RocketIO signals.
2. BREFCLK is not synchronous to any RocketIO signals.
3. TXUSRCLK is not synchronous to any RocketIO signals.

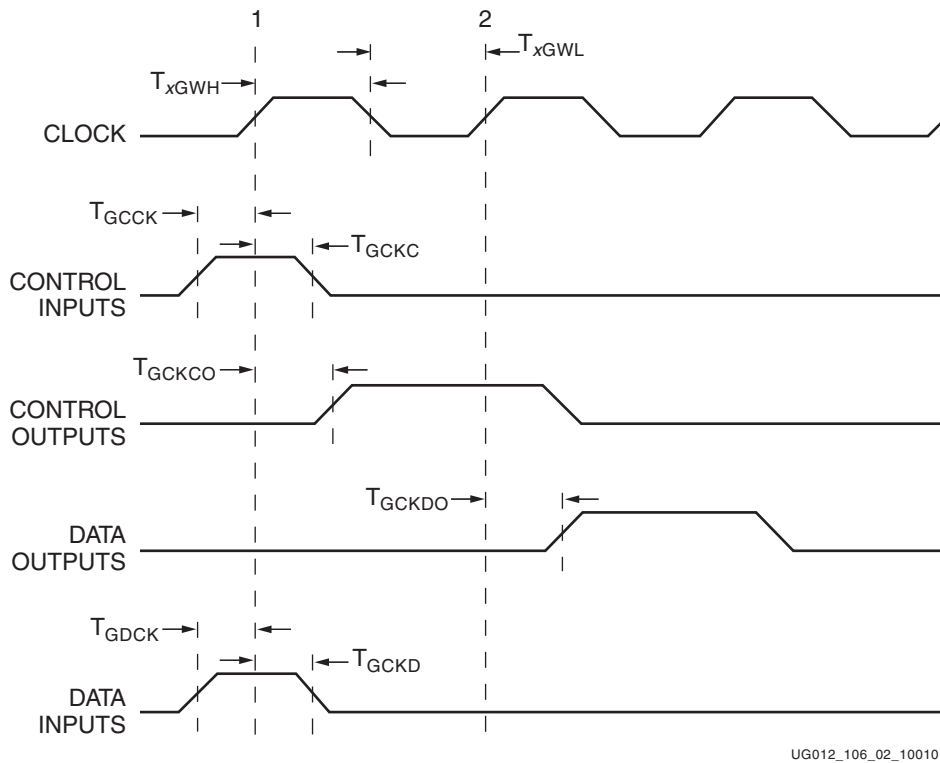

Figure A-2: RocketIO Transceiver Timing Relative to Clock Edge



8B/10B Valid Characters

8B/10B encoding includes a set of Data characters and K-characters. Eight-bit values are coded into 10-bit values keeping the serial line DC balanced. K-characters are special Data characters designated with a CHARISK. K-characters are used for specific informative designations. [Table B-1](#) and [Table B-2](#) show the Data and K tables of valid characters.

Valid Data Characters

Table B-1: Valid Data Characters

Data Byte Name	Bits HGF EDCBA	Current RD – abcdei fghj	Current RD + abcdei fghj
D0.0	000 00000	100111 0100	011000 1011
D1.0	000 00001	011101 0100	100010 1011
D2.0	000 00010	101101 0100	010010 1011
D3.0	000 00011	110001 1011	110001 0100
D4.0	000 00100	110101 0100	001010 1011
D5.0	000 00101	101001 1011	101001 0100
D6.0	000 00110	011001 1011	011001 0100
D7.0	000 00111	111000 1011	000111 0100
D8.0	000 01000	111001 0100	000110 1011
D9.0	000 01001	100101 1011	100101 0100
D10.0	000 01010	010101 1011	010101 0100
D11.0	000 01011	110100 1011	110100 0100
D12.0	000 01100	001101 1011	001101 0100
D13.0	000 01101	101100 1011	101100 0100
D14.0	000 01110	011100 1011	011100 0100
D15.0	000 01111	010111 0100	101000 1011
D16.0	000 10000	011011 0100	100100 1011
D17.0	000 10001	100011 1011	100011 0100
D18.0	000 10010	010011 1011	010011 0100

Table B-1: Valid Data Characters (Continued)

Data Byte Name	Bits HGF EDCBA	Current RD – abcdei fghj	Current RD + abcdei fghj
D19.0	000 10011	110010 1011	110010 0100
D20.0	000 10100	001011 1011	001011 0100
D21.0	000 10101	101010 1011	101010 0100
D22.0	000 10110	011010 1011	011010 0100
D23.0	000 10111	111010 0100	000101 1011
D24.0	000 11000	110011 0100	001100 1011
D25.0	000 11001	100110 1011	100110 0100
D26.0	000 11010	010110 1011	010110 0100
D27.0	000 11011	110110 0100	001001 1011
D28.0	000 11100	001110 1011	001110 0100
D29.0	000 11101	101110 0100	010001 1011
D30.0	000 11110	011110 0100	100001 1011
D31.0	000 11111	101011 0100	010100 1011
D0.1	001 00000	100111 1001	011000 1001
D1.1	001 00001	011101 1001	100010 1001
D2.1	001 00010	101101 1001	010010 1001
D3.1	001 00011	110001 1001	110001 1001
D4.1	001 00100	110101 1001	001010 1001
D5.1	001 00101	101001 1001	101001 1001
D6.1	001 00110	011001 1001	011001 1001
D7.1	001 00111	111000 1001	000111 1001
D8.1	001 01000	111001 1001	000110 1001
D9.1	001 01001	100101 1001	100101 1001
D10.1	001 01010	010101 1001	010101 1001
D11.1	001 01011	110100 1001	110100 1001
D12.1	001 01100	001101 1001	001101 1001
D13.1	001 01101	101100 1001	101100 1001
D14.1	001 01110	011100 1001	011100 1001
D15.1	001 01111	010111 1001	101000 1001
D16.1	001 10000	011011 1001	100100 1001
D17.1	001 10001	100011 1001	100011 1001

Product Not Recommended for New Designs

Table B-1: Valid Data Characters (Continued)

Data Byte Name	Bits HGF EDCBA	Current RD – abcdei fghj	Current RD + abcdei fghj
D18.1	001 10010	010011 1001	010011 1001
D19.1	001 10011	110010 1001	110010 1001
D20.1	001 10100	001011 1001	001011 1001
D21.1	001 10101	101010 1001	101010 1001
D22.1	001 10110	011010 1001	011010 1001
D23.1	001 10111	111010 1001	000101 1001
D24.1	001 11000	110011 1001	001100 1001
D25.1	001 11001	100110 1001	100110 1001
D26.1	001 11010	010110 1001	010110 1001
D27.1	001 11011	110110 1001	001001 1001
D28.1	001 11100	001110 1001	001110 1001
D29.1	001 11101	101110 1001	010001 1001
D30.1	001 11110	011110 1001	100001 1001
D31.1	001 11111	101011 1001	010100 1001
D0.2	010 00000	100111 0101	011000 0101
D1.2	010 00001	011101 0101	100010 0101
D2.2	010 00010	101101 0101	010010 0101
D3.2	010 00011	110001 0101	110001 0101
D4.2	010 00100	110101 0101	001010 0101
D5.2	010 00101	101001 0101	101001 0101
D6.2	010 00110	011001 0101	011001 0101
D7.2	010 00111	111000 0101	000111 0101
D8.2	010 01000	111001 0101	000110 0101
D9.2	010 01001	100101 0101	100101 0101
D10.2	010 01010	010101 0101	010101 0101
D11.2	010 01011	110100 0101	110100 0101
D12.2	010 01100	001101 0101	001101 0101
D13.2	010 01101	101100 0101	101100 0101
D14.2	010 01110	011100 0101	011100 0101
D15.2	010 01111	010111 0101	101000 0101
D16.2	010 10000	011011 0101	100100 0101

Table B-1: Valid Data Characters (Continued)

Data Byte Name	Bits HGF EDCBA	Current RD – abcdei fghj	Current RD + abcdei fghj
D17.2	010 10001	100011 0101	100011 0101
D18.2	010 10010	010011 0101	010011 0101
D19.2	010 10011	110010 0101	110010 0101
D20.2	010 10100	001011 0101	001011 0101
D21.2	010 10101	101010 0101	101010 0101
D22.2	010 10110	011010 0101	011010 0101
D23.2	010 10111	111010 0101	000101 0101
D24.2	010 11000	110011 0101	001100 0101
D25.2	010 11001	100110 0101	100110 0101
D26.2	010 11010	010110 0101	010110 0101
D27.2	010 11011	110110 0101	001001 0101
D28.2	010 11100	001110 0101	001110 0101
D29.2	010 11101	101110 0101	010001 0101
D30.2	010 11110	011110 0101	100001 0101
D31.2	010 11111	101011 0101	010100 0101
D0.3	011 00000	100111 0011	011000 1100
D1.3	011 00001	011101 0011	100010 1100
D2.3	011 00010	101101 0011	010010 1100
D3.3	011 00011	110001 1100	110001 0011
D4.3	011 00100	110101 0011	001010 1100
D5.3	011 00101	101001 1100	101001 0011
D6.3	011 00110	011001 1100	011001 0011
D7.3	011 00111	111000 1100	000111 0011
D8.3	011 01000	111001 0011	000110 1100
D9.3	011 01001	100101 1100	100101 0011
D10.3	011 01010	010101 1100	010101 0011
D11.3	011 01011	110100 1100	110100 0011
D12.3	011 01100	001101 1100	001101 0011
D13.3	011 01101	101100 1100	101100 0011
D14.3	011 01110	011100 1100	011100 0011
D15.3	011 01111	010111 0011	101000 1100

Product Not Recommended for New Designs

Table B-1: Valid Data Characters (Continued)

Data Byte Name	Bits HGF EDCBA	Current RD – abcdei fghj	Current RD + abcdei fghj
D16.3	011 10000	011011 0011	100100 1100
D17.3	011 10001	100011 1100	100011 0011
D18.3	011 10010	010011 1100	010011 0011
D19.3	011 10011	110010 1100	110010 0011
D20.3	011 10100	001011 1100	001011 0011
D21.3	011 10101	101010 1100	101010 0011
D22.3	011 10110	011010 1100	011010 0011
D23.3	011 10111	111010 0011	000101 1100
D24.3	011 11000	110011 0011	001100 1100
D25.3	011 11001	100110 1100	100110 0011
D26.3	011 11010	010110 1100	010110 0011
D27.3	011 11011	110110 0011	001001 1100
D28.3	011 11100	001110 1100	001110 0011
D29.3	011 11101	101110 0011	010001 1100
D30.3	011 11110	011110 0011	100001 1100
D31.3	011 11111	101011 0011	010100 1100
D0.4	100 00000	100111 0010	011000 1101
D1.4	100 00001	011101 0010	100010 1101
D2.4	100 00010	101101 0010	010010 1101
D3.4	100 00011	110001 1101	110001 0010
D4.4	100 00100	110101 0010	001010 1101
D5.4	100 00101	101001 1101	101001 0010
D6.4	100 00110	011001 1101	011001 0010
D7.4	100 00111	111000 1101	000111 0010
D8.4	100 01000	111001 0010	000110 1101
D9.4	100 01001	100101 1101	100101 0010
D10.4	100 01010	010101 1101	010101 0010
D11.4	100 01011	110100 1101	110100 0010
D12.4	100 01100	001101 1101	001101 0010
D13.4	100 01101	101100 1101	101100 0010
D14.4	100 01110	011100 1101	011100 0010
D15.4	100 01111	010111 0010	101000 1101
D16.4	100 10000	011011 0010	100100 1101

Table B-1: Valid Data Characters (Continued)

Data Byte Name	Bits HGF EDCBA	Current RD – abcdei fghj	Current RD + abcdei fghj
D17.4	100 10001	100011 1101	100011 0010
D18.4	100 10010	010011 1101	010011 0010
D19.4	100 10011	110010 1101	110010 0010
D20.4	100 10100	001011 1101	001011 0010
D21.4	100 10101	101010 1101	101010 0010
D22.4	100 10110	011010 1101	011010 0010
D23.4	100 10111	111010 0010	000101 1101
D24.4	100 11000	110011 0010	001100 1101
D25.4	100 11001	100110 1101	100110 0010
D26.4	100 11010	010110 1101	010110 0010
D27.4	100 11011	110110 0010	001001 1101
D28.4	100 11100	001110 1101	001110 0010
D29.4	100 11101	101110 0010	010001 1101
D30.4	100 11110	011110 0010	100001 1101
D31.4	100 11111	101011 0010	010100 1101
D0.5	101 00000	100111 1010	011000 1010
D1.5	101 00001	011101 1010	100010 1010
D2.5	101 00010	101101 1010	010010 1010
D3.5	101 00011	110001 1010	110001 1010
D4.5	101 00100	110101 1010	001010 1010
D5.5	101 00101	101001 1010	101001 1010
D6.5	101 00110	011001 1010	011001 1010
D7.5	101 00111	111000 1010	000111 1010
D8.5	101 01000	111001 1010	000110 1010
D9.5	101 01001	100101 1010	100101 1010
D10.5	101 01010	010101 1010	010101 1010
D11.5	101 01011	110100 1010	110100 1010
D12.5	101 01100	001101 1010	001101 1010
D13.5	101 01101	101100 1010	101100 1010
D14.5	101 01110	011100 1010	011100 1010
D15.5	101 01111	010111 1010	101000 1010
D16.5	101 10000	011011 1010	100100 1010
D17.5	101 10001	100011 1010	100011 1010

Product Not Recommended for New Designs

Table B-1: Valid Data Characters (Continued)

Data Byte Name	Bits HGF EDCBA	Current RD – abcdei fghj	Current RD + abcdei fghj
D18.5	101 10010	010011 1010	010011 1010
D19.5	101 10011	110010 1010	110010 1010
D20.5	101 10100	001011 1010	001011 1010
D21.5	101 10101	101010 1010	101010 1010
D22.5	101 10110	011010 1010	011010 1010
D23.5	101 10111	111010 1010	000101 1010
D24.5	101 11000	110011 1010	001100 1010
D25.5	101 11001	100110 1010	100110 1010
D26.5	101 11010	010110 1010	010110 1010
D27.5	101 11011	110110 1010	001001 1010
D28.5	101 11100	001110 1010	001110 1010
D29.5	101 11101	101110 1010	010001 1010
D30.5	101 11110	011110 1010	100001 1010
D31.5	101 11111	101011 1010	010100 1010
D0.6	110 00000	100111 0110	011000 0110
D1.6	110 00001	011101 0110	100010 0110
D2.6	110 00010	101101 0110	010010 0110
D3.6	110 00011	110001 0110	110001 0110
D4.6	110 00100	110101 0110	001010 0110
D5.6	110 00101	101001 0110	101001 0110
D6.6	110 00110	011001 0110	011001 0110
D7.6	110 00111	111000 0110	000111 0110
D8.6	110 01000	111001 0110	000110 0110
D9.6	110 01001	100101 0110	100101 0110
D10.6	110 01010	010101 0110	010101 0110
D11.6	110 01011	110100 0110	110100 0110
D12.6	110 01100	001101 0110	001101 0110
D13.6	110 01101	101100 0110	101100 0110
D14.6	110 01110	011100 0110	011100 0110
D15.6	110 01111	010111 0110	101000 0110
D16.6	110 10000	011011 0110	100100 0110
D17.6	110 10001	100011 0110	100011 0110
D18.6	110 10010	010011 0110	010011 0110

Table B-1: Valid Data Characters (Continued)

Data Byte Name	Bits HGF EDCBA	Current RD – abcdei fghj	Current RD + abcdei fghj
D19.6	110 10011	110010 0110	110010 0110
D20.6	110 10100	001011 0110	001011 0110
D21.6	110 10101	101010 0110	101010 0110
D22.6	110 10110	011010 0110	011010 0110
D23.6	110 10111	111010 0110	000101 0110
D24.6	110 11000	110011 0110	001100 0110
D25.6	110 11001	100110 0110	100110 0110
D26.6	110 11010	010110 0110	010110 0110
D27.6	110 11011	110110 0110	001001 0110
D28.6	110 11100	001110 0110	001110 0110
D29.6	110 11101	101110 0110	010001 0110
D30.6	110 11110	011110 0110	100001 0110
D31.6	110 11111	101011 0110	010100 0110
D0.7	111 00000	100111 0001	011000 1110
D1.7	111 00001	011101 0001	100010 1110
D2.7	111 00010	101101 0001	010010 1110
D3.7	111 00011	110001 1110	110001 0001
D4.7	111 00100	110101 0001	001010 1110
D5.7	111 00101	101001 1110	101001 0001
D6.7	111 00110	011001 1110	011001 0001
D7.7	111 00111	111000 1110	000111 0001
D8.7	111 01000	111001 0001	000110 1110
D9.7	111 01001	100101 1110	100101 0001
D10.7	111 01010	010101 1110	010101 0001
D11.7	111 01011	110100 1110	110100 1000
D12.7	111 01100	001101 1110	001101 0001
D13.7	111 01101	101100 1110	101100 1000
D14.7	111 01110	011100 1110	011100 1000
D15.7	111 01111	010111 0001	101000 1110
D16.7	111 10000	011011 0001	100100 1110
D17.7	111 10001	100011 0111	100011 0001
D18.7	111 10010	010011 0111	010011 0001
D19.7	111 10011	110010 1110	110010 0001

Product Not Recommended for New Designs

Table B-1: Valid Data Characters (Continued)

Data Byte Name	Bits HGF EDCBA	Current RD – abcdei fghj	Current RD + abcdei fghj
D20.7	111 10100	001011 0111	001011 0001
D21.7	111 10101	101010 1110	101010 0001
D22.7	111 10110	011010 1110	011010 0001
D23.7	111 10111	111010 0001	000101 1110
D24.7	111 11000	110011 0001	001100 1110
D25.7	111 11001	100110 1110	100110 0001
D26.7	111 11010	010110 1110	010110 0001
D27.7	111 11011	110110 0001	001001 1110
D28.7	111 11100	001110 1110	001110 0001
D29.7	111 11101	101110 0001	010001 1110
D30.7	111 11110	011110 0001	100001 1110
D31.7	111 11111	101011 0001	010100 1110

Valid Control Characters (K-Characters)

Table B-2: Valid Control Characters (K-Characters)

Special Code Name	Bits HGF EDCBA	Current RD – abcdei fghj	Current RD + abcdei fghj
K28.0	000 11100	001111 0100	110000 1011
K28.1	001 11100	001111 1001	110000 0110
K28.2	010 11100	001111 0101	110000 1010
K28.3	011 11100	001111 0011	110000 1100
K28.4	100 11100	001111 0010	110000 1101
K28.5	101 11100	001111 1010	110000 0101
K28.6	110 11100	001111 0110	110000 1001
K28.7 ⁽¹⁾	111 11100	001111 1000	110000 0111
K23.7	111 10111	111010 1000	000101 0111
K27.7	111 11011	110110 1000	001001 0111
K29.7	111 11101	101110 1000	010001 0111
K30.7	111 11110	011110 1000	100001 0111

Notes:

1. Used for testing and characterization only. Do not use in protocols.



Related Online Documents

The documents described in this Appendix are accessible on the Xilinx website at www.xilinx.com. Document links shown in blue are clickable in this PDF file, providing easy access to the most current revision of each document.

Application Notes

XAPP572: A 3/4/5/6X Oversampling Circuit for 200 Mb/s to 1000 Mb/s Serial Interfaces

High-speed Serializer/Deserializer (SERDES) devices (1 Gb/s and higher) are often analog-based and tuned for a particular frequency range. If a design requires using the SERDES for lower-rate applications, such as interfacing with legacy systems, an oversampling circuit must be attached to the "back end" of the SERDES to extend the SERDES to the lower frequency ranges. The circuit works by oversampling the incoming serial data stream, evaluating data transition locations, and extracting valid data bits from the oversampled data.

The oversampling module described in this application note performs 3/4/5/6X oversampling. The oversampling ratio is selectable during operation to facilitate multi-rate applications. It is designed to accept 20 bits of oversampled data and to output 10 bits of extracted data to the user interface. This module can be used with the Virtex-II Pro™ RocketIO™ Multi-Gigabit Transceiver (MGT) to achieve line rates of 200 Mb/s to 1000 Mb/s. When using the Virtex-II Pro RocketIO MGT, sinusoidal input jitter tolerance exceeds 0.55 UI(1) for 3/4/5X oversampling when tested with the PRBS-23 data pattern, and over 0.38 UI(2) when tested with the SONET CID data pattern.

Characterization reports and descriptions of the oversampling techniques are available in the Xilinx SPICE Lounge (<http://support.xilinx.com/support/software/spice/spice-request.htm>) in a document titled, *RocketIO 3X-Oversampling Logic Block Characterization: Test Report*.

For applications requiring line rates less than 200 Mb/s, using Virtex-II Pro X 10 Gb/s RocketIO X MGTs, or implementing SD-SDI functionality, contact the Xilinx support hotline for oversampling circuits that are specially designed and optimized for each of these applications.

XAPP648: Serial Backplane Interface to a Shared Memory

This application note utilizes the Virtex-II Pro™ RocketIO™ transceivers and the Xilinx Aurora Protocol Engine to provide a multi-ported interface to a shared memory system in a backplane environment. Multiprocessor systems are often encountered in backplane systems, and distributed processing applications require access to a shared memory across

a backplane bus. Utilization of a hardware test-and-set lock mechanism, along with a software protocol to test for a semaphore grant prior to accessing the shared memory, guarantees atomic access to the shared memory.

XAPP649: SONET Rate Conversion in Virtex-II Pro Devices

The RocketIO transceivers have several modes of operation, but all modes rely on the internal transmitter clock being multiplied by 20 for data transmission. For example, a 20-bit data stream passed to the unit at 125 MHz is serialized and retransmitted at 2.5 Gb/s. At a 156.25 MHz input, the output is at its maximum speed of 3.125 Gb/s. The parallel data stream applied to the RocketIO transceiver can either be 20 bits direct, or it can be written as 16 bits, to which 8b/10b coding is applied to generate the 20 bits required.

However, there is a class of applications, typically in SONET processing systems, where the data path is 16 bits wide, running at 155.52 MHz. The designer would ideally apply the data directly to the RocketIO transceiver for onward transmission at $155.52 \times 16 = 2.48832$ Gb/s. Since this cannot be done in Virtex-II Pro devices, this application note describes the logic necessary to perform this function.

This application note is divided into two sections, the first is the logic necessary for the data width conversion, and the second describes the clocking characteristics required by the RocketIO transceiver.

XAPP651: SONET and OTN Scramblers/Descramblers

Both SONET and OTN are standards for data transmission over fibre optic links. This implies a need for clock recovery at the receiver, which in turn requires a guaranteed minimum number of transitions in the incoming serial data stream. The mechanism to achieve this transition density, similar for both SONET and OTN, is known as scrambling. The scrambling (and descrambling) function is independent of the serial data rate used. Serial data for transmission is added to the output of a pseudo-random number generator, running at the same clock frequency. The same circuit is used in the receiver to recover the original data transmitted. Obviously, the pseudo-random number generators at each end of the link must be in phase. This is achieved using a known pattern of framing information (which is actually transmitted unscrambled). This is covered in more detail in XAPP652.

XAPP652: Word Alignment and SONET/SDH Deframing

This application note describes the logic to perform basic word alignment and deframing specifically for SONET/SDH systems, where data is being processed at 16 bits or 64 bits per clock cycle.

XAPP660: Partial Reconfiguration of RocketIO Pre-emphasis and Differential Swing Control Attributes

This application note describes a pre-engineered solution for Virtex-II Pro devices using the IBM PowerPC™ 405 core to perform a partial reconfiguration of the RocketIO™ multi-gigabit transceivers (MGTs) pre-emphasis and differential swing control attributes. This solution is ideal for applications where these attributes must be modified to optimize the MGT signal transmission for various system environments while leaving the rest of the FPGA design unchanged. The hardware and software elements of this solution can be easily integrated into any Virtex-II Pro design. The associated reference design supports the following devices: XC2VP4, XC2VP7, XC2VP20, and XC2VP50. The design discussed

in this document uses the PPC405 core device control register (DCR) bus interface to implement a simple solution with a minimum of FPGA resources.

XAPP661: RocketIO Transceiver Bit-Error Rate Tester

This application note describes the implementation of a RocketIO transceiver bit-error rate tester (BERT) reference design demonstrating a serial link (1.0 Gb/s to 3.125 Gb/s) between two RocketIO multi-gigabit transceivers (MGT) embedded in a single Virtex-II Pro FPGA. To build a system, an IBM CoreConnect™ infrastructure connects the PowerPC™405 processor (PPC405) to external memory and other peripherals using the processor local bus (PLB) and device control register (DCR) buses. The reference design uses a two-channel Xilinx bit-error rate tester (XBERT) module for generating and verifying high-speed serial data transmitted and received by the RocketIO transceivers. The data to be transmitted is constructed using pseudorandom bit sequence (PRBS) patterns. The receiver in XBERT module compares the incoming data with the expected data to analyze for errors. The XBERT supports several different types of user selectable PRBS patterns. Frame counters in the receiver are used to track the total number of data words (frames) received, and total number of data words with bit errors. The processor reads the status and counter values from the XBERT through the PLB Interface, then sends out the information to the UART.

XAPP662: In-Circuit Partial Reconfiguration of RocketIO Attributes

This application note describes in-circuit partial reconfiguration of RocketIO transceiver attributes using the Virtex-II Pro internal configuration access port (ICAP). The solution uses a Virtex-II Pro device with an IBM PowerPC™ 405 (PPC405) processor to perform a partial reconfiguration of the RocketIO multi-gigabit transceivers (MGTs) pre-emphasis and differential swing control attributes. These attributes must be modified to optimize the MGT signal transmission prior to and after a system has been deployed in the field. This solution is also ideal for characterization, calibration, and system testing.

The hardware and software elements of this solution can be easily integrated into any Virtex-II Pro design already utilizing the PLB or OPB bus structures. The reference design uses a Xilinx intellectual property interface (IPIF) connecting to either the PLB or OPB buses. This design also provides for a terminal interface using a serial port connection, allowing MGT attribute settings to be changed through command line entries. Design modules are also included to facilitate bit-error rate tests (BERT) and pseudo-random binary sequence (PRBS) diagnostics.

XAPP669: PPC405 PPE Reference System Using Virtex-II Pro RocketIO Transceivers

The PPC405 Packet Processing Engine (PPE) Reference System using Virtex-II Pro™ RocketIO™ transceivers addresses the need in the digital communications market for high speed data transfer. Serial protocols can be controlled by complex logic, but are more simply handled by a microprocessor—in this case, the IBM® PowerPC® 405 (PPC405) processors embedded in the Virtex-II Pro™ FPGA. This reference system is an example of a high-speed serial-link packet processing engine implemented in Virtex-II Pro FPGAs. The Embedded Development Kit (EDK) is used exclusively in the design and implementation of both hardware and software in this reference system. This reference design has been verified on the Memec Design Virtex-II Pro P4 Development Board. Instructions are included to allow the reader to reproduce the design on this board.

XAPP670: Minimizing Receiver Elastic Buffer Delay in the Virtex-II Pro RocketIO Transceiver

This application note describes a design that reduces latency through the receive elastic buffer of the Virtex-II Pro™ RocketIO™ transceiver. This note is only applicable for designs that do not use the clock correction or channel bonding features of the RocketIO transceiver. (These operations can still be done in the fabric, if needed).

XAPP680: HD-SDI Transmitter Using Virtex-II Pro RocketIO Multi-Gigabit Transceivers

The High-Definition Serial Digital Interface (HD-SDI) standard describes how to transport high definition (HD) digital video serially over video coax cable. HD-SDI is used to connect HD video equipment in broadcast studios and video production centers. It is an evolution of the popular SDI standard that is widely used to transport standard-definition (SD) digital video in the broadcast industry.

The flexibility of RocketIO™ multi-gigabit transceivers available in the Virtex-II Pro™ family devices combined with the programmable logic of Virtex-II Pro FPGAs makes it possible to implement HD-SDI interfaces. Because every Virtex-II Pro FPGA has multiple RocketIO transceivers, it is possible to integrate multiple HD-SDI interfaces into one Virtex-II Pro device along with other video processing functions.

This application note describes the electrical specifications for HD-SDI transmitters and the HD-SDI data format. It also presents several implementation examples and reference designs for an HD-SDI transmitter implemented using the Virtex-II Pro FPGA.

XAPP681: HD-SDI Receiver Using Virtex-II Pro RocketIO Multi-Gigabit Transceivers

The High-Definition Serial Digital Interface (HD-SDI) standard describes how to transport high definition (HD) digital video serially over video coax cable. HD-SDI is used to connect HD video equipment in broadcast studios and video production centers. It is an evolution of the popular SDI standard that is widely used to transport standard-definition (SD) digital video in the broadcast industry.

The flexibility of the RocketIO™ multi-gigabit transceivers available in the Virtex-II Pro™ family devices combined with the programmable logic of the Virtex-II Pro FPGAs makes it possible to implement HD-SDI interfaces. Because every Virtex-II Pro FPGA has multiple RocketIO transceivers, multiple HD-SDI interfaces can be integrated into one Virtex-II Pro device along with other video processing functions.

This application note describes how to implement HD-SDI receivers. An HD-SDI receiver built in a Virtex-II Pro FPGA is presented as a reference design.

XAPP683: Multi-Rate HD/SD-SDI Transmitter Using Virtex-II Pro RocketIO Multi-Gigabit Transceivers

The SD-SDI standard is widely used in broadcast studios and video production centers to transport standard definition (SD) digital video serially over video coax cable. The HD-SDI standard is similar, but transports high-definition (HD) digital video. The SD-SDI and HD-SDI standards are similar enough that it is possible to implement interfaces for video equipment that support both standards through the same connector.

This application note describes how to use the RocketIO multi-gigabit transceivers available in the Virtex-II Pro family of FPGA devices to implement a transmitter that can support both SD-SDI and HD-SDI. The flexibility of the RocketIO transceivers combined with the programmable logic of the Virtex-II Pro devices makes it possible to implement multi-rate SDI interfaces.

Since all Virtex-II Pro devices have four or more RocketIO transceivers, it is possible to implement multiple HD-SDI and SDI-SDI interfaces in a single FPGA.

XAPP684: Multi-Rate HD/SD-SDI Receiver Using Virtex-II Pro RocketIO Multi-Gigabit Transceivers

The SD-SDI standard is widely used in broadcast studios and video production centers to transport standard definition (SD) digital video serially over video coax cable. The HD-SDI standard is similar, but transports high-definition (HD) digital video. The SD-SDI and HD-SDI standards are similar enough that it is possible to implement interfaces for video equipment that support both standards through the same connector.

This application note describes how to use the RocketIO multi-gigabit transceivers available in the Virtex-II Pro family of FPGA devices to implement a receiver that can support both SD-SDI and HD-SDI. The flexibility of the RocketIO transceivers combined with the programmable logic of the Virtex-II Pro devices makes it possible to implement multi-rate SDI interfaces.

XAPP687: 64B/66B Encoder/Decoder

This application note describes the encoding and decoding blocks of the 64B/66B encoding scheme. This application allows designs to use the RocketIO™ transceiver of the Virtex-II Pro™ device or an external SerDes with either Virtex-II™ or Virtex-II Pro devices.

XAPP756: Transmitting DDR Data Between LVDS and RocketIO CML Devices

The serial transfer of data between devices on a board or cards on a backplane using the LVDS differential standard is well established. Existing cards need to be able to interface to newer technologies. This application note discusses two possible ways to interconnect standard LVDS transceivers with the Current Mode Logic (CML) technology used in Xilinx RocketIO™ multi-gigabit transceivers (MGTs) through AC coupling and DC coupling.

XAPP763: Local Clocking for MGT RXRECCLK in Virtex-II Pro Devices

This application note describes the local clocking resources available in the Virtex-II Pro architecture for the RXRECCLK of the 3.125 Gb/s RocketIO™ multi-gigabit transceivers (MGTs). Using RXRECCLK with local clock routing can enable applications to bypass the MGT's elastic buffer, thus reducing latency without consuming global clock resources. Along with a reference design, this application note explains how to use the local clocking resources.

Characterization Reports

Characterization Reports can be accessed from:

http://www.xilinx.com/xlnx/xweb/xil_publications_index.jsp?category=Reports.

SPICE models can be accessed from the Xilinx Download Center at:

http://www.xilinx.com/xlnx/xil_sw_updates_home.jsp.

Select **HSPICE and Eldo Models** and then **Virtex-II Pro** from the pull-down menus.

Online registration is required. Follow the instructions on the web page to register.

Virtex-II Pro RocketIO Multi-Gigabit Transceiver Characterization Summary

Virtex-II Pro devices contain up to twenty-four embedded RocketIO multi-gigabit transceivers (MGTs) for the creation of high-speed serial links from chip to chip, across a backplane, or from system to system. Each MGT has separate transmit and receive functions (full-duplex) and can be operated at baud rates from 600 Mb/s to 3.125 Gb/s. Additionally, every RocketIO MGT block is fully independent and contains a complete set of common SerDes (serializer/deserializer) functions. This allows Virtex-II Pro devices to support many existing and emerging serial I/O standards at data rates up to 10 Gb/s, including:

- XAUI (10 Gigabit Attachment Unit Interface)
- PCI Express™
- Serial RapidIO™
- Fibre Channel™
- Gigabit Ethernet
- Aurora (Xilinx proprietary link-layer protocol)

This document presents characterization data taken on Virtex-II Pro devices to verify the performance of the MGTs with respect to these standards and the product specification.

Virtex-II Pro RocketIO MGT HSSDC2 Cable Characterization

RocketIO multi-gigabit transceivers (MGTs) in Virtex-II Pro Platform FPGAs are capable of sending serial data at rates from 600 Mb/s to 3.125 Gb/s. Many links taking advantage of this technology involve some length of cable through which these signals travel. At these speeds, cable has the effect of degrading the quality of the signals, both distorting the waveforms and reducing their amplitude. This report illustrates the effects that an industry-standard cable, the HSSDC2, has on waveforms transmitted from a Virtex-II Pro device.

White Papers

WP157: Usage Models for Multi-Gigabit Serial Transceivers

This document provides an overview of the various usage models for high-speed, point-to-point, serial transceiver technology. While not intending to represent all the applications of this technology, it provides a basic categorization and description of some of the most common uses.

WP160: Emulating External SERDES Devices with Embedded RocketIO Transceivers

The Virtex-II Pro Platform FPGA provides an attractive single-chip solution to serial transceiver design problems that previously required multiple devices. This white paper describes several different dedicated external SERDES devices, and presents alternative design solutions using the Virtex-II Pro Platform FPGA with RocketIO transceivers. The four external devices discussed here are the Vitesse™ single-channel VSC7123, the Vitesse quadchannel VSC7216-01, the Texas Instruments™ TLK3101, and the Mindspeed™ CX27201. The features offered by each of these devices are presented, along with a discussion of how the RocketIO transceiver can afford an alternative to each multi-chip solution. Links to Xilinx information resources for the Virtex-II Pro Platform FPGA and embedded RocketIO transceiver are presented in the final section.

Index

Numerics

- 8B/10B Encoding/Decoding
 - bypassing 66
 - decoder 60
 - encoder 60
 - overview 60
 - ports and attributes 61
 - serial output format 66
- 8B/10B Valid Characters 135

A

- AC and DC Coupling 117
- Attributes & Ports (by function)
 - 8B/10B encoding/decoding 61
 - buffers, fabric interface 90
 - channel bonding 81
 - clock correction 73
 - CRC 85
 - SERDES alignment 67
 - synchronization logic 76
- Attributes (defined)
 - ALIGN_COMMA_MSB 67
 - CHAN_BOND_SEQ_LEN 81
 - CHAN_BOND_LIMIT 82
 - CHAN_BOND_MODE 81
 - CHAN_BOND_OFFSET 82
 - CHAN_BOND_ONE_SHOT 81
 - CHAN_BOND_SEQ_*_* 81
 - CHAN_BOND_SEQ_2_USE 81
 - CHAN_BOND_WAIT 82
 - CLK_COR_INSERT_IDLE_FLAG 75
 - CLK_COR_KEEP_IDLE 75
 - CLK_COR_REPEAT_WAIT 75
 - CLK_COR_SEQ_*_* 74
 - CLK_COR_SEQ_LEN 75
 - CLK_CORRECT_USE 73
 - COMMA_10B_MASK 70
 - CRC_END_OF_PACKET 88
 - CRC_FORMAT 85
 - CRC_START_OF_PACKET 88
 - DEC_MCOMMA_DETECT 70
 - DEC_PCOMMA_DETECT 70
 - DEC_VALID_COMMA_ONLY 70
 - MCOMMA_10B_VALUE 70
 - MCOMMA_DETECT 70

- PCOMMA_10B_VALUE 70
- PCOMMA_DETECT 70
- PRE_EMPHASIS 91
- RX_BUFFER_USE 74, 90
- RX_CRC_USE 85
- RX_DATA_WIDTH 90
- RX_DECODE_USE 61
- RX_LOS_INVALID_INCR 77
- RX_LOS_THRESHOLD 77
- RX_LOSS_OF_SYNC_FSM 77
- SERDES_10B 90
- TERMINATION_IMP 91
- TX_BUFFER_USE 90
- TX_CRC_FORCE_VALUE 89
- TX_CRC_USE 85
- TX_DATA_WIDTH 90
- TX_DIFF_CTRL 91
- Attributes (table) 29

B

- BREFCLK
 - and REF_CLK_V_SEL 32, 41
 - and REFCLKSEL 25, 41
 - and serial speed 39
 - pin numbers 41
 - when & how to use 41
- Buffers, Fabric Interface 89
 - ports and attributes 90
 - transmitter and elastic (receiver) 89
- Byte Mapping 38

C

- Channel Bonding (Alignment) 79
 - operation 80
 - ports and attributes 81
 - troubleshooting 83
 - Vitesse channel bonding sequence
 - receive 65
 - transmit 64
- Characters, valid (tables) 135
- Clock Correction (Recovery)
 - clock recovery 72
 - overview 71
 - ports and attributes 73
- Clock/Data Recovery (CDR) parameters 108

- Clocking 39
 - clock and data recovery 72
 - clock correction (recovery) 71
 - clock dependency 56
 - clock descriptions 127
 - clock pulse width 130
 - clock ratio 42
 - clock recovery 72
 - clock signals 39
 - clock synthesizer 71
 - clock-to-output delays 129
 - code examples
 - 1-byte clock 50
 - 2-byte clock 43
 - 4-byte clock 46
 - half-rate clocking scheme 54
 - multiplexed clocking scheme
 - with DCM 55
 - without DCM 55
- Control Characters, valid (table) 143
- Coupling, AC and DC 117
- CRC (Cyclic Redundancy Check) 84
 - generation 84
 - latency 85
 - operation 84
 - ports and attributes 85
 - support limitations 89

D

- Data Characters, valid (table) 135
- Data Path Latency 57
- Deserializer 67
- Deterministic Jitter (DJ) 108
- Differential Receiver 107
- Differential Trace Design 116

H

- Half-Rate Clocking Scheme 54
- HDL Code Examples
 - Verilog
 - 1-byte clock 52
 - 2-byte clock 45
 - 32-bit alignment design 95
 - 4-byte clock 49
 - VHDL
 - 1-byte clock 50

2-byte clock 43
 32-bit alignment design 98
 4-byte clock 47
 High-Speed Serial Trace Design 115
 HSPICE 121

I

Implementation Tools 121

J

Jitter
 and BREFCLK 41
 and use of DCM with REFCLK 39
 deterministic and random, defined 107
 parameters 107, 108
 PCB trace length mismatch 115

K

K-Characters, valid (table) 143

L

Latency, Data Path 57

M

Miscellaneous Signals 90
 Modifiable Primitives (table) 34
 Multiplexed Clocking Scheme
 with DCM 55
 without DCM 55

P

Package Pins 123
 Par 121
 Passive Filtering 111
 PCB Design Requirements 109
 Ports & Attributes (by function)
 8B/10B encoding/decoding 61
 buffers, fabric interface 90
 channel bonding 81
 clock correction 73
 CRC 85
 SERDES alignment 67
 synchronization logic 76
 Ports (defined)

CHBONDDONE 83
 CHBONDI 83
 CHBONDO 83
 ENCHANSYNC 81
 ENMCOMMAALIGN 68
 ENPCOMMAALIGN 68
 LOOPBACK 91
 POWERDOWN 120
 RXBUFSTATUS 90
 RXCHARISCOMMA 71
 RXCHARISK 63
 RXCHECKINGCRC 88
 RXCLKCORCNT 76, 83
 RXCOMMADET 71
 RXCRCERR 88
 RXDISPERR 64
 RXLOSSOFSYNC 77, 83
 RXNOTINTABLE 64
 RXPOLARITY 91
 RXREALIGN 70
 RXRECCLK 56
 RXRUNDISP 63
 TXBUFERR 90
 TXBYPASS8B10B 61
 TXCHARDISPMODE 62
 TXCHARDISPVAL 62
 TXCHARISK 63
 TXFORCECERCERR 89
 TXINHIBIT 91
 TXKERR 63
 TXPOLARITY 91
 TXRUNDISP 63

Ports (table) 24

Power Supply

passive filtering 111
 power conditioning 109

Power Supply Circuit Using Approved Regulator (figure) 110

Pre-emphasis

available values 104
 overview 104
 scope screen captures 105, 106

Q

Qualified Linear Regulators (table) 110

R

Random Jitter (RJ) 108
 Receive Data Path 32-bit Alignment 93
 Receiver Buffer 89

Reference Clock

generating 119
 oscillator (Epson), for LVPECL 119
 oscillator (Pletronics), for LVDS 119

Reset/Power Down 57

RocketIO transceiver

additional resources 18
 analog design considerations 103
 application notes 145
 attributes (table) 29
 basic architecture and capabilities 21
 block diagram 22, 128
 channel bonding (channel alignment) 79
 characterization reports 149
 clocking 39
 communications standards supported 21
 CRC (Cyclic Redundancy Check) 84
 default attribute values (tables) 34
 design notes
 analog 120
 digital 93
 digital design considerations 39
 modifiable primitives 34
 number of MGTs per device type 21
 PCB design requirements 109
 ports (table) 24
 powering 120
 related online documents 145
 reset/power down 57
 simulation and implementation 121
 unused transceivers 120
 valid control characters (K-characters) 143
 valid data characters 135
 white papers 151

Routing Serial Traces 115

S

SERDES Alignment

overview 67
 ports and attributes 67

Serial I/O Description 103

Serializer 67

Setup/Hold Times of Inputs Relative to Clock 129

Simulation Models 121

SmartModels 121

Synchronization Logic

overview 76
 ports and attributes 76

T

Termination Voltage 110
Timing Parameters 129
Total Jitter (DJ + RJ) 107
Transmitter and Elastic (Receiver) Buffers
89
Transmitter Buffer (FIFO) 89

U

User Guide conventions
online references 20
port and attribute names 19
typographical 19

V

Vitesse Disparity Example 64
Voltage Regulator Selection and Use 109

